

Rendex[®]

EXTERNAL CLADDING SYSTEM

PWS 
Prestige Wall Systems

TECHNICAL MANUAL

NCC 2022(Amdt.2) BCA Compliant



CODEMARK[®]
Australia

Certificate CM40090

Version 3.2026





PREFACE	4
1. PRODUCT ACCREDITATION	5
2. ABOUT THE RENDEX® PANEL	6
3. STRUCTURAL PERFORMANCE	8
4. FIRE AND THERMAL PERFORMANCE	9
5. SPECIFICATION	10
DESIGN PROCESS	10
MANUFACTURE AND SUPPLY	11
CONSTRUCTION	11
6. INSTALLATION OF RENDEX® EXTERNAL CLADDING SYSTEM	12
COMMENCEMENT	12
QUALIFICATIONS AND EXPERIENCE OF INSTALLERS	12
METHODOLOGY	12
FIXING REQUIREMENTS-FACTORY COATED PANELS	14
FIXING REQUIREMENTS-APPLICATOR COATED	14
INSPECTION AND TESTING REQUIREMENTS	15
7. MATERIALS	16
DAMP-PROOF COURSE	16
RENDEX® STARTER PANEL / STARTER TRIM	16
BREATHABLE WALL WRAP	16
BATTENS FOR CAVITY SYSTEMS	17
RENDEX® PANEL (EPS) PROPERTIES	17
EXPANDING FOAM FOR JOINTS	17
SCREW FIXINGS	18
WASHERS	18
MESHED EXTERNAL BEADING	18
FIBREGLASS MESH	19
RENDERING	20
8. INSTALLATION DETAILS SYSTEM 1	21
FIXING LOCATIONS	22
STEP BY STEP	23
GENERAL ARRANGEMENT SYSTEM 1	24
EAVE DETAIL OPTION A SYSTEM 1	25
EAVE DETAIL OPTION B SYSTEM 1	25
LOWER ROOF JUNCTION DETAIL SYSTEM 1	26
OVERHANG DRIP DETAIL SYSTEM 1	26
WINDOW DETAIL SYSTEM 1	27
CONCRETE REBATE DETAIL SYSTEM 1	27
RENDEX AND BRICK VENEER DETAIL SYSTEM 1	27
DISSIMILAR SUBSTRATES SYSTEM 1	28
VERTICAL MOVEMENT JOINT DETAIL SYSTEM 1	28
INTERNAL AND EXTERNAL CORNER DETAILS SYSTEM 1	29
GROUND SLAB DETAIL SYSTEM 1	30
DOWNPIPE FIXING DETAIL SYSTEM 1	31
	31

PARAPET AND BALUSTRADE WITH SADDLE FLASHIN SYSTEM 1	32
PENETRATION DETAIL AND PARAPET FLASHINGS SYSTEM 1	32
9. INSTALLATION DETAILS SYSTEM 2	33
FIXING LOCATIONS	34
STEP BY STEP	35
GENERAL ARRANGEMENT SYSTEM 2	36
EAVE DETAIL OPTION A SYSTEM 2	37
EAVE DETAIL OPTION B SYSTEM 2	37
LOWER ROOF JUNCTION DETAIL SYSTEM 2	38
OVERHANG DRIP DETAIL SYSTEM 2	38
WINDOW DETAIL SYSTEM 2	39
CONCRETE REBATE DETAIL SYSTEM 2	39
RENDEX® AND BRICK VENEER DETAIL SYSTEM 2	40
DISSIMILAR SUBSTRATES SYSTEM 2	40
VERTICAL MOVEMENT JOINT DETAIL SYSTEM 2	41
INTERNAL AND EXTERNAL CORNER DETAILS SYSTEM 2	42
GROUND SLAB DETAIL SYSTEM 2	43
DOWNPIPE FIXING DETAIL SYSTEM 2	43
PENETRATION DETAIL SYSTEM 2	44
PARAPET AND BALUSTRADING WITH SADDLE FLASHING SYSTEM 2	44
10. INSTALLATION DETAILS SYSTEM 3	45
FIXING LOCATIONS	46
STEP BY STEP	47
GENERAL ARRANGEMENT SYSTEM 3	48
EAVE DETAIL OPTION A SYSTEM 3	49
EAVE DETAIL OPTION B SYSTEM 3	49
LOWER ROOF JUNCTION DETAIL SYSTEM 3	50
WINDOW DETAIL SYSTEM 3	50
CONCRETE REBATE DETAIL SYSTEM 3	51
OVERHANG DRIP DETAIL DETAIL SYSTEM 3	51
RENDEX® AND BRICK VENEER DETAIL SYSTEM 3	52
DISSIMILAR SUBSTRATES SYSTEM 3	52
VERTICAL MOVEMENT JOINT DETAIL SYSTEM 3	52
INTERNAL AND EXTERNAL CORNER DETAILS SYSTEM 3	53
GROUND SLAB DETAIL SYSTEM 3	54
DOWNPIPE FIXING DETAIL SYSTEM 3	54
PARAPET AND BALUSTRADING WITH SADDLE FLASHING SYSTEM 3	55
PENETRATION DETAIL SYSTEM 3	55
11. COMMON DETAILS	56
MESHING OF RENDEX PANELS AT WINDOW OPENINGS SYSTEMS 1, 2 AND 3	56
PARAPET AND BOX GUTTER DETAIL SYSTEMS 1, 2 AND 3	56
12. CERTIFICATION OF PERFORMANCE SOLUTION	57
13. WARRANTY	58

RendeX® EXTERNAL CLADDING SYSTEM

The RendeX® External Cladding System, manufactured and supplied by Prestige Wall Systems Pty Ltd (PWS) is a multi-layered, BCA Compliant exterior wall cladding system. The benefits are superior energy efficiency, weather resistance, design flexibility, lightweight construction, quick and easy installation, strong and durable structure, yet with the appearance of a rendered brick wall. The RendeX® External Cladding System is an insulating, decorative and protective finish system for exterior walls that can be used in many different types of construction. The RendeX® External Cladding System is a cost effective solution for Domestic, plus some limited Commercial and Industrial applications.

The key element of the RendeX® External Cladding System is the RendeX® Panel manufactured from M-Grade Expanded Polystyrene (EPS) Boards. The RendeX® Panel can be one or other of the following:

- RendeX® Factory-Coated Panels, which are EPS boards factory coated on one or both sides with alkaline resistant fibreglass mesh and polymer modified cementitious basecoat ready for application of render, texture and finish coatings.
- RendeX® Applicator Coated Panels, which are EPS boards applicator coated on one side after installation by a competent tradesperson, with alkaline resistant fibreglass mesh and polymer modified cementitious basecoats, ready for application of render, texture and finish coatings.

The RendeX® Panels must be mechanically secured to a structurally adequate, external wall frame (by others).

Few, if any competitive products offer such a wide range of desirable benefits. Chief among these are superior energy efficiency and virtually unlimited design flexibility. Furthermore, the RendeX® External Cladding System has been awarded CodeMark Accreditation and is also suitable for use in Bushfire areas, with requirements up to BAL-29.

TECHNICAL MANUAL TO BE USED BY ARCHITECTS/DESIGNERS, ENGINEERS AND BUILDERS

This Manual is intended for use by qualified and experienced Architects/Designers, Engineers and Builders. The authors, publishers and distributors of this Manual and the associated drawings do not accept any responsibility for incorrect, inappropriate or incomplete use of this information.

This Manual, including the design recommendations and associated drawings, are available in electronic format, with the express intention that Architects/Designers will edit them to suit the particular requirements of specific construction projects.

BASIS OF SPECIFICATION AND DRAWINGS

This Manual has been prepared in the context of the National Construction Code (NCC). Architects/Designers, Engineers and Builders must make themselves aware of any recent changes to these documents, to any Standards referred to therein or to local variations or requirements. The authors, publishers and distributors of the referenced specifications and associated drawings do not accept any responsibility for failure to do so.

In the preparation of this Manual, the following conventions have been adopted. Architects/Designers can choose to either:

- Ensure that all building design and construction complies with the NCC and any relevant referenced documents referred to therein, including Deemed-to-Satisfy provisions, or
- Where the construction is not covered by the Deemed-to-Satisfy provisions of the NCC, the design and construction is presented as an Performance Solution and must comply with a balanced combination of Australian Standards, current practice, engineering principles and Supplier's information (refer Section 12 Certification of Performance Solution).



CODEMARK ACCREDITATION



NOTE: Refer website for latest versions of certificates.



2. ABOUT THE RendeX® PANEL

USE AND APPLICATIONS

The RendeX® Factory Coated Panel and RendeX® Applicator Coated Panel are lightweight and therefore easy to install to either timber or steel framing. They have great thermal insulation properties and therefore the RendeX® Panel has many uses in residential, commercial and industrial buildings, such as external walls, bulkheads, columns and extensions. The RendeX® Panels once rendered, textured and finish coated provide the appearance of a rendered brick wall with depth of reveal at windows that enhances the architectural appeal.

SIZES

RendeX® Panels are available as 1200mm x 2400mm sheets in the following thicknesses:

	FACTORY COATED ON ONE SIDE	50mm	75mm	100mm
	FACTORY COATED ON TWO SIDES	40mm	75mm	100mm
	APPLICATOR COATED ON ONE SIDE	50mm	75mm	100mm

75mm and 100mm RendeX® Factory Coated Panels are also available in 3000mm lengths.

75mm and 100mm RendeX® Applicator Coated Panels are also available in lengths up to 5000mm.

RendeX® EXTERNAL CLADDING SYSTEM

INSTALLATION OPTIONS

The RendeX® Panel is the key component of the RendeX® External Cladding System and can be installed in three alternate configurations:

SYSTEM 1	Vertical RendeX® Panels fixed to horizontal steel battens, on steel or timber studs
SYSTEM 2	Horizontal RendeX® Panels fixed to vertical timber battens or EPS battens or vertical steel battens on stud onto steel or timber studs
SYSTEM 3	Horizontal RendeX® Panels fixed directly to steel or timber studs

SYSTEM 1 | VERTICAL RendeX® FACTORY COATED PANELS ON HORIZONTAL BATTENS

SYSTEM 1 | VERTICAL RendeX® APPLICATOR COATE PANELS ON HORIZONTAL BATTENS

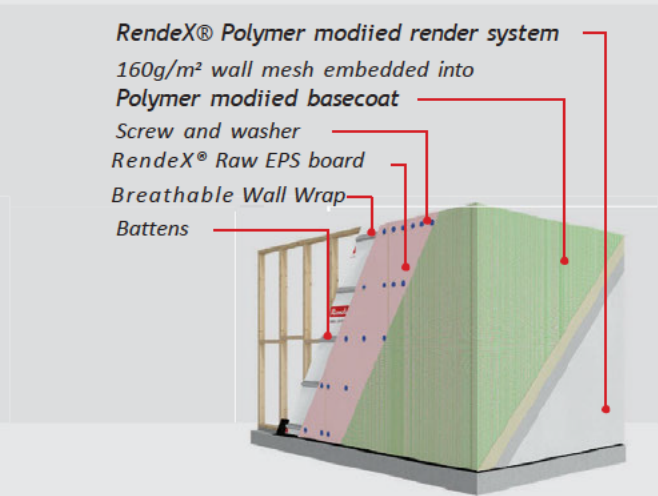
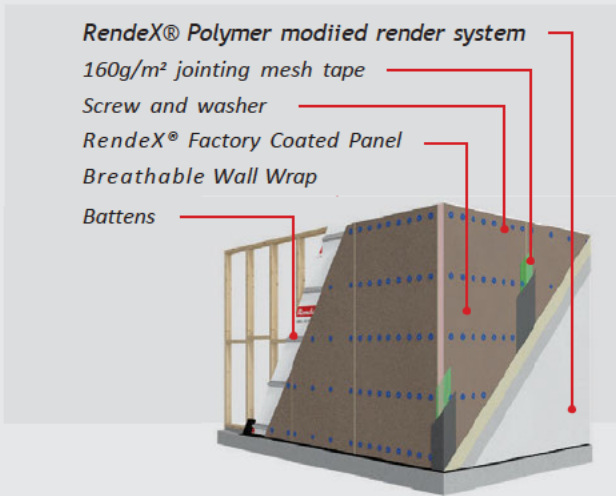

SYSTEM 2 | ORIZONTAL RendeX® FACTORY COATED PANELS ON VERTICAL BATTENS

SYSTEM 2 | HORIZONTAL RendeX® APPLICATOR COATED PANELS ON VERTICAL BATTENS

Apart from battens and panel direction, all components are similar to System 1. The advantage of this system is that moisture cannot accumulate on horizontal battens.

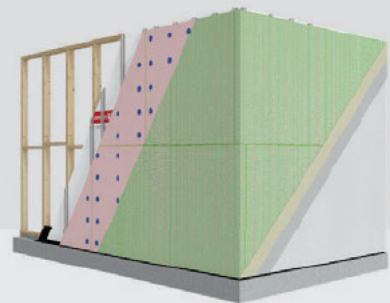
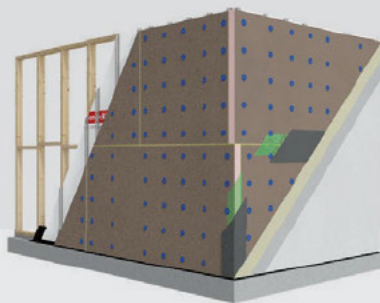

SYSTEM 3 HORIZONTAL RendeX® ACTORY COATED PANELS DIRECT FIXED TO TIMBER OR STEEL STUDS

SYSTEM 3 HORIZONTAL RendeX® APPLICATOR COATED PANELS DIRECT FIXED TO TIMBER OR STEEL STUDS

All components similar to System 2 except vertical battens are not installed. Polymer modified Render as per manufacturers specs.

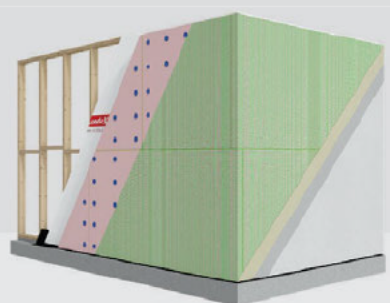
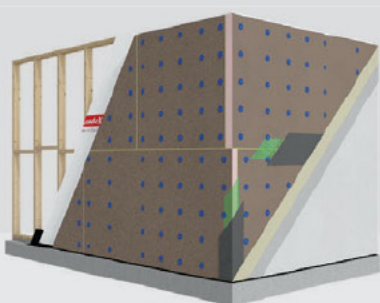

NOTES:

1. Polymer modified render system includes renders, textures and finishes, as per manufacturer's specs.
2. Where there is high risk of condensation within the wall cavity, the use of System 2 is preferable to Systems 1 and 3.

NATIONAL CONSTRUCTION CODE AND AUSTRALIAN STANDARDS

RendeX® External Cladding System applications must be designed to withstand the loads set out in the NCC and Australian Standards, as applicable. As a minimum the following Australian Standards should be considered:

AS/NZS1170.0	Structural design actions	Part 0: General principles
AS/NZS1170.1	Structural design actions	Part 1: Permanent, imposed and other actions
AS/NZS1170.2	Structural design actions	Part 2: Wind actions
AS4055	Wind loads for housing	

Wind Loads

Performance Solution Requirements

The wind loading capacity as specified in Section 12 'Certification of Performance Solution' has been determined in accordance with:

- AS/NZS1170.2 – Structural Design Actions Part 2: Wind Actions
- AS4055 – Wind Loads for Housing.

The design wind loads for a particular building may only be determined by site classification and height of the building in accordance with one of these Australian Standards.

As the RendeX® External Cladding System is not load bearing, and movement joints are specified at regular intervals, there is no specific wall height limitation for the application of the system for buildings with wind loads determined in accordance with AS/NZS1170.2.

Deemed-to-Satisfy Requirements

Where the wind loads of a Class 1 or 10 building are determined in accordance with AS4055, the building shall comply with the limitations of that standard including;

- distance from ground level to the underside of eaves shall not exceed 6.0m;
- distance from ground level to the highest point of the roof, not including chimneys, shall not exceed 8.5m;
- width including roofed verandahs, excluding eaves, shall not exceed 16.0m, and the length shall not exceed five times the width; and
- roof pitch shall not exceed 35 degrees.

The RendeX® External Cladding System when applied to the walls of a building designed for wind loads in accordance with AS4055, are capable of sustaining the design ultimate limit state wind loadings for Wind Classifications N1w, N2w, N3w, N4w.

Racking Loads

The RendeX® External Cladding System is not intended to resist racking loads. These must be resisted by appropriate bracing of the wall structure to provide both strength and a high degree of stiffness against these loads.

4. FIRE AND THERMAL PERFORMANCE

FIRE PERFORMANCE



The RendeX® Panel is made of flame-retardant modified expanded polystyrene (EPS). The RendeX® Panels are not fire rated, however the EPS will self-extinguish when the flame source is removed. Note also that the RendeX® External Cladding System has NOT been tested for fire rated construction, therefore the FRL performance is not stated and cannot be assumed.

However, the RendeX® Panel can be combined with other fire-rated components, to form part of a wall system that offers both fire-rating and thermal rating performance. Refer PWS' Sales Department for specific details.

Separation distances from flues to the adjacent faces of the RendeX® panels should be observed for the protection of the EPS material. Care must also be taken to protect heat sensitive lining/framing and finishing materials where they are used. Where penetrations are made in the RendeX® Panels for flues and the like, reference must be made to the NCC and Building Code of Australia (BCA).

THERMAL RESISTANCE OF RendeX® EXTERNAL CLADDING SYSTEM

The RendeX® External Cladding System is applied to stud framing (either timber or metal frame) with RendeX® Wall Wrap, battens, RendeX® Panels, render, texture and seal coatings. The RendeX® External Cladding System has excellent thermal resistance as set out in TABLE 1.

A 75mm thick RendeX® External Cladding System (on battens), together with 10mm plasterboard on a stud frame can provide a thermal resistance up to R2.4, without additional insulation.

A 100mm thick RendeX® External Cladding System can provide a thermal resistance up to R4.5, when additional R1.5 wall insulation is installed.

Table 1 | Thermal Resistance of RendeX® External Cladding System

THERMAL RESISTANCE OF RendeX® EXTERNAL CLADDING SYSTEM (CALCULATED)			
Thickness of EPS (mm)	Thermal Resistance of EPS – R (m ² K/W)	Total Thermal Resistance of walls made from RendeX® External Cladding System fixed to a Timber Stud Wall, with 10mm Plasterboard - R _{total} (m ² K/W)	Total Thermal Resistance of walls made from RendeX® External Cladding System fixed to Steel Battens (thermal break) on a Timber Stud Wall, with 10mm Plasterboard - R _{total} (m ² K/W)
40	1.00	1.40	1.57
50	1.20	1.60	1.77
75	1.80	2.20	2.37
100	2.40	2.80	2.97

The thermal resistance values of the EPS board are the minimum values required for compliance with AS1366.3 for Class M EPS. The Total Thermal Resistance of a completed wall is calculated using:

- **0.04m²K/W** for the external air film
- **0.01m²K/W** for 5-8mm external render
- **1.20, 1.80 or 2.40m²K/W** for 50mm, 75mm or 100mm EPS board respectively
- **0.17m²K/W** for a 20mm ventilated thermal break i.e. the RendeX® panels are fixed on battens.
- **0.00m²K/W** for the RendeX® Wall Wrap
- **0.17m²K/W** for a non-ventilated cavity not less than 70mm between the RendeX® Wall Wrap and plasterboard, bridged only by stud frames
- **0.06m²K/W** for 10mm plasterboard
- **0.12m²K/W** for the internal air film

The thermal resistance of these systems may be increased by adding bulk insulation between the studs and/or reflective foil between the studs and the plasterboard, or other proprietary insulation system.

The building design and construction process involves three principle steps:

- Design, including product selection;
- Manufacture and supply of all components; and
- Construction, including the attendant supervision, inspections and certification.

DESIGN PROCESS

The design process must encompass the selection of the appropriate product for the particular design application. The Architect/Designer and Engineer for any building project share responsibility (and authority) to determine and communicate the design (within the constraints of the NCC) to the Builders. They are required to consider all relevant matters affecting the building and its components, and determine their designs drawing on professional training, experience, peer practices, ethics, client requirements, published standards, research and the like. This information must be communicated to the Builders and Installers via drawings and specifications.

All materials and construction must comply with the most recent version of:

- the relevant parts of the Building Regulations;
- the Standards referred to therein;
- other Standards nominated in this manual; and
- other relevant Regulations.

Relevant Standards

AS1684.2	Residential Timber Framed Construction <i>Non-cyclonic areas</i>
NASH Standard	Residential and low-rise steel framing

All buildings are required to be built such that:

- The RendeX® External Cladding System is properly supported to resist horizontal wind and earthquake loads, together with vertical gravity loads;
- The building is weatherproof and durable; and
- The required thermal resistance can be achieved.

Structural Support

The specification, supply and construction of the building frames and/or structure is outside the scope of this Manual and the supply of the RendeX® External Cladding System. The Architect/Designer, Engineer and Builder must ensure the correct specification, supply and construction of appropriate frames to AS1684 (timber frames designed in accordance with AS1720.1 that provide the same degree of support e.g. support spacing, will be equally applicable), AS4600 or other appropriate standard, such that the supporting structure has sufficient combined capacity to transmit the horizontal in-plane and out-of-plane loads from the wall to the supports.

Weather-Proofing

Buildings must be correctly detailed to account for weatherproofing requirements, foundation movement, shrinkage and the efficient removal of rain water:

- Gutters and rainwater downpipes must be free draining, and connected to a functioning stormwater system.
- Flashing must be secured and joints sealed with flexible sealant e.g. silicone or similar, which must be renewed over time as they deteriorate.
- Damp-proof courses shall exclude rising ground water and the accompanying salts from contaminating the structure. The RendeX® External Cladding System does not require a proprietary damp-proof course provided the bottom of the RendeX® Starter Panel or Starter Trim is fixed at least 100mm above the finished ground level.
- The specification, supply and construction of appropriate windows and doors are outside the scope of the RendeX® External Cladding System and this Manual. The Architect/Designer, Engineer and Builder must ensure the correct specification, supply and construction of appropriate windows and doors, such that drainage holes and integral flashings drain rain water to the outside of the building and prevent the ingress of water behind the RendeX® External Cladding System.

MANUFACTURE AND SUPPLY

The RendeX® Factory Coated Panels are manufactured according to controlled work instructions and under the guidance of an approved Product Quality Plan. All raw material suppliers are expected to maintain a Quality Control process which enables full traceability.

All raw materials are checked on receipt, records are kept of production runs and the finished RendeX® Factory Coated Panels are checked prior to dispatch.

CONSTRUCTION

Correct installation of the components of the RendeX® External Cladding System is critical for achieving a structurally sound and weatherproof finished product. Sections 8 to 11 of this Manual detail typical installation requirements, to assist Designers, Architects and Builders at all stages of the project.

6. INSTALLATION OF RendeX® EXTERNAL CLADDING SYSTEM

COMMENCEMENT

Work must commence as soon as practical after, but not before:

- The structural framework has reached a stage to permit the work to proceed.
- The Builder has issued:
 - a written order advising of completion of support framing
 - the relevant contract drawings, specifications and schedule of work
 - written approval of any details provided by the Contractor

QUALIFICATIONS AND EXPERIENCE OF INSTALLERS

The RendeX® External Cladding System should only be installed by qualified and experienced carpenters or other tradesmen under the supervision of a licenced Builder, who are conversant with the installation techniques set out in this Manual.

METHODOLOGY

Refer to Sections 8 to 11 of this Manual for specific installation details.

Before fixing the RendeX® Panels ensure that the wall framing (or superstructure) is both aligned and plumb. Check that the stud and/or batten spacing does not exceed 600mm in any direction. Ensure that all RendeX® Panel edges are supported, so that fixings can be applied between 30mm to 150mm from the edge. Additional horizontal battens may be required to support vertical RendeX® Panels on both sides of a horizontal joint. Additional vertical studs and/or battens may also be required to support horizontal RendeX® Panels on both sides of a vertical joint.

When fixing RendeX® Panels within 1200mm of an external corner, provide additional studs or battens where required for the additional fastener requirements (see detailing in Sections 8, 9 and 10, where additional studs or battens are indicated with a 'red star').

- **1. DPC or Flashing** – DPC and flashings must be fixed (by others) as per the manufacturer's recommendation and approved drawings/specifications.
- **2. Breathable Wall Wrap** – Fix the permeable (breathable) wall wrap over the studs in accordance with AS4200.2, tape to frame around perimeter, joins and at all openings and penetration, before fixing battens (when required) or the RendeX® Panels.
- **3. Battens (when required) shall be fixed as per one of the following options:**
 - *System 1* – Steel top-hat sections must not be lapped, but the end of each batten must be securely fixed to the supporting structure. A 10mm gap must be provided between battens in the same horizontal line to allow for the escape of trapped moisture. The top-hat battens must be fixed according to the manufacturer's recommendation and be spaced at 600mm maximum centres.
 - *System 2* – Steel, Timber or EPS battens must only be fixed on-stud (i.e. fully supported). Vertical battens must be spaced at 600mm maximum centres.
- **4. RendeX® Starter Panel or Starter Trim** – Install RendeX® Starter Panel or Starter Trim.
- **5. Cutting** – Measure the required lengths and cut the RendeX® Panel using a straight-edge and diamond-masonry blade in a circular saw, to a tolerance of ±1mm.

- **6. Openings** – At window and door openings provide a 3mm gap between the RendeX® Panel and the window/door frames. Provide a minimum of 1 in 6 fall at window sills. Install mesh reinforced corner trim around all reveals and install butterfly meshing on corners. Install RendeX® Weatherseal Tape for rain/moisture and wind protection around windows and doors frames. Apply approved flexible sealant between the frames and finished RendeX® Panels.
- **7. Penetrations** – At meter box and stormwater penetrations provide a 3mm gap between the RendeX® Panel and the meter box or stormwater pipe. Install RendeX® Weatherseal Tape for rain/moisture and wind protection around the penetrations. Apply approved flexible sealant between the meter box or stormwater pipe and finished RendeX® Panels.
- **8. Fixing** - The RendeX® Panels should be butted together, with a maximum gap of 5mm. A clearance of not less than 100mm must be maintained between the bottom edge of any RendeX® Panel and the finished ground level. Erect each RendeX® Panel, ensuring it is square to the frame. Apply expanding foam between each RendeX® Panel (except at movement joints) and fix to the studs or battens using washers and screws (see specification for details). Screws must be driven only until the washer begins to sink into the surface of the RendeX® Panel, without damaging the fibreglass mesh of the RendeX® Factory Coated Panels or the raw EPS of the RendeX® Applicator Coated Panel.
- **9a. RendeX® Factory Coated Panel Joints (other than Movement Joints)** – After trimming back any excess expanding foam, install a 200mm wide strip of fibreglass mesh tape (160g/m²) to all RendeX® Panel joints. Ensure that the mesh overlaps the RendeX® Panel by 100mm and apply using polymer modified patching compound.
- **9b. RendeX® Applicator Coated Panel Joints (other than Movement Joints)** – After trimming back any excess expanding foam, apply polymer modified basecoat render to the raw EPS board surface, then install/embed fibreglass wall mesh (160g/m²) to the complete surface. Ensure that the mesh overlaps by 100mm when joined and apply polymer modified basecoat compound i.e. RendeX® Basecoat Render.
- **10. Horizontal Movement Joints** – Provide horizontal movement joints at vertical centres corresponding to a storey height or not exceeding 3.6m. The movement joint consists of a 10mm gap filled with a closed-cell polyethylene joint filler strip (75mm*10mm) and an approved flexible sealant (refer to manufacturer for recommended installation details). The joint filler strip is placed between the RendeX® Panel at the time of installation. Horizontal joints to dissimilar materials, other than those detailed in this Manual should be referred to the respective manufacturer for guidance.
- **11. Vertical Movement Joints** – Install vertical movement joints at horizontal centres not exceeding 4.8m. The movement joint consists of a 10mm gap, closed-cell 13mm diam. backing rod and an approved flexible sealant (refer to manufacturer for installation details). The backing rod is pressed into position after the adjoining RendeX® Panels have been rendered. Vertical joints to dissimilar materials, other than those referenced in this Manual, should be referred to the respective manufacturer for guidance.
- **12. External Corners** - Install mesh reinforced corner trim (meshed external beading) with an additional strip of 200mm wide fibreglass mesh to the side where raw polystyrene is visible. Apply with polymer modified patching compound.
- **13. Internal Corners** – Install an additional strip of 200mm wide strip of fibreglass mesh into the corner. Apply with polymer modified patching compound. Alternatively, internal corners may be detailed as a vertical movement joint.
- **14. Finish Rendering of RendeX® Panels** - Apply RendeX® polymer modified render in accordance with manufacturer's specifications. The RendeX® Panels must be rendered within two weeks of installation and must not be rendered when wet e.g. from dew, rain or frost.
- **15. Finishing RendeX® Panels** – Apply suitable texture and seal coats, according to the manufacturer's specification.

FIXING REQUIREMENTS - FOR RENDEX® FACTORY COATED PANELS

The minimum number of standard fixings for RendeX® Factory Coated Panels is summarized in TABLE 2.

Fixings must not be placed less than 30mm or more than 150mm from the edge or end of a RendeX® Panel.

Table 2 | Minimum Number of Standard Fixings for RendeX® Factory Coated Panels

MINIMUM NUMBER OF STANDARD FIXING FOR FACTORY COATED PANEL				
AS4055 Wind Classification	Panel Thickness	Maximum Stud/Batten Spacing	Maximum fixing spacing within 1200mm of	Maximum fixing spacing away from corners
N1w	40, 50, 75, 100	450	380	380
		600	380	380
N2w	40, 50, 75, 100	450	380	380
		600	380	380
N3w	40, 50	450	285	380
		600	228	380
	75, 100	450	380	380
		600	380	380
N4w	40,50	450	228	380
		600	190	285
	75, 100	450	380	380
		600	285	380

FIXING REQUIREMENTS - FOR RENDEX® APPLICATOR COATED PANELS

The minimum number of standard fixings for RendeX® Applicator Coated Panels is summarized in TABLE 3.

Fixings must not be placed less than 30mm or more than 150mm from the edge or end of a RendeX® Panel.

Table 3 | Minimum Number of Standard Fixings for RendeX® Applicator Coated Panels

MINIMUM NUMBER OF STANDARD FIXING FOR APLICATOR COATED PANEL				
AS4055 Wind Classification	Panel Thickness	Maximum Stud/Batten Spacing	Maximum fixing spacing within 1200mm of	Maximum fixing spacing away from corners
N2w	50, 75, 100	450	380	380
		600	380	380
N3w	50	450	285	285
		600	228	228
	75, 100	450	380	380
		600	380	380
N4w	50	450	190	285
		600	190	228
	75, 100	450	380	380
		600	380	380

Pressures are determined in accordance with AS4055:2021.

Each Standard Fixing consists of a 48mm diameter flexible PP washer, fixed to the supports through the RendeX® Panel by one screw.

INSPECTION AND TESTING REQUIREMENTS

Inspections and tests must be performed as defined in TABLE 4.

Table 4 | *Inspection and Testing Requirements*

INSPECTION AND TESTING REQUIREMENTS			
Item or Product	Inspection Required	Acceptance Criteria	Hold / Witness
Drawings & Specifications	Inspect controlled documents	Controlled copy of latest issue on site	Hold
Frame			
Position	Spot check	±5mm	Hold
Squareness	Spot check	±5mm	Hold
Plumbness	Spot check	±2mm in 1.2m	Hold
Samples	Visual	As per specification	Hold
Finished cladding etc	Visual + open and close all doors and windows	As per drawing and specification. Must function correctly.	Witness

DAMP-PROOF COURSE

Damp-proof course shall be installed around the perimeter of the ground floor walls frames, where a concrete rebate is provided (as per detail). By others.

RendeX® STARTER PANEL / STARTER TRIM

A Rendex starter panel panels are made of M-grade expanded polystyrene, reinforced with fiberglass mesh and factory-coated with a cementitious base coat to face and the underside.

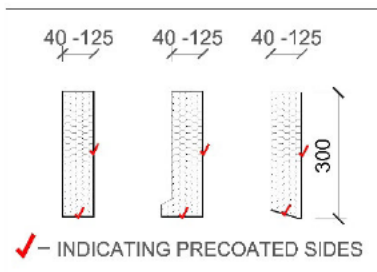

RendeX® Starter Panels function as a cavity closer but must permit drainage to the exterior of the wall. Starter Trims function in the same way.

Rendex® Starter panels for a System 1 application (horizontal battens) feature grooves at the backside facing the wall, to allow gravity-driven drainage of possible condensate. Starter Trims incorporate weep wholes on the bottom edge to allow drainage of possible condensate.

RendeX® Starter Panels and Starter Trims must be installed such that there is a minimum drip edge to the wall cladding of:

- 10mm at the base of walls.

Where Starter Trims are installed to provide intermittent support for fixings or pipe penetrations through a drained cavity, the Starter Trim must be set to a 1 in 12 fall to allow drainage of any moisture from the top.

Starter Trims must be manufactured form aluminium, with holes or slots having min and max dimension of 3 and 5mm, providing an opening area of at least 1,000mm²/m length.

BREATHABLE WALL WARP

Breathable Wall Wrap is a permeable poly-woven fabric with the following properties: Water Vapour Transmission rate not less than 140Ng/Ns, Flammability Index under 5.



BATTENS FOR CAVITY SYSTEMS

System 1 - Vertical RendeX® Panels fixed to horizontal steel battens on steel or timber studs

- Battens must be Grade G550 steel, 0.42mm BMT (base metal thickness), AZ150 (150g/m² Zinalume) aluminium/zinc coating, top-hat section, 65mm total width*30mm flange width*24mm depth.
- Battens to be fixed using 2*10g screws at each stud-frame.

Complying product: Rondo 24mm Cyclonic Ceiling Batten 303 (or equivalent)

System 2 - Horizontal RendeX® Panels fixed to vertical timber battens on steel or timber studs

- Timber battens must be H3 treated – Nominally 20mm*45mm MGP10 complying with AS1684 (minimum 45mm wide, and between 18mm and 25mm thick).
- EPS battens must be H-Grade Nominally 20mm*45mm (maximum 25mm Thick)

RendeX® PANEL (EPS) PROPERTIES

EPS board must be M-Grade, flame retardant modified in accordance with AS1366.3, with the following properties:

- Thermal resistance at a mean temperature of 23°C of a 50mm sample in accordance with AS/NZS4859.1 – not less than R1.2 (m²K/W)
- Compressive strength in accordance with AS2498.3 Method 3 – not less than 105kPa
- Cross breaking strength in accordance with AS2498.4 Method 4 – not less than 200kPa
- Water Vapour Transmission in accordance with AS2498.5 Method 5 – not more than 520mg/m²
- Dimensional stability in accordance with AS2498.6 Method 6 – not more than 1%
- Flame Propagation Surface Ignition of Vertically Oriented Specimens in accordance with AS2122.1 Method 6
 - Residue for 2sec Ignition Median Percent not less than 30%, Standard Deviation not less than 27%
 - Flame duration 5sec: Median Percent not more than 2sec, Standard Deviation not more than 3sec

- RendeX® Panel for a System 1 application (horizontal battens) feature vertical grooves to allow gravity-driven drainage of possible condensate.

EXPANDING FOAM FOR JOINS

Expanding foam for joins must be a single-component polyurethane foam, which is applied by pistol, hardens via chemical reaction with atmospheric humidity, with long shelf life, resistant to rotting and resistant to aging, resistance to temperature of hardened foam (-30°C to +80°C), non-tacky after approximately 10mins, can be cut after approximately 25mins, load-bearing after approximately 3hrs, completely hardened after approximately 5 to 8hrs (all details based on temperature of +20°C).

Complying product: HB Fuller Low Expansion Foam

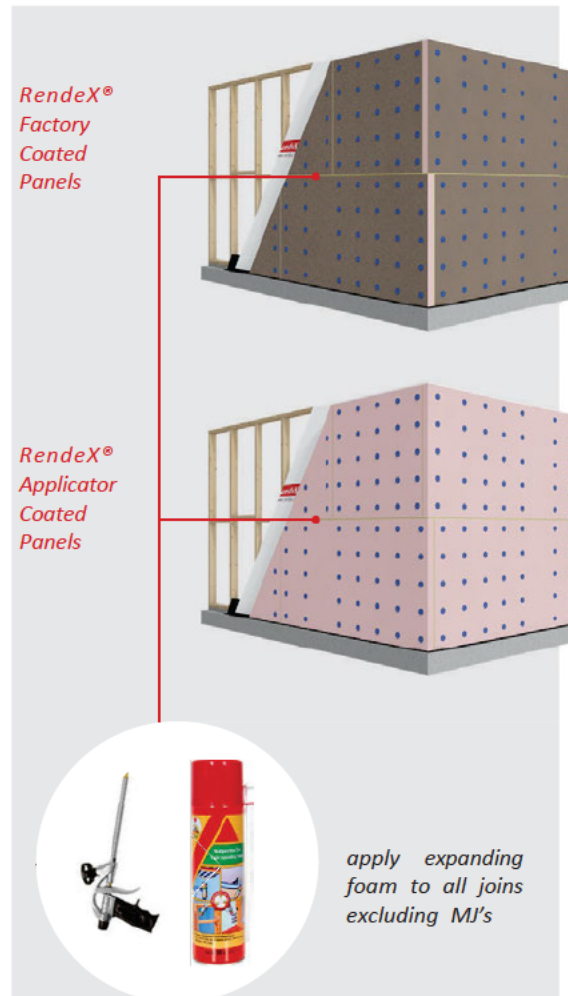

SCREW FIXINGS

Schedule of screw fixings for Systems 1, 2 and 3 are detailed in TABLE 5:

Table 5 | Schedule of Screw Fixings for Systems 1, 2 and 3

SCHEDULE OF SCREW FIXINGS		
SYSTEM	THICKNESS SECURED mm	LENGTH mm
Systems 1 Horizontal Steel Top-hat Batten	40	50
	50	65
	75	90
	100	110
Systems 2 Vertical Timber, Steel and EPS Batten	40	90
	50	100
	75	125
	100	150
Systems 3 Direct Fix	40	65
	50	75
	75	100
	100	125

Screws shall be:

- Coarse threaded (Coarse);
- At least 10 gauge (4.8mm)
- Of length at least 25mm longer than the thickness of the EPS board plus the batten (for System 2);
- At least Class 3 further than 1km from breaking surf;
- At least Class 4 further than 100m (and less than 1km) from breaking surf and fully embedded;

Grade 304 or 316 stainless steel for applications within 100m of breaking surf.

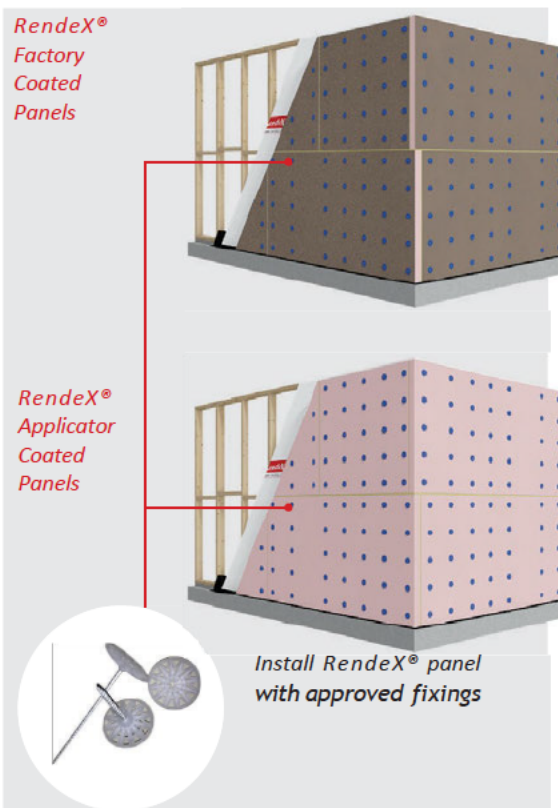

WASHERS

Washers are 48mm in diameter flexible Polypropylene (PP).

Complying product: Rendex® Washers (Product code: MA-48mmPW)

MESHED EXTERNAL BEADING

Meshed External Beading shall be either Aluminium or uPVC. uPVC beading must be polyvinyl chloride virgin material, mesh reinforced, UV stabilised, marine grade. Both shall be extruded to the specified shapes.

FIBREGLASS MESH

RendeX® Factory Coated Panels:

Meshing is required to all joints (excluding movement joints), and external corners where exposed EPS is visible, i.e. internal and external corners and openings as detailed, it must be 200mm wide, 160g/m² alkali resistant fibreglass mesh tape (as pictured and shown green in diagram).

Tape to be applied using polymer modified patching compound.

Complying product:

Site-installed - Fibreglass 5mm x 5mm mesh, 160g/m² mesh, alkali resistant.

Product code: MESH200A

RendeX® Applicator Coated Panels:

Meshing is required to whole surface of raw EPS boards (excluding movement joints), 160g/m² alkali resistant fibreglass mesh to be used (as pictured and shown green in diagram). Fibreglass mesh to be embedded in Polymer Modified Basecoat.

Complying product:

Site-installed (embedded) - Fibreglass 5mm x 5mm mesh, 160g/m² mesh, alkali resistant.

Product code: MESH1200

Polymer modified Basecoat.

Product code: RR-BASECOAT

Window openings and penetrations:

Refer to installation details of this Manual. Sections 8,9 and 10.

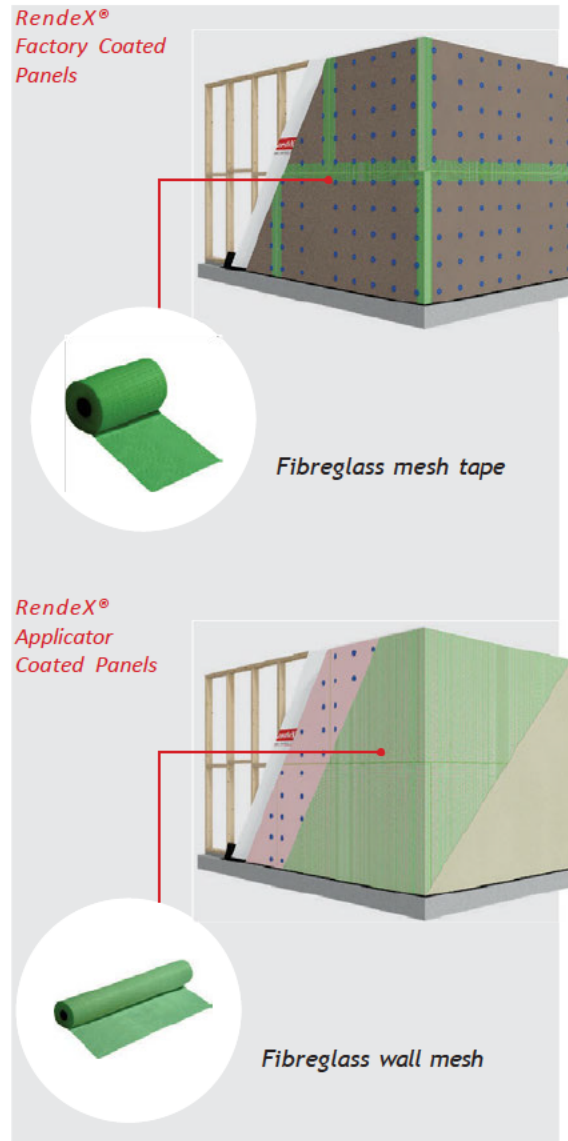

RENDERING

Render must be pre-blended polymer modified cement render, suitable for mixing with water immediately before use to provide a smooth, trowel-able paste.

Fine Joint Patch: (pre-coated panels): firmly fix and prepare all Joints, Beads and Trim by applying a thin layer of Fine Joint Patch.

Base Coat: After patch, apply two coats of base coat render 3 to 5mm thick for each coat. Should be applied to the entire wall area.

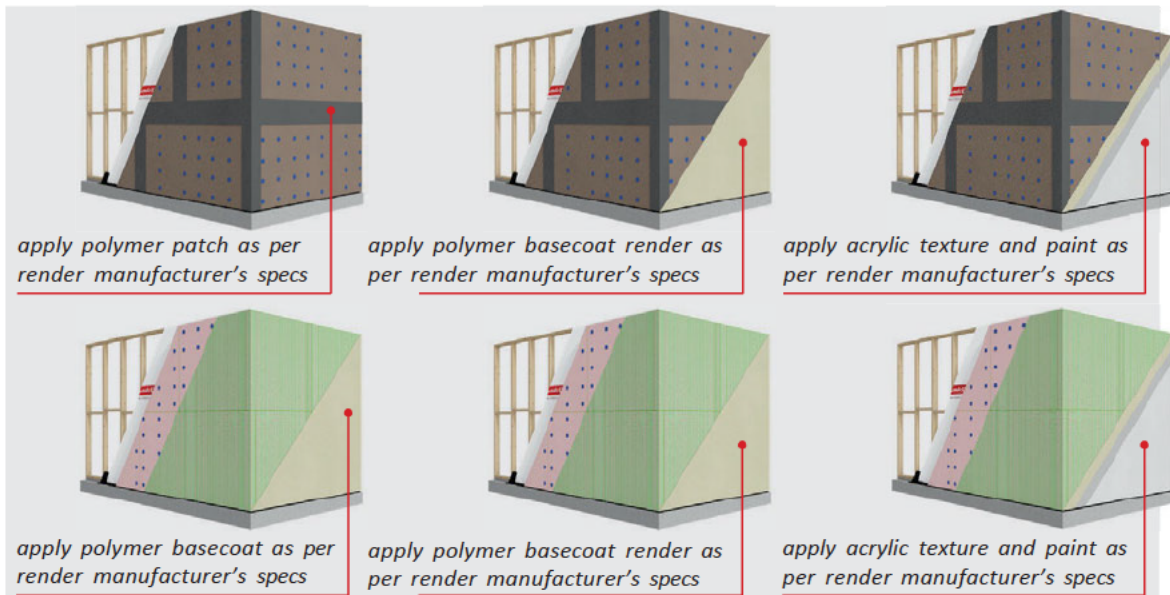

Texture finish must be acrylic based texture coating suitable for external application over cement rendered surfaces. Membrane Paint finish must consist of an acrylic external coating system, applied according to the manufacturer's specification.

Complying product:

RendeX® Factory Coated Panels: RendeX® Basecoat or proprietary systems compliant with the specification above are deemed suitable.

RendeX® Applicator Coated Panels: RendeX® Basecoat or proprietary systems approved by PWS.

Texture Coat: If required, applied directly to the base render.

Finish Membrane Coating: Applied on top of the base coat or texture coat to give a durable, weatherproof, crack-resistant finish.

MOVEMENT JOINT MATERIALS

FULAFLEX 550 PU LM

Fulaflex 550 PU LM is a one-component moisture-curing low modulus Class A polyurethane sealant with excellent joint movement capabilities. It cures into a flexible, durable and weather resistant sealant and exhibits excellent adhesion to a wide range of substrates. Fulaflex 550 PU LM is low in VOC (<60g/L) and satisfies the requirements for the Green Building Council of Australia (GBCA).



INSTALLATION DETAILS | **SYSTEM 1**

Vertical RendeX® Panel fixed to horizontal steel battens on steel/timber studs

FIXING LOCATIONS

Fixing and stud locations: Vertical RendeX® panels fixed to horizontal battens on steel or timber studs.

★ Indicates additional studs and noggings to provide required support.

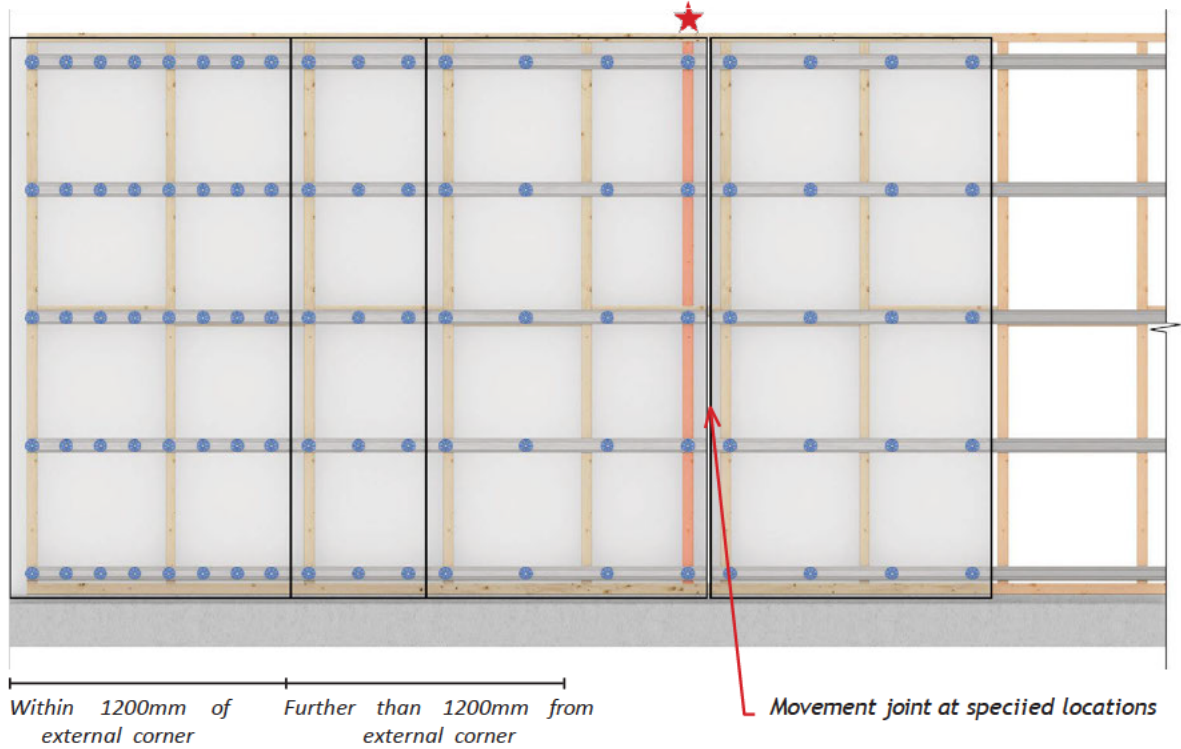

Fixings must not be placed less than 30mm or more than 150mm from the edge or end of a panel.

STEP BY STEP

RendeX® Factory Coated Panels

STEP 1 | Install DPC (by others)

STEP 2 | Install Breathable Wall Wrap

STEP 3 | Install horizontal battens



STEP 4 | Cut panel to size

STEP 5 | Fix panel with screws and washers

STEP 6 | Fill gaps between the panels with expanding foam

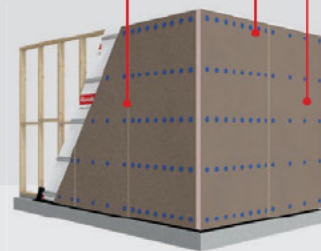

STEP 7 | Install ibreglass mesh tape to joints and corners
Apply extra mesh tape to external corner

STEP 8 | Patch with patching compound

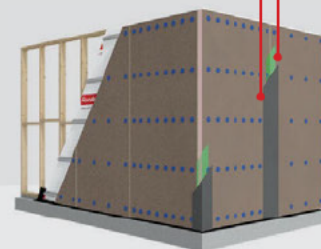

STEP 9 | Apply RendeX® Basecoat acrylic render to manuf. specs

STEP 10 | RendeX® Texture

STEP 11 | Acrylic paint membrane

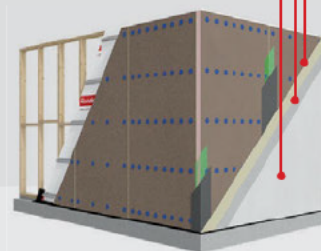

RendeX® Applicator Coated Panels

STEP 1 | Install DPC (by others)

STEP 2 | Install Breathable Wall Wrap

STEP 3 | Install horizontal battens



STEP 4 | Cut raw EPS board to size

STEP 5 | Fix board with screws and washers

STEP 6 | Fill gaps between the boards with expanding foam

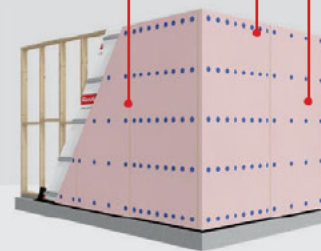

STEP 7 | Render with RendeX® Basecoat acrylic render

STEP 8 | Embed ibreglass mesh to whole surface
Apply extra mesh to external corner

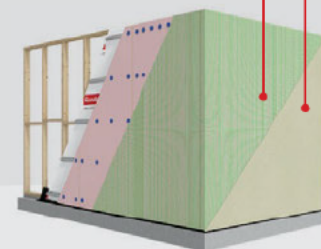

STEP 9 | Apply another coat of RendeX® Basecoat acrylic render to manuf. specs

STEP 10 | RendeX® Texture

STEP 11 | Acrylic paint membrane

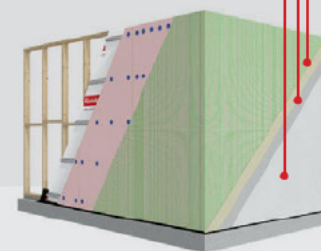

GENERAL ARRANGEMENT SYSTEM 1

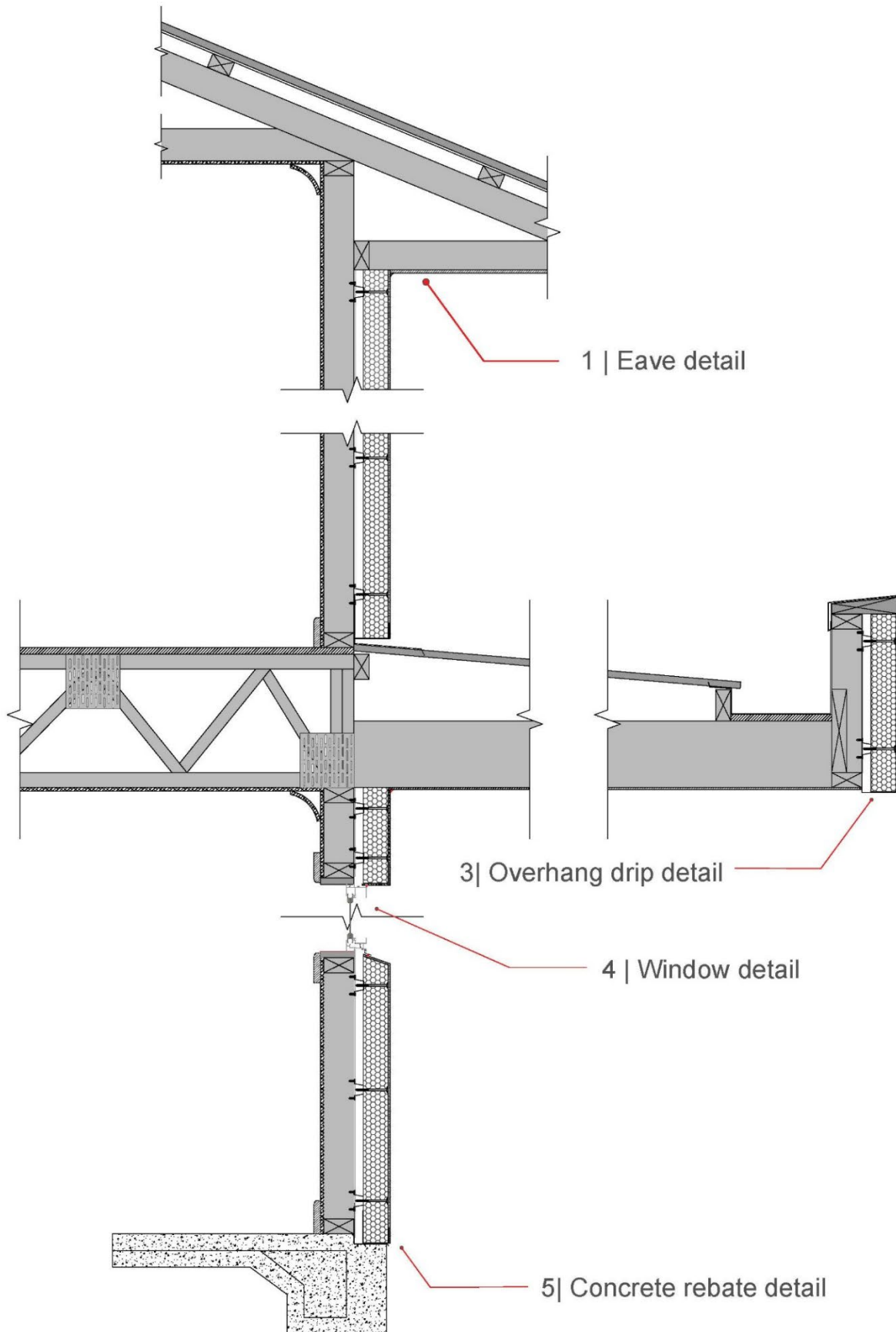

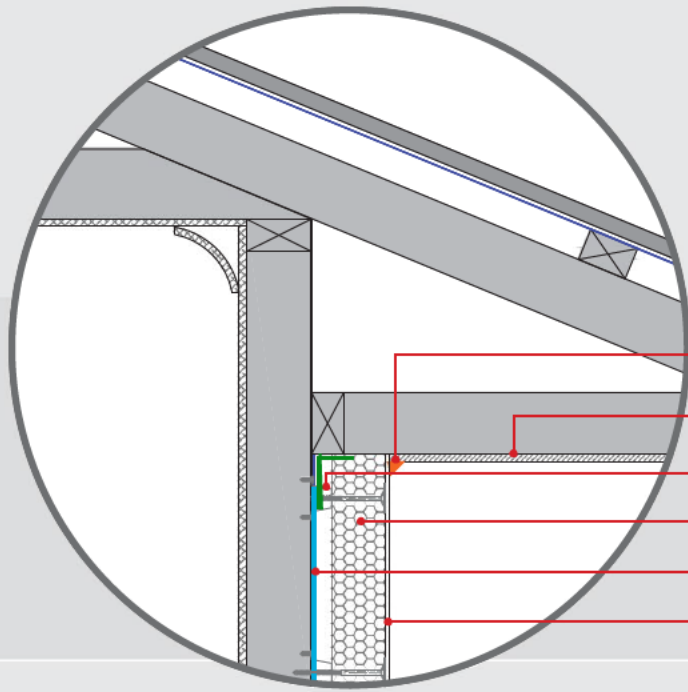

**EAVE DETAIL | OPTION A
SYSTEM 1**

Approved sealant

Eave lining (by others)

Tophat

RendeX® Panel

Breathable Wall Wrap tape to frame

Acrylic render

1A

**EAVE DETAIL | OPTION B
SYSTEM 1**

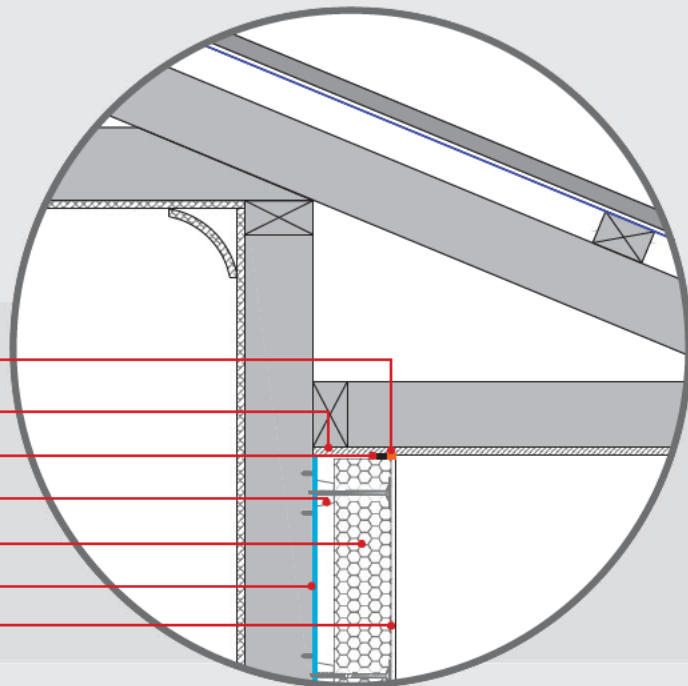

Approved sealant

Eave lining (by others)

Backing rod

Tophat

RendeX® Panel

Breathable Wall Wrap tape to frame

Acrylic render

1B

LOWER ROOF JUNCTION DETAIL | SYSTEMS 1

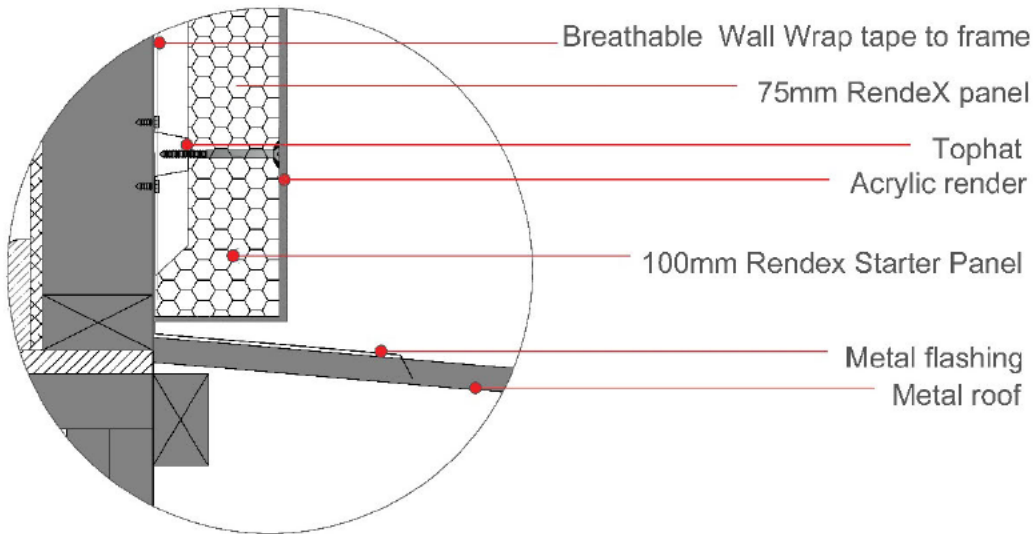
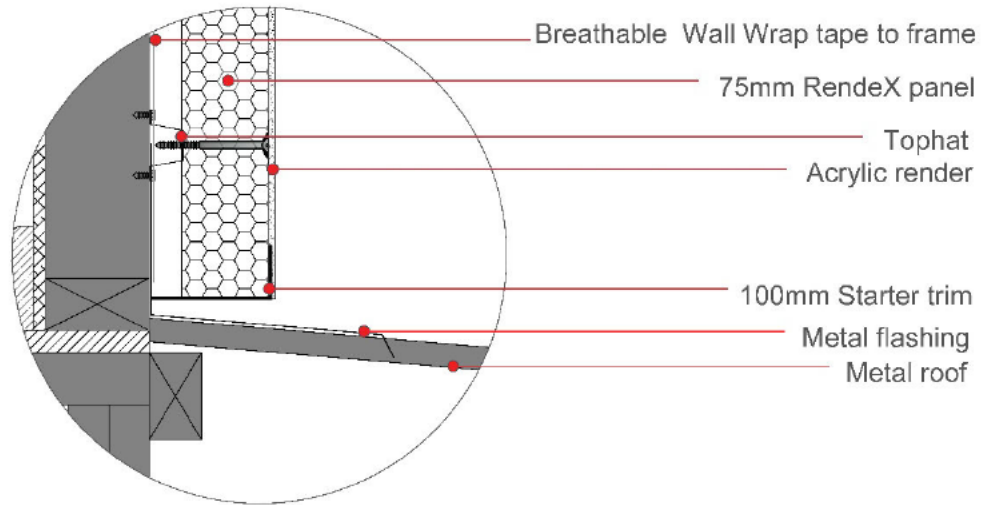

OVERHANG DRIP DETAIL | SYSTEMS 1

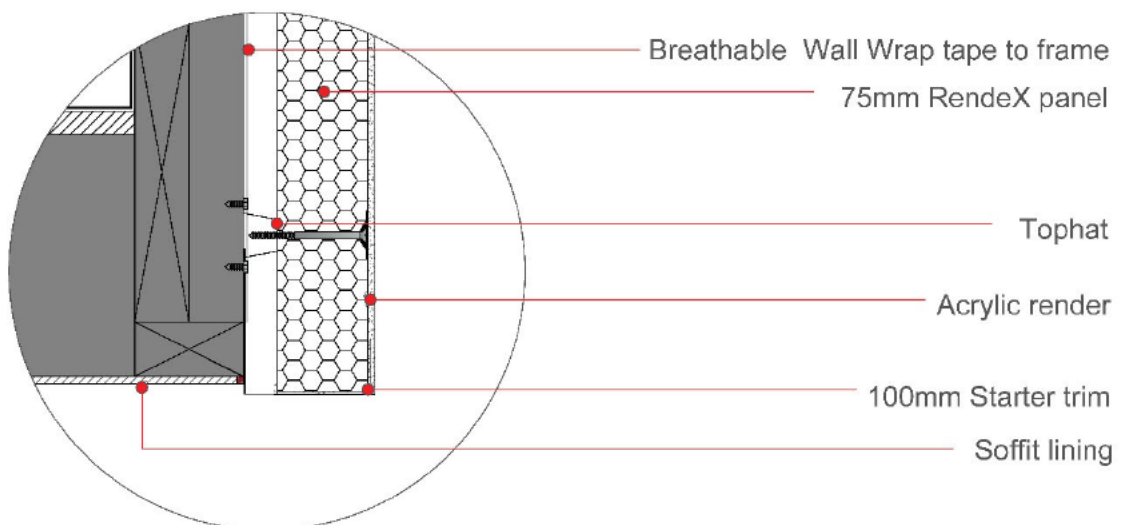

WINDOW DETAIL | SYSTEMS 1

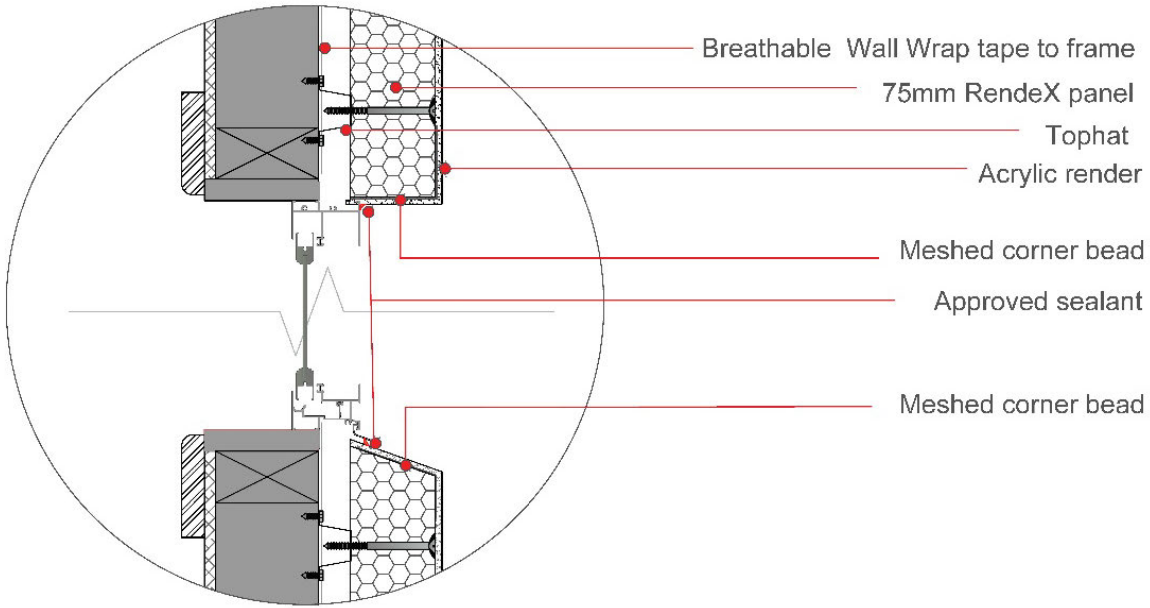

CONCRETE REBATE WITH STARTER TRIM DETAIL | SYSTEMS 1

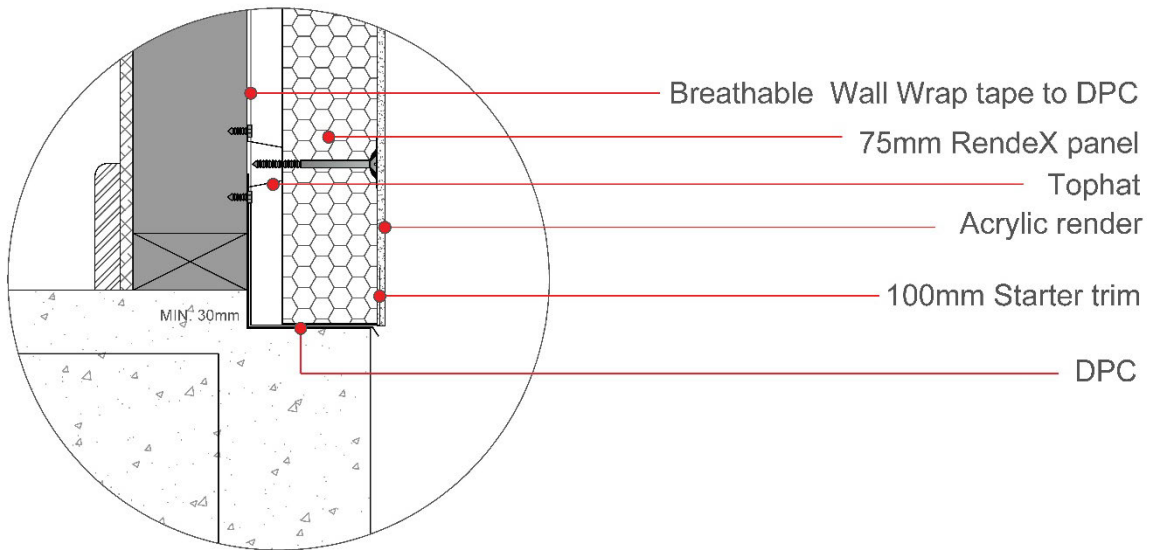

CONCRETE REBATE DETAIL WITH STARTER PANEL | SYSTEMS 1

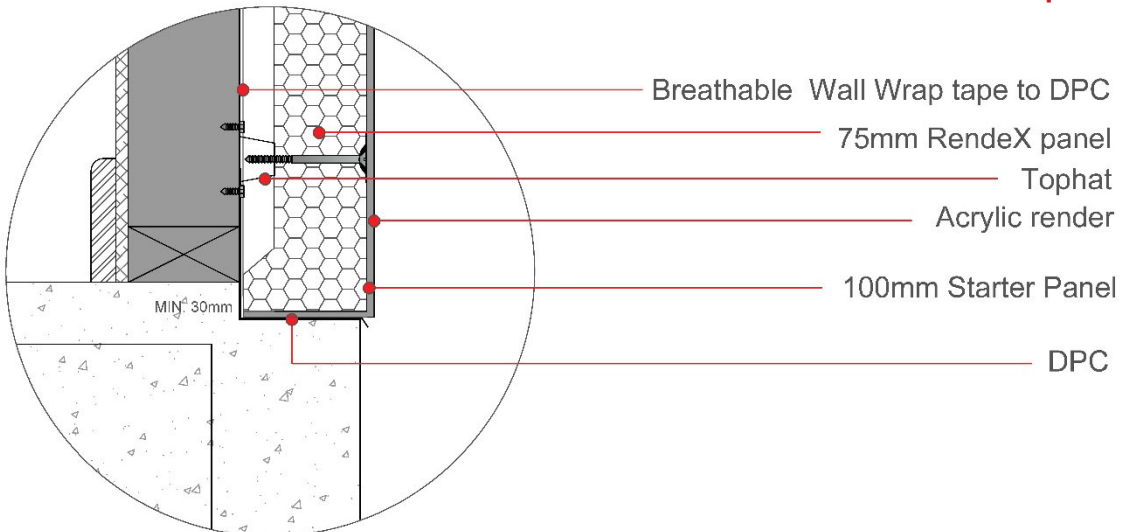

RendeX® AND BRICK VENEER DETAIL | SYSTEMS 1

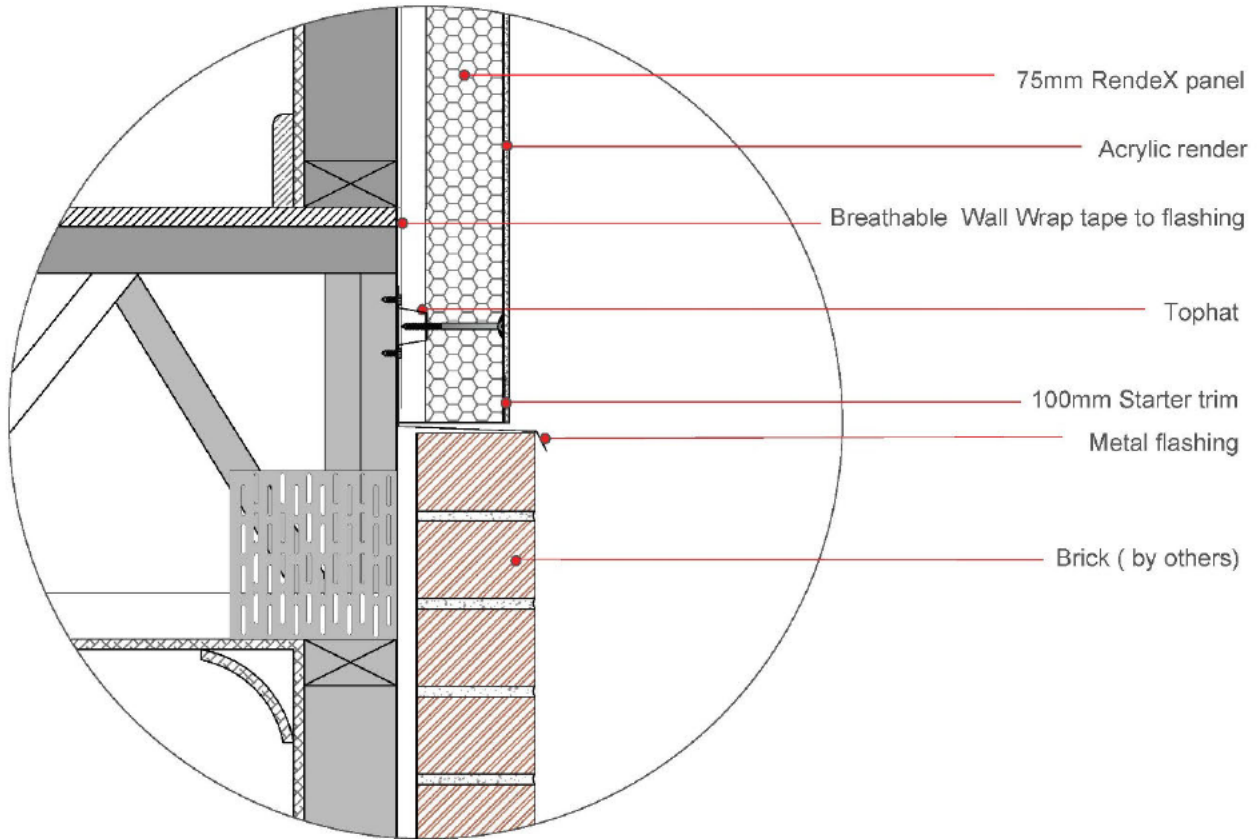

DISSIMILAR SUBSTRATES HORIZONTAL MOVEMENT JOINT DETAIL | SYSTEMS 1

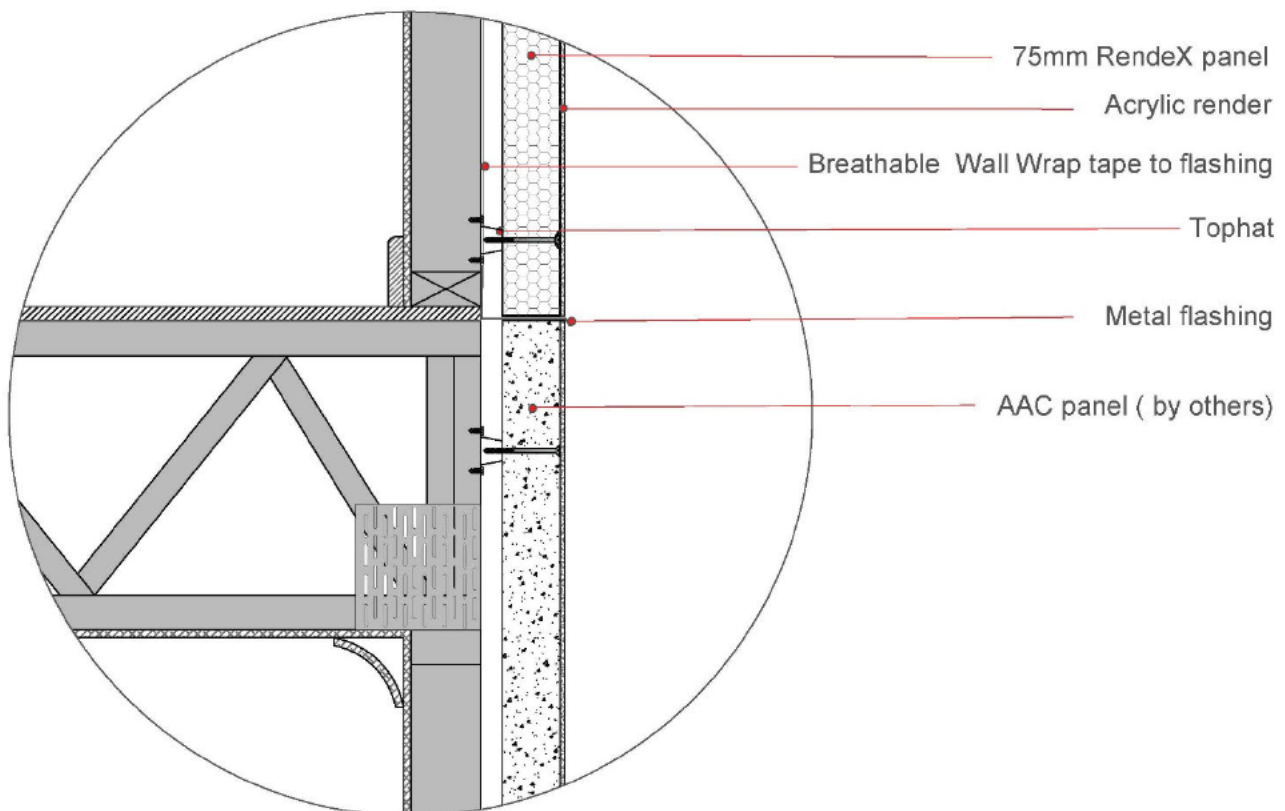

VERTICAL MOVEMENT JOINT DETAIL | SYSTEMS 1

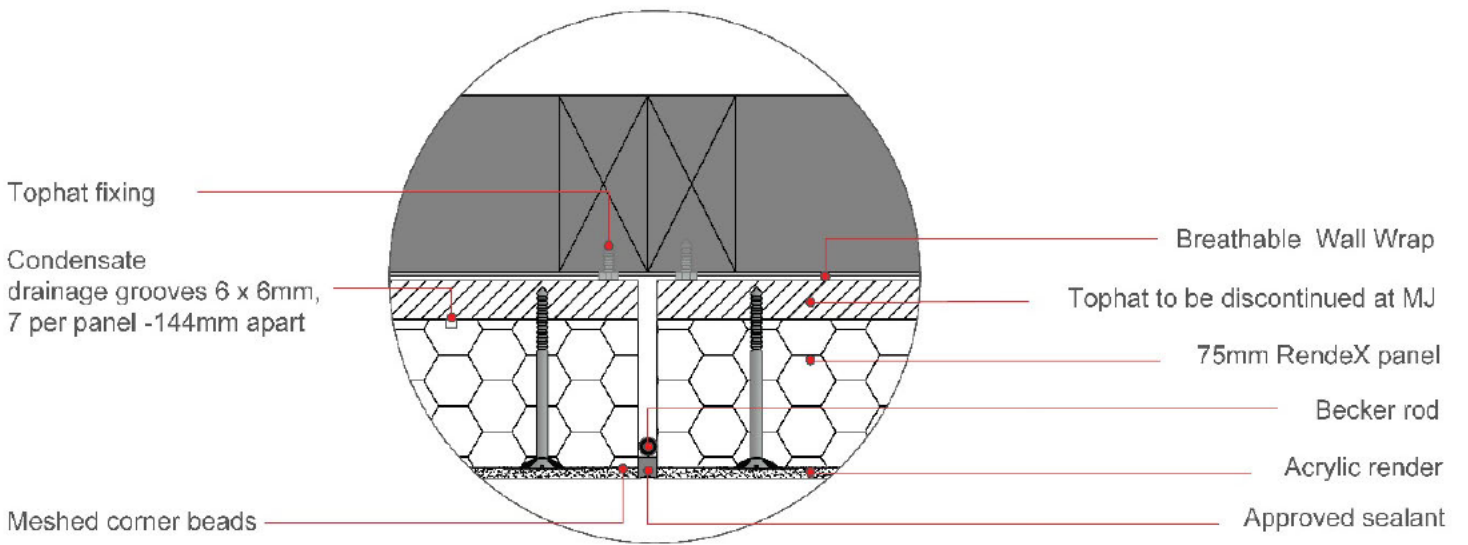
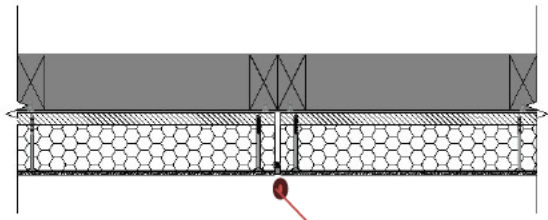

INTERNAL CORNER DETAIL | SYSTEMS 1

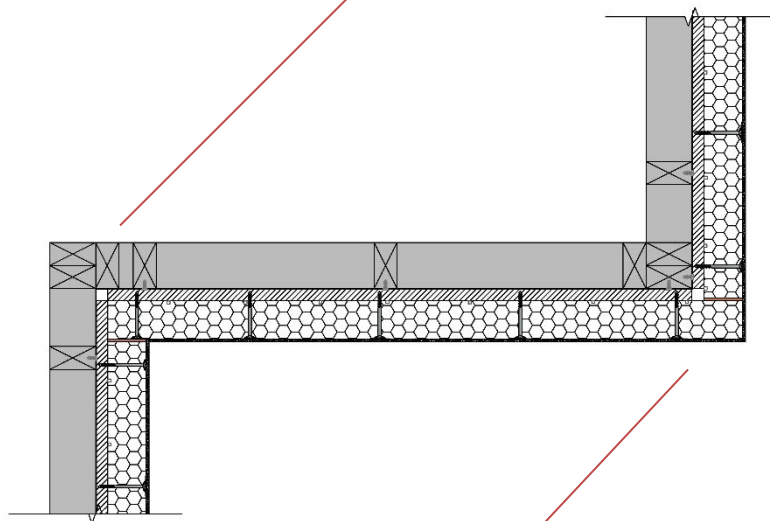
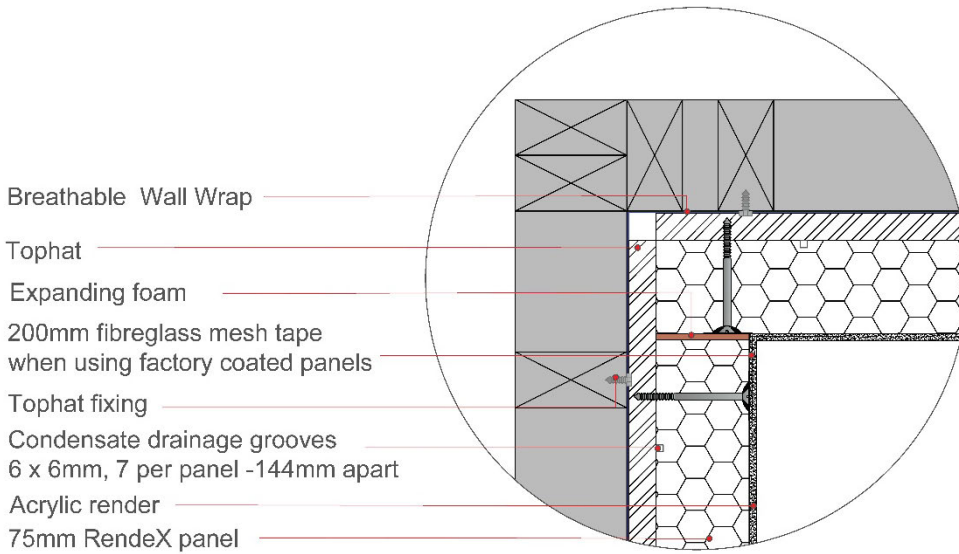

EXTERNAL CORNER DETAIL | SYSTEMS 1

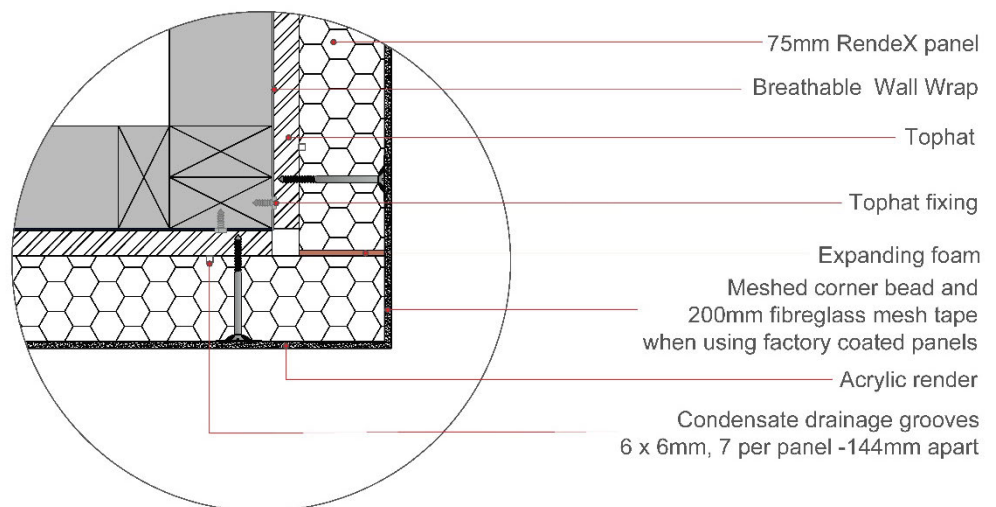

GROUND SLAB DETAIL WITH STARTER TRIM | SYSTEMS 1

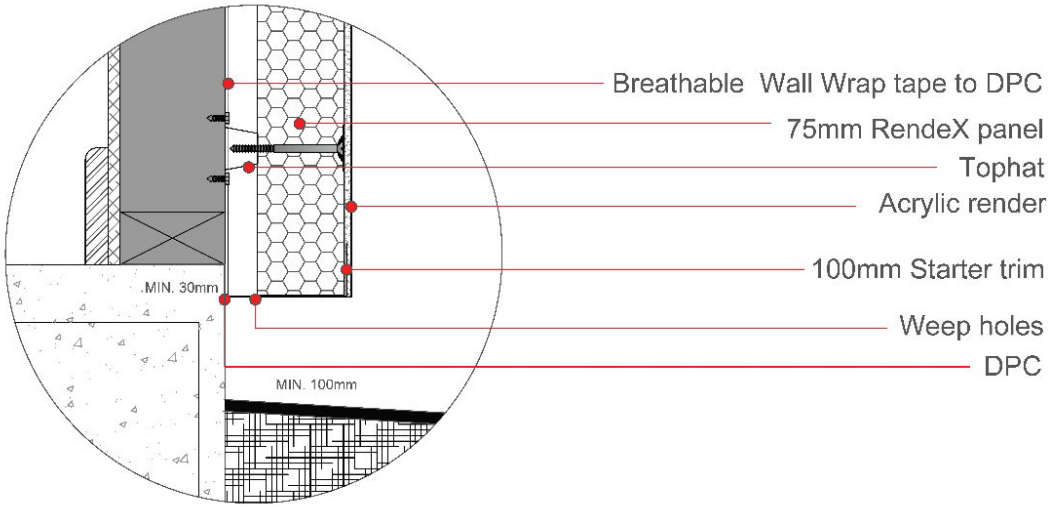

GROUND SLAB DETAIL WITH STARTER PANEL | SYSTEMS 1

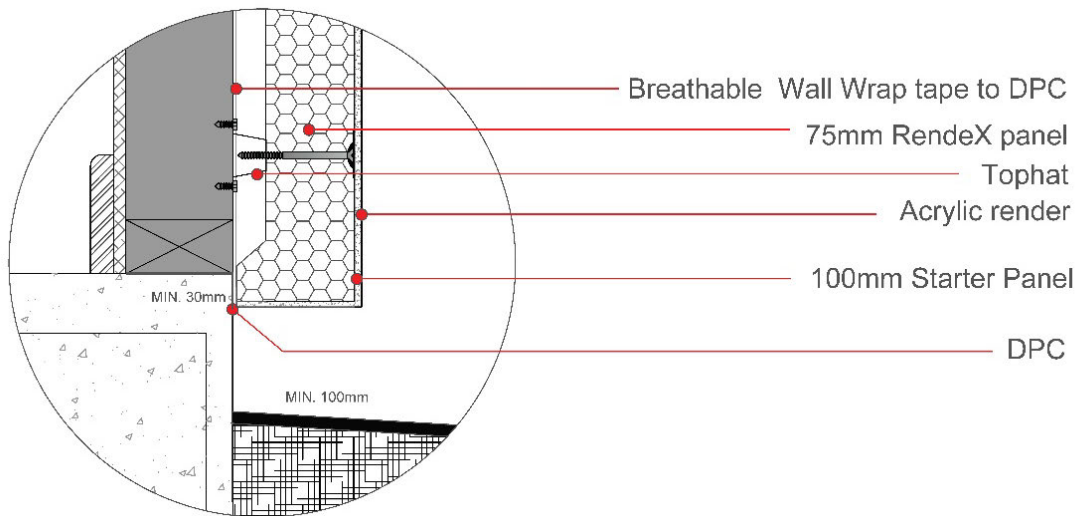

DOWNPIPE FIXING DETAIL | SYSTEMS 1

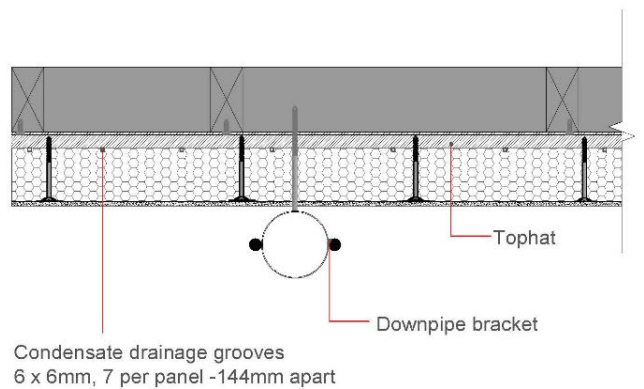
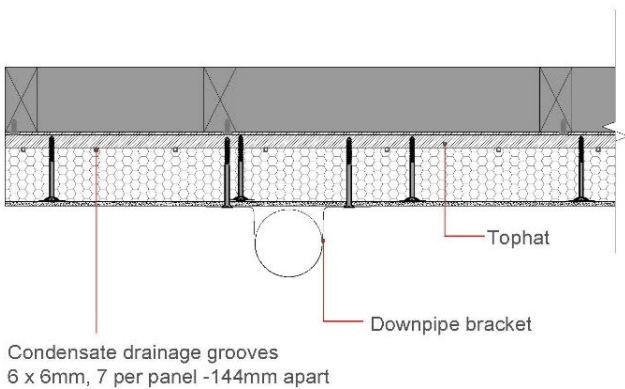

PARAPET/BALUSTRADE WITH SADDLE FLASHING SYSTEM 1

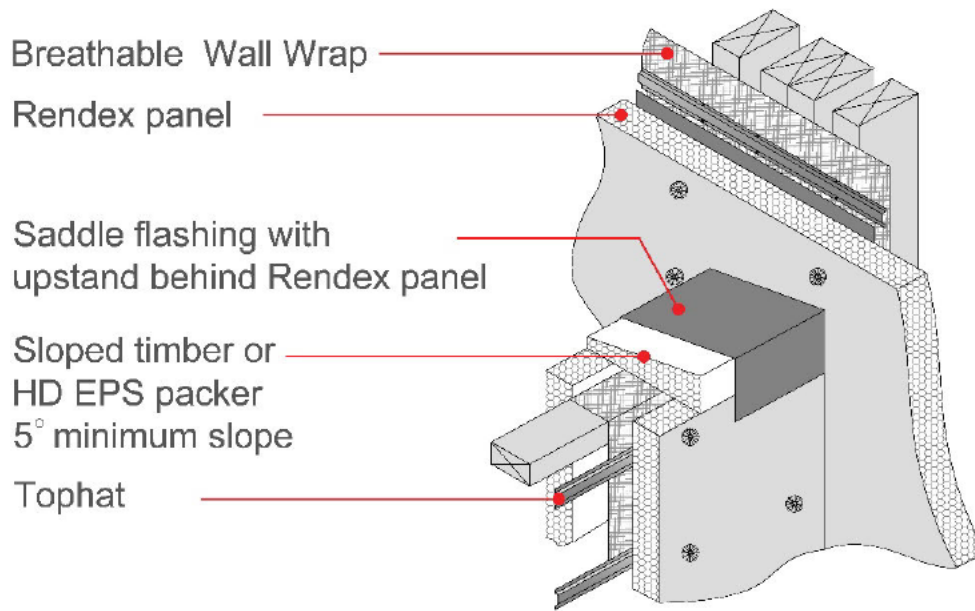

PARAPET / PENETRATION DETAIL | SYSTEM 1

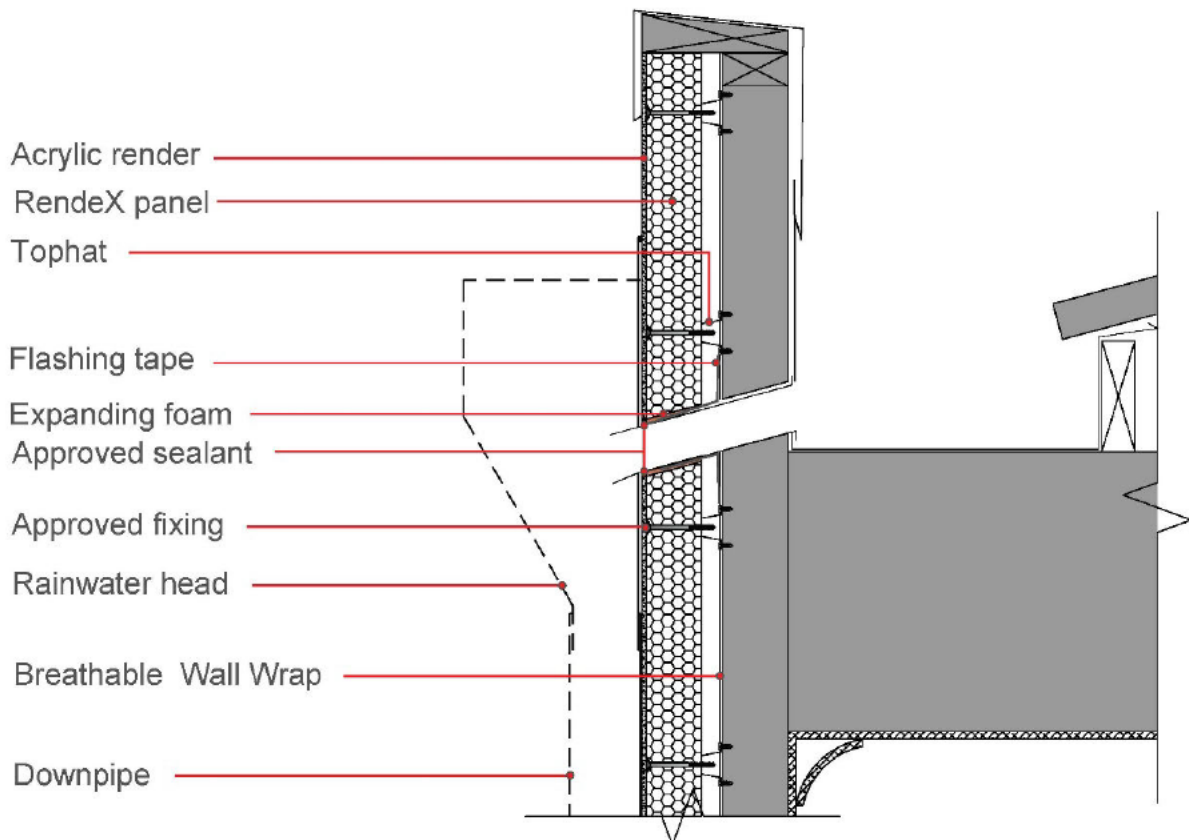



INSTALLATION DETAILS | **SYSTEM 2**

Horizontal RendeX® Panel fixed to vertical timber battens on steel/timber studs

FIXING LOCATIONS

Fixing and stud locations: Horizontal RendeX® panels fixed to vertical battens on steel/timber studs.

★ Indicates additional studs to provide required support.

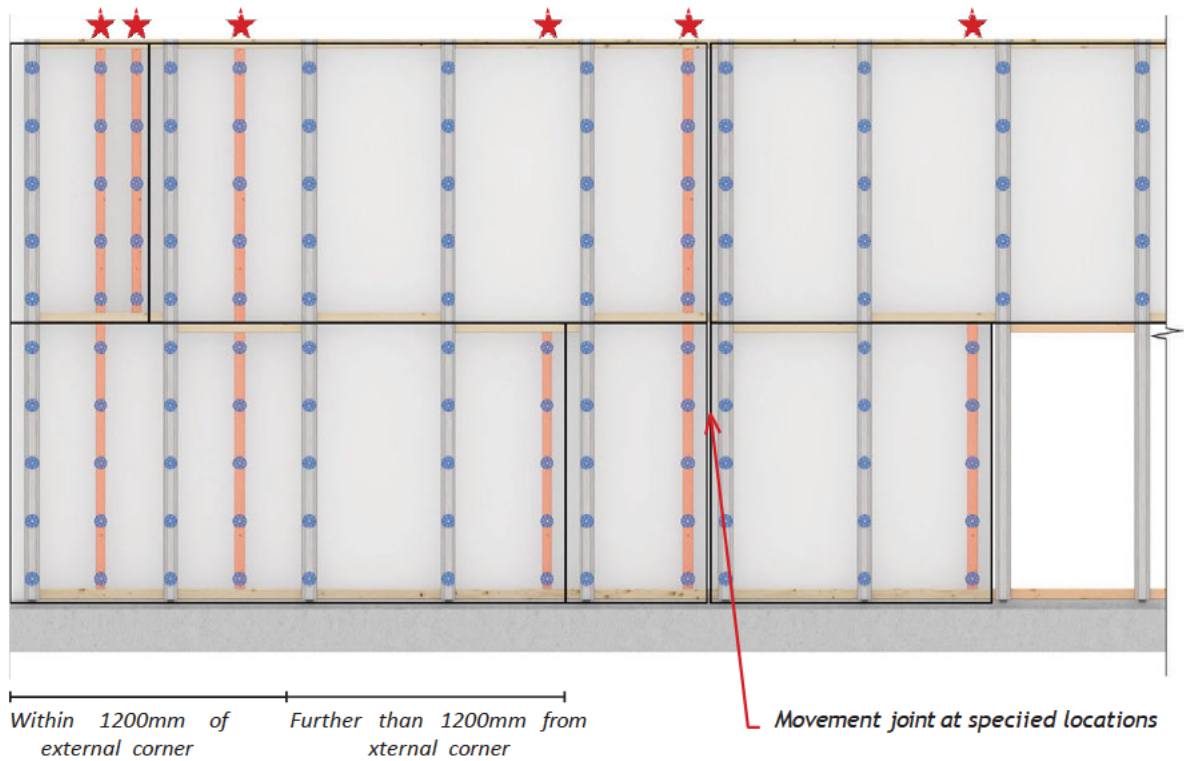

Fixings must not be placed less than 30mm or more than 150mm from the edge or end of a panel.

STEP BY STEP

RendeX® Factory Coated Panels

STEP 1 | Install DPC

STEP 2 | Install Breathable Wall Wrap

STEP 3 | Install vertical battens



STEP 4 | Cut panel to size

STEP 5 | Fix panel with screws and washers

STEP 6 | Fill gaps between the panels with expanding foam

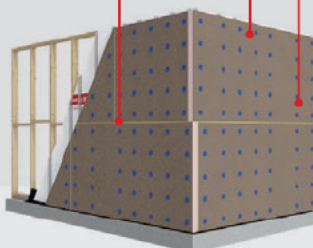

STEP 7 | Install iberglass mesh tape to joints and corners
Apply extra mesh tape to external corner

STEP 8 | Patch with patching compound

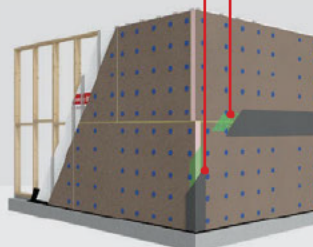

STEP 9 | Apply RendeX® Basecoat acrylic render to manuf. specs

STEP 10 | RendeX® Texture

STEP 11 | Acrylic paint membrane

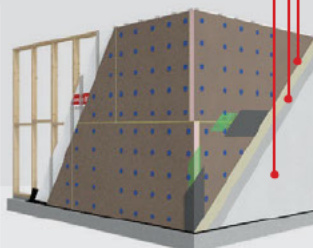

RendeX® Applicator Coated Panels

STEP 1 | Install DPC

STEP 2 | Install Breathable Wall Wrap

STEP 3 | Install vertical battens



STEP 4 | Cut raw EPS board to size

STEP 5 | Fix board with screws and washers

STEP 6 | Fill gaps between the boards with expanding foam

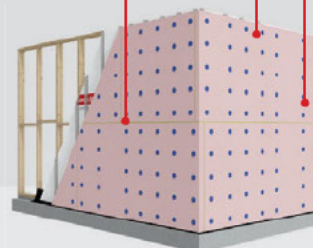

STEP 7 | Render with RendeX® Basecoat acrylic render

STEP 8 | Embed iberglass mesh to whole surface
Apply extra mesh to external corner

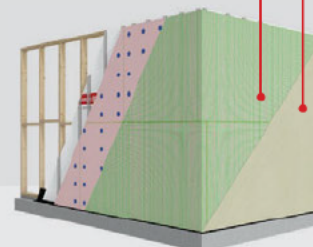

STEP 9 | Apply additional coat of RendeX® Basecoat acrylic render to manuf. specs

STEP 10 | RendeX® Texture

STEP 11 | Acrylic paint membrane

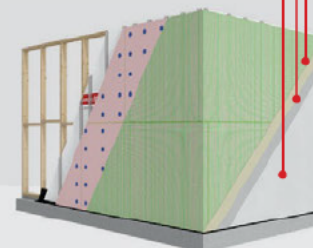

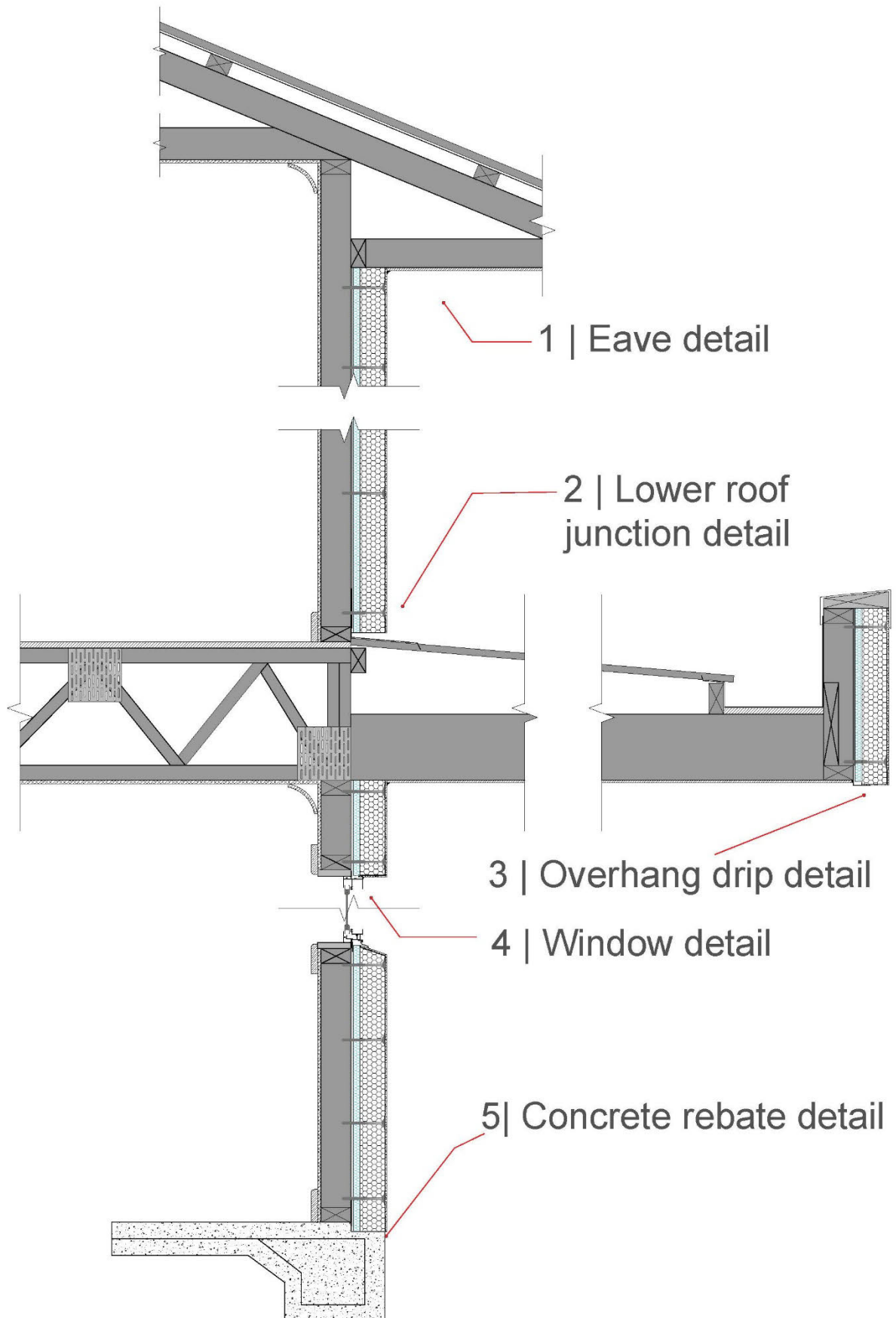

EAVE DETAIL OPTION A SYSTEM 2

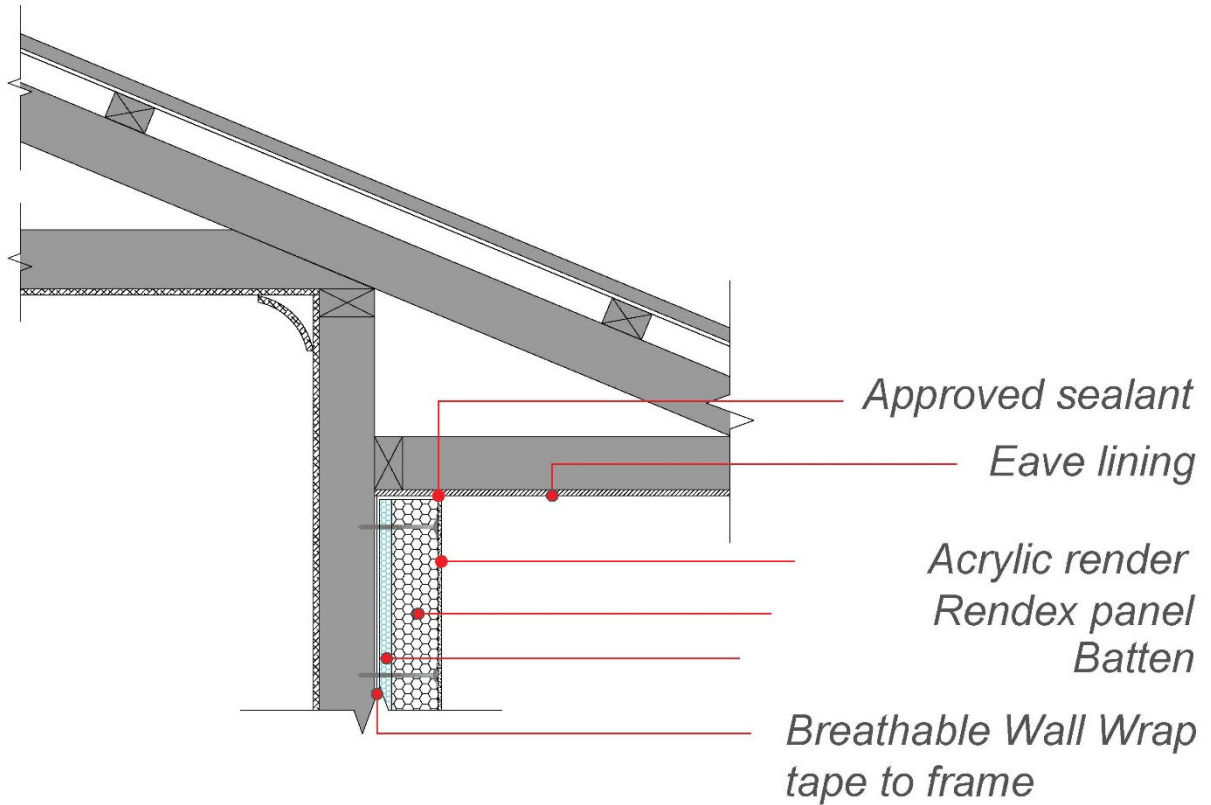

EAVE DETAIL OPTION B SYSTEM 2

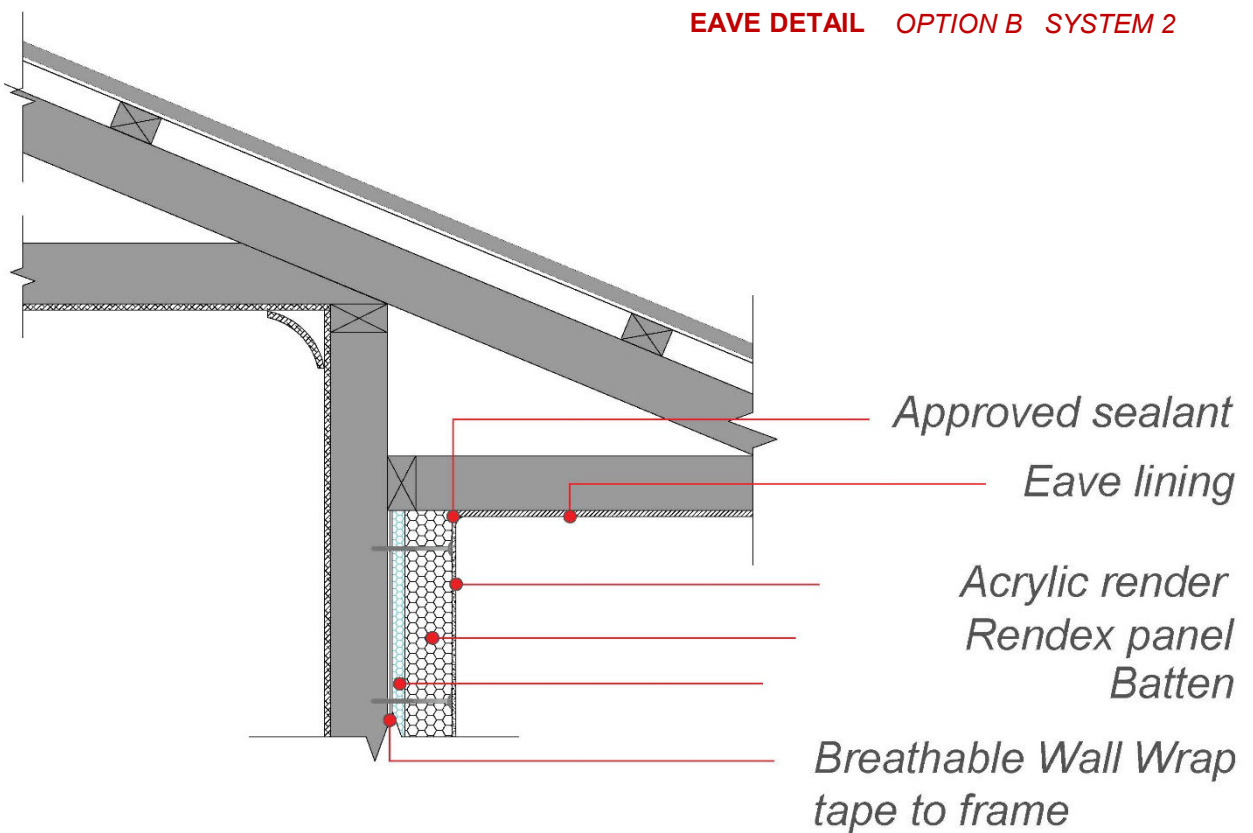

LOWER ROOF JUNCTION DETAIL WITH STARTER TRIM SYSTEM 2

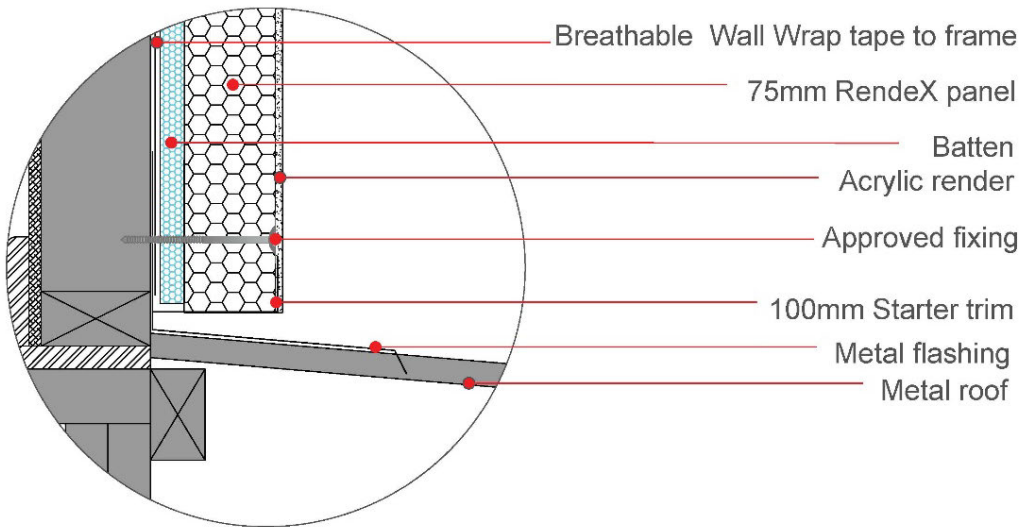

LOWER ROOF JUNCTION DETAIL WITH STARTER PANEL SYSTEM 2

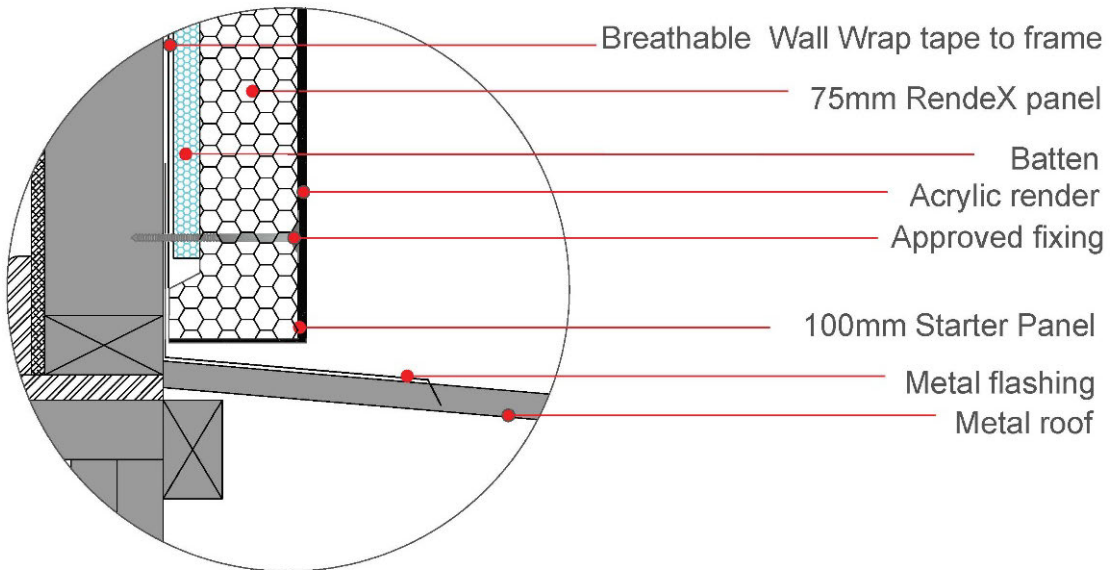

OVERHANG DRIP DETAIL SYSTEM 2

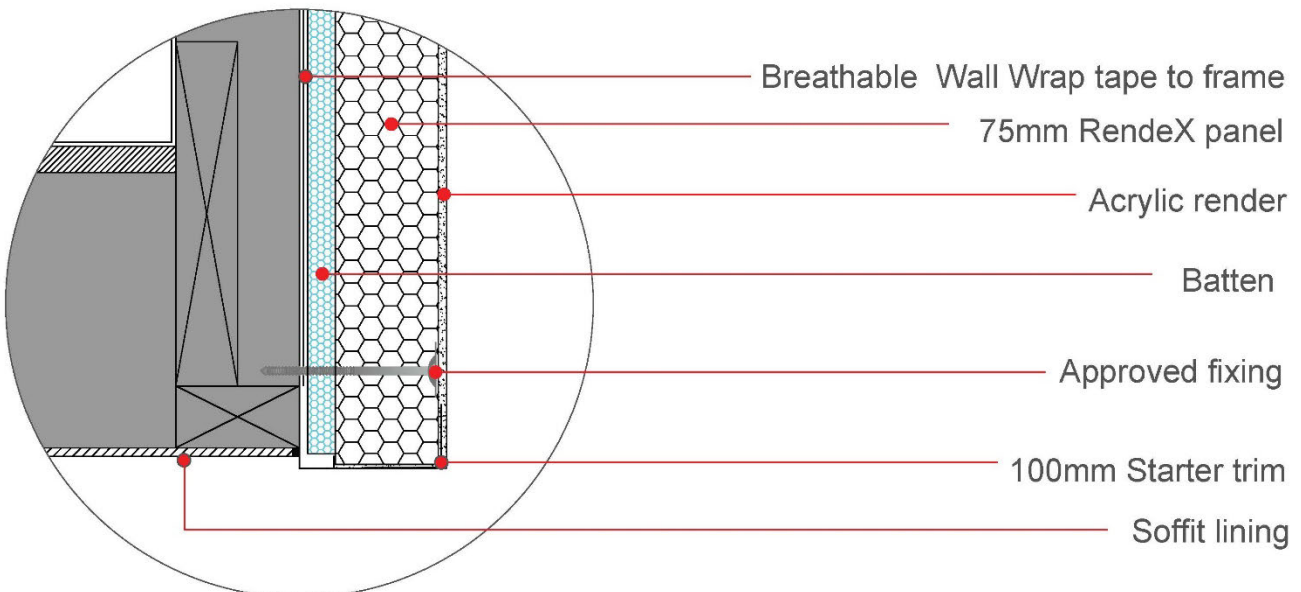

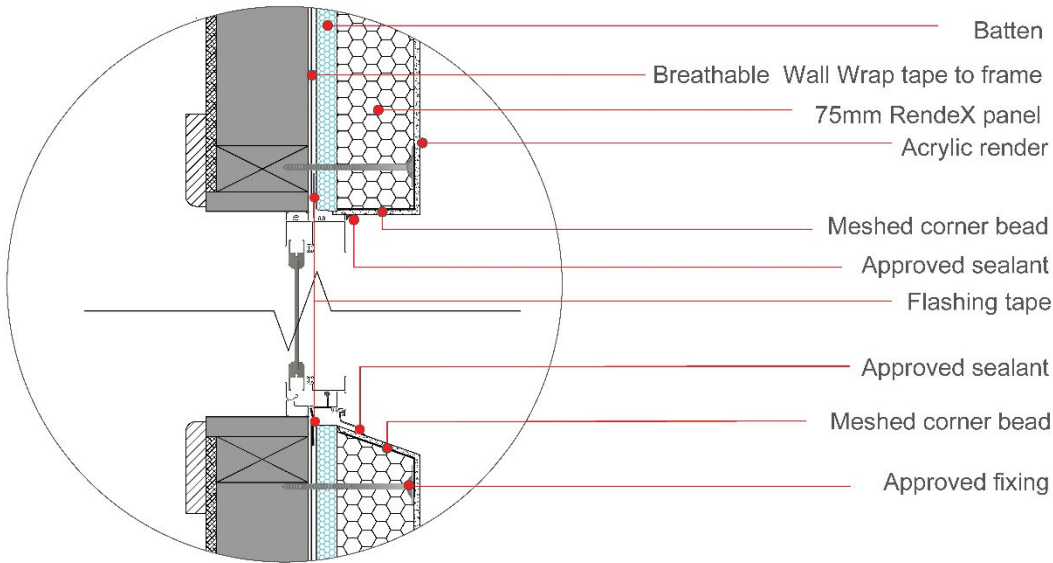

CONCRETE REBATE DETAIL SYSTEM 2

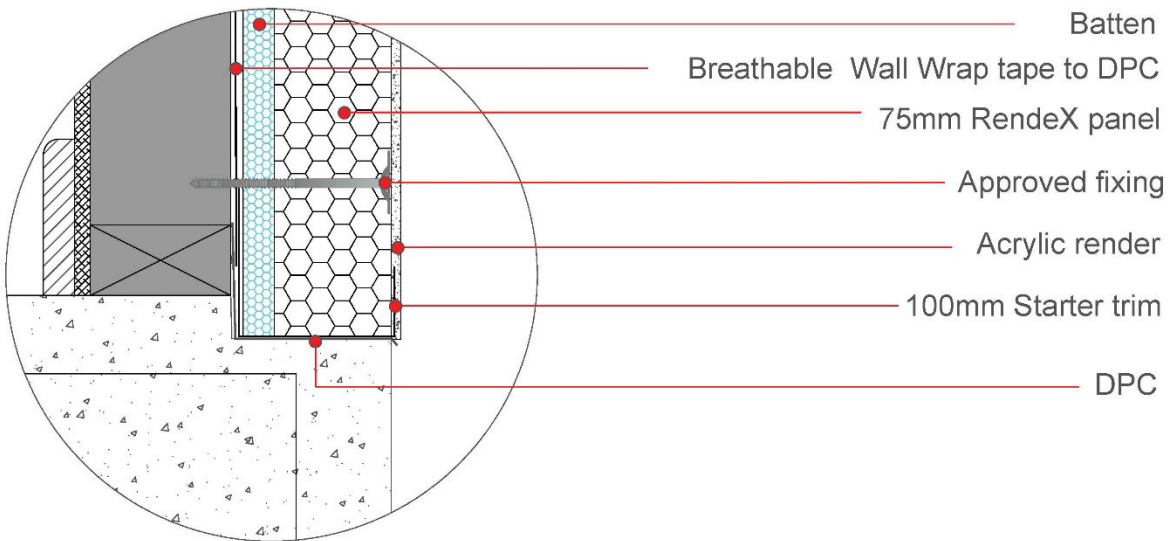

CONCRETE REBATE DETAIL WITH STARTER PANEL SYSTEM 2

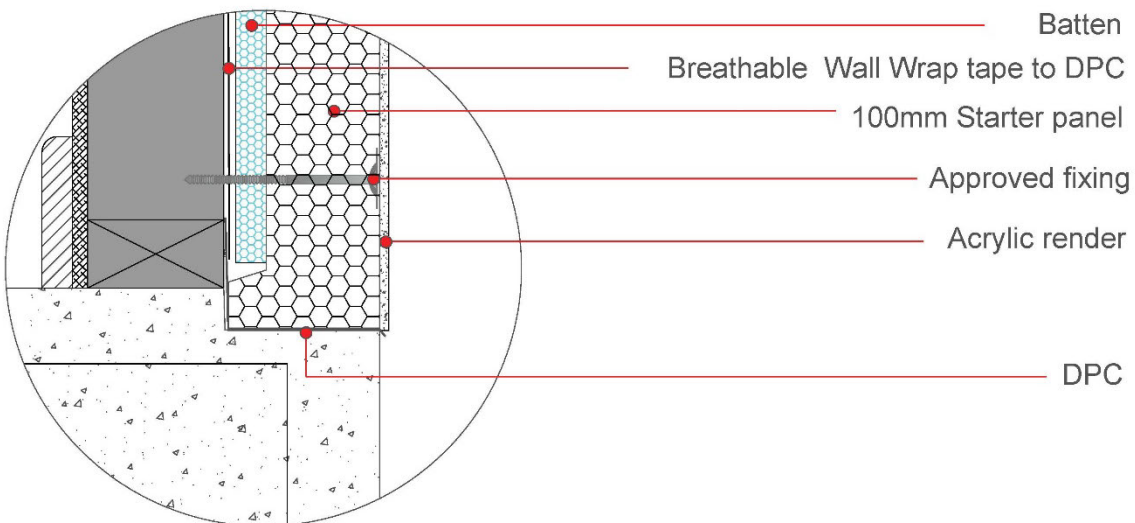

RendeX AND BRICK VENEER DETAIL SYSTEM 2

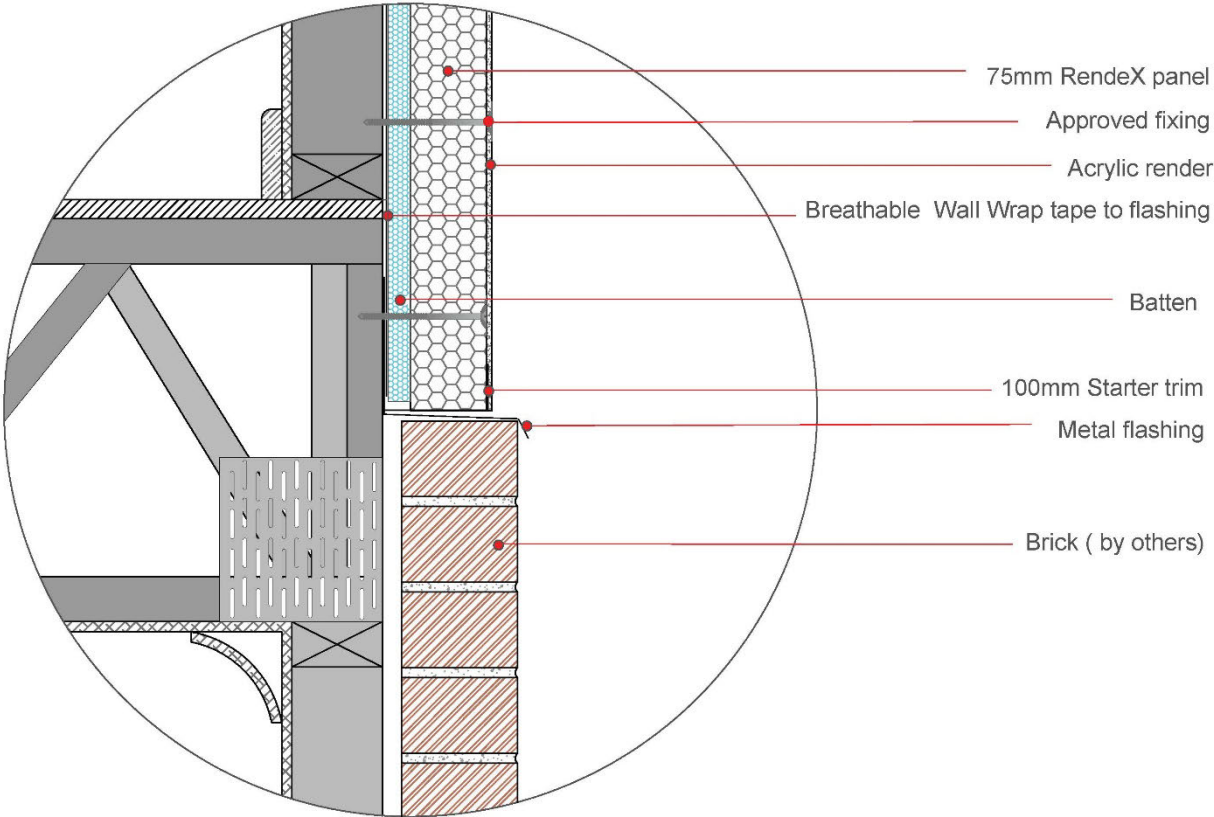

DISSIMILAR SUBSTRATE HORIZONTAL MOVEMENT JOINT DETAIL SYSTEM 2

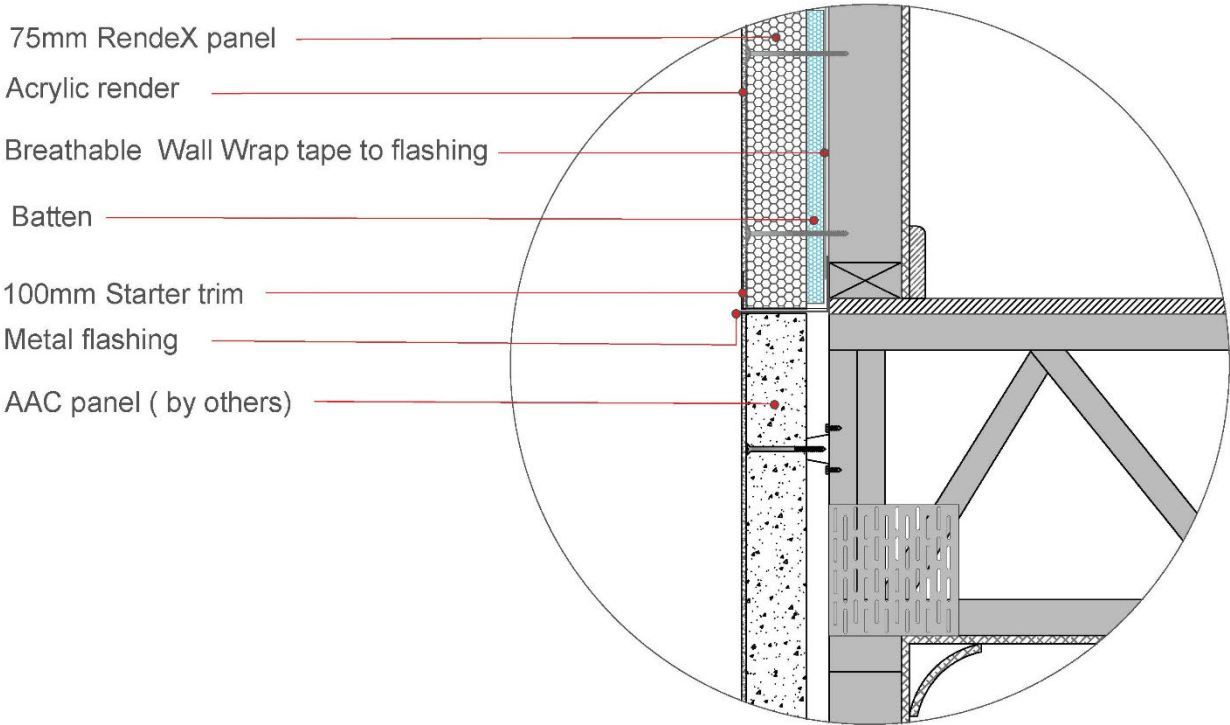

VERTICAL MOVEMENT JOINT DETAIL SYSTEM 2

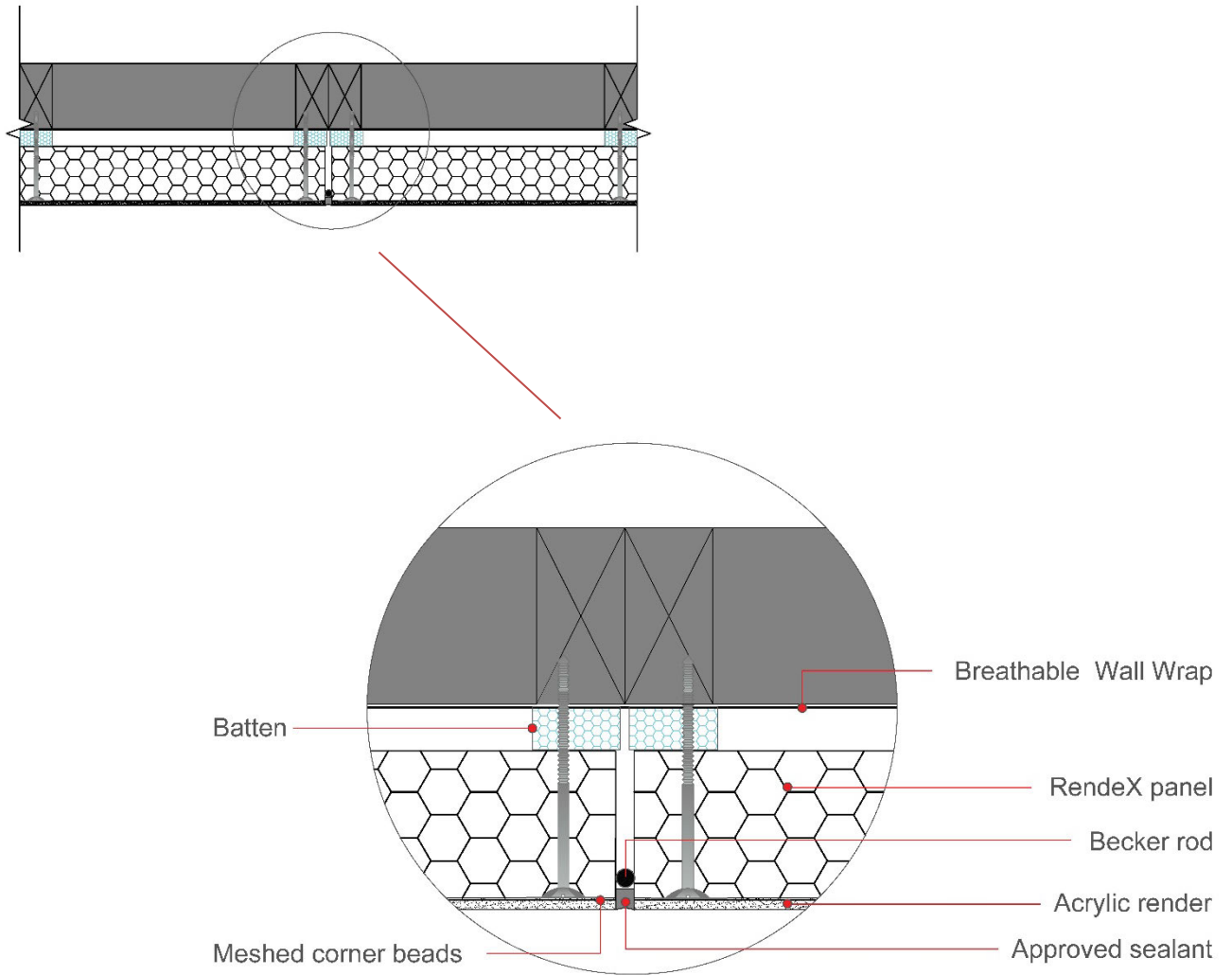

INTERNAL AND EXTERNAL CORNER DETAIL
SYSTEM 2

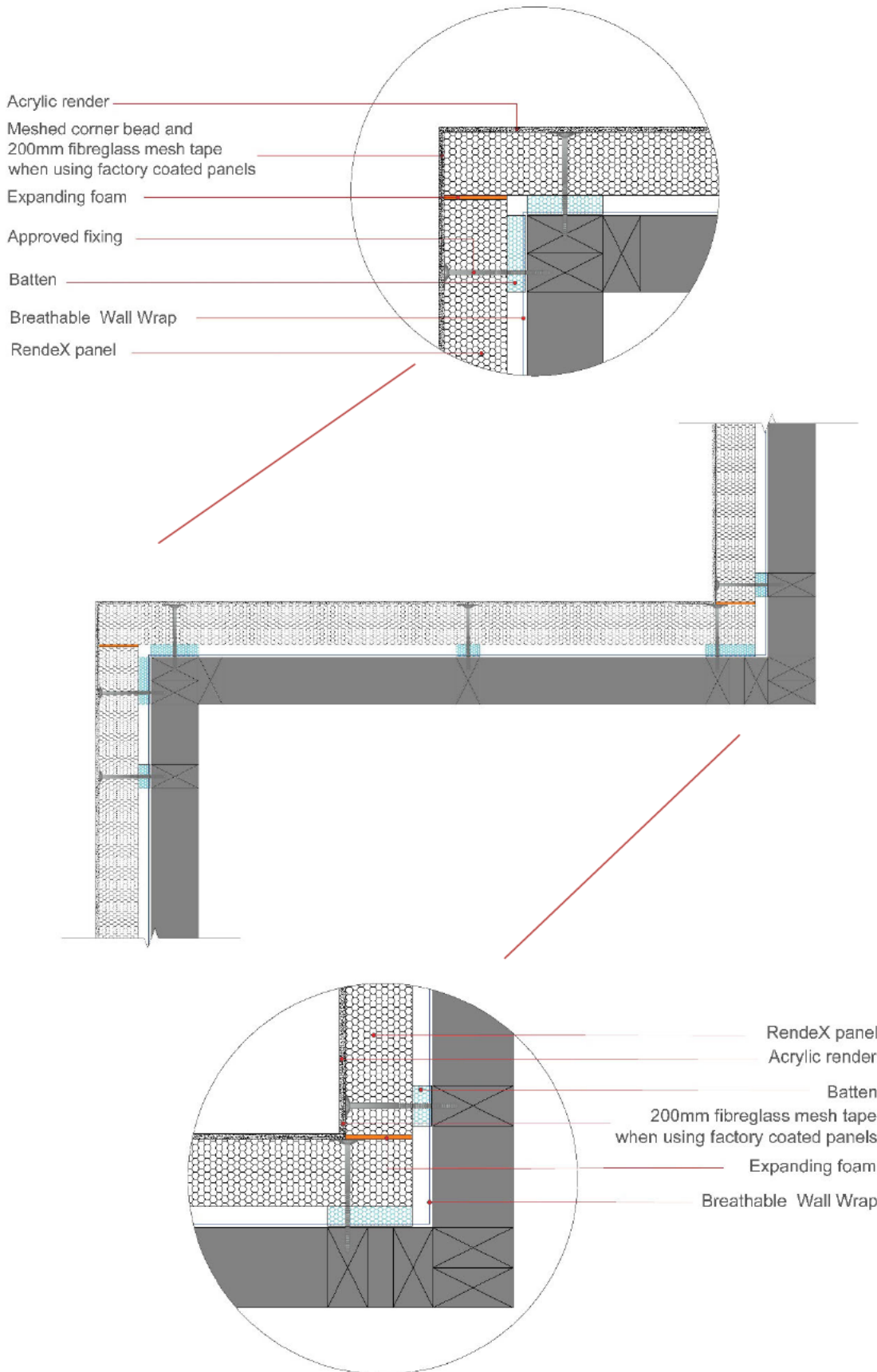

GROUND SLAB DETAIL WITH STARTER TRIM AND STRTER PANEL | SYSTEM 2

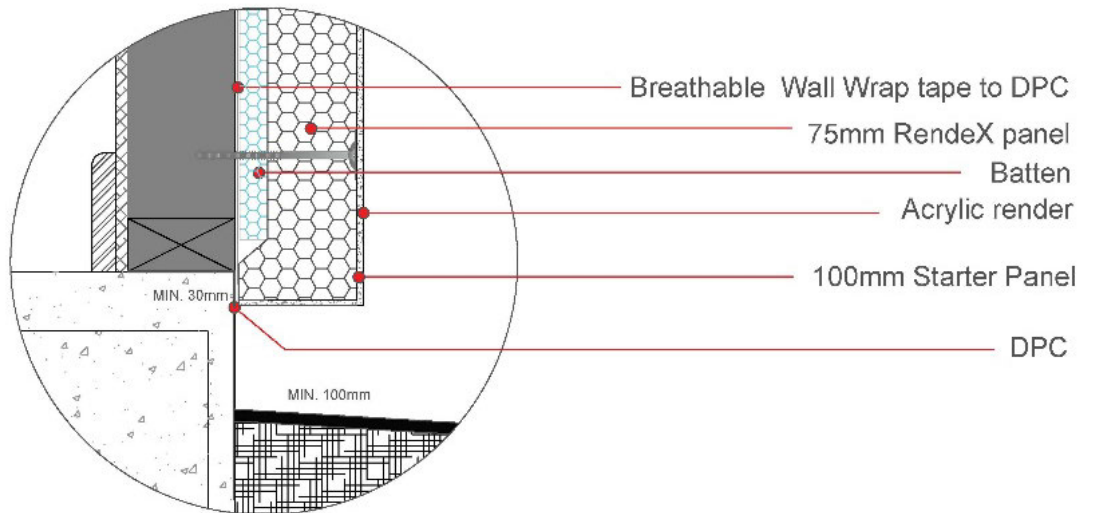
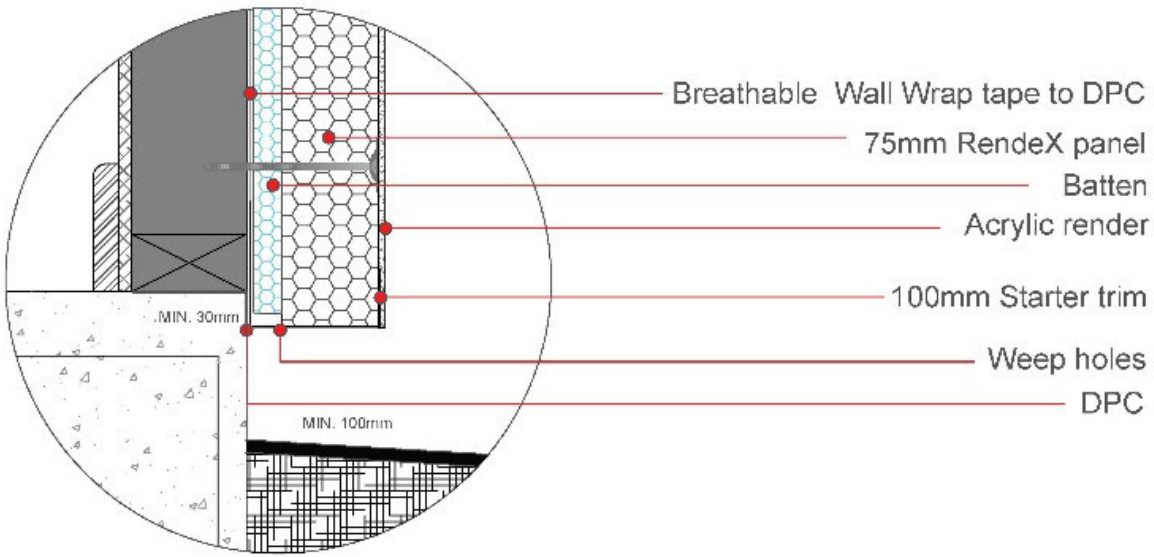

DOWNPIPE FIXING DETAIL | SYSTEM 2

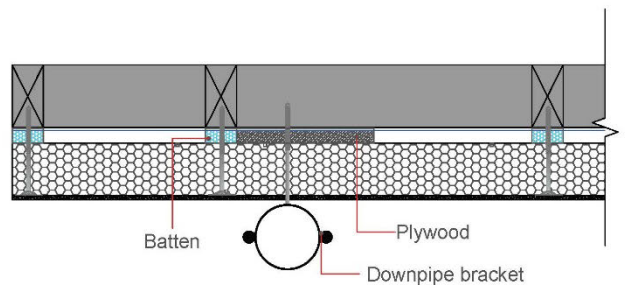
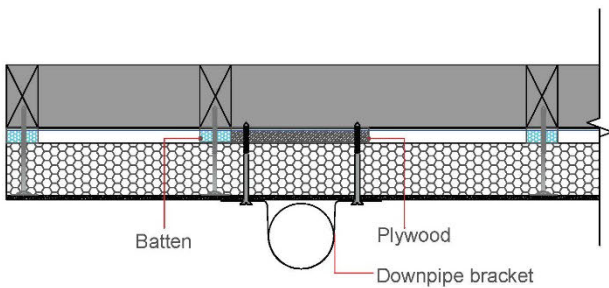

PENETRATION DETAIL | SYSTEM 2

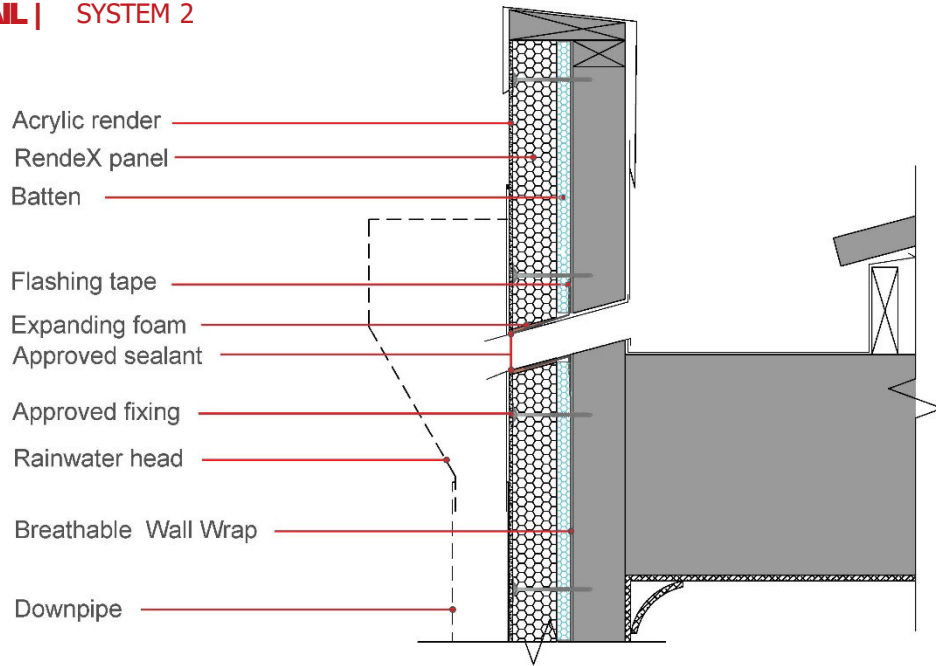

PARAPET/BALUSTRADE WITH SADDLE FLASHING SYSTEM 2

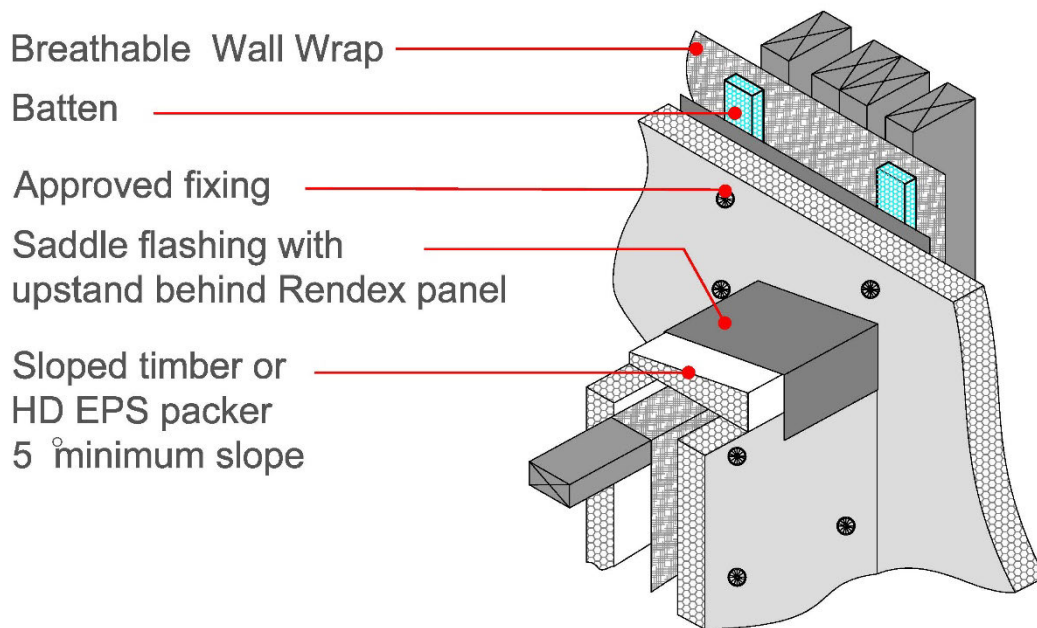



INSTALLATION DETAILS | **SYSTEM 3**

Horizontal RendeX® Panel fixed to steel or timber studs

FIXING LOCATIONS

Fixing and stud locations: Horizontal Rendex® panels fixed to steel or timber studs.

★ Indicates additional studs to provide required support.

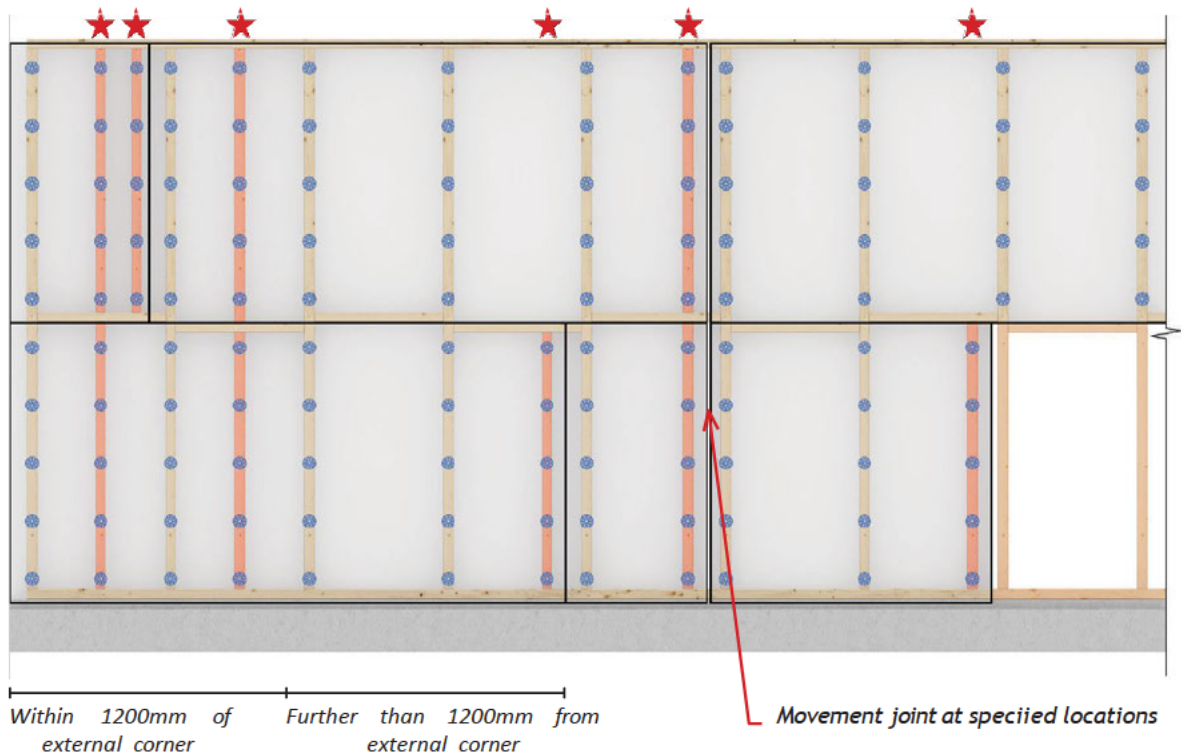

Fixings must not be placed less than 30mm or more than 150mm from the edge or end of a panel.

STEP BY STEP

RendeX® Factory Coated Panels

STEP 1 | Install DPC (by others)

STEP 2 | Install Breathable Wall Wrap



STEP 3 | Cut panel to size

STEP 4 | Fix panel with screws and washers

STEP 5 | Fill gaps between the panels with expanding foam

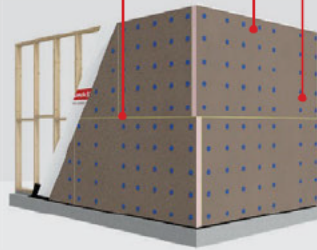

STEP 6 | Install iberglass mesh tape to joints and corners
Apply extra mesh tape to external corner

STEP 7 | Patch with patching compound

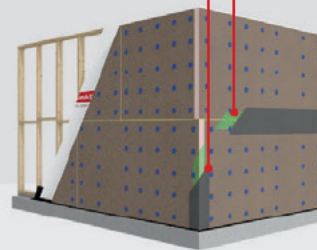

STEP 8 | Apply RendeX® Basecoat acrylic render to manuf. specs

STEP 9 | RendeX® Texture

STEP 10 | Acrylic paint membrane

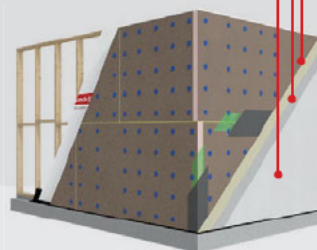

RendeX® Applicator Coated Panels

STEP 1 | Install DPC (by others)

STEP 2 | Install Breathable Wall Wrap



STEP 3 | Cut raw EPS board to size

STEP 4 | Fix board with screws and washers

STEP 5 | Fill gaps between the boards with expanding foam

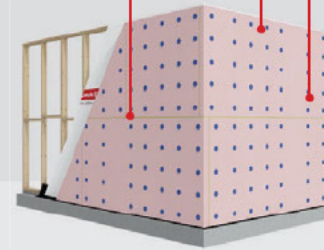

STEP 6 | Render with RendeX® Basecoat acrylic render

STEP 7 | Embed iberglass mesh to whole surface
Apply extra mesh to external corner

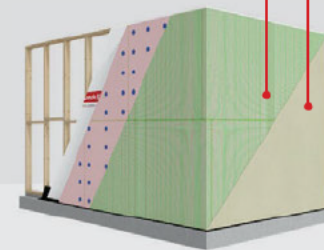

STEP 8 | Apply additional coat of RendeX® Basecoat acrylic render to manuf. specs

STEP 9 | RendeX® Texture

STEP 10 | Acrylic paint membrane



GENERAL ARRANGEMENT | SYSTEM 3

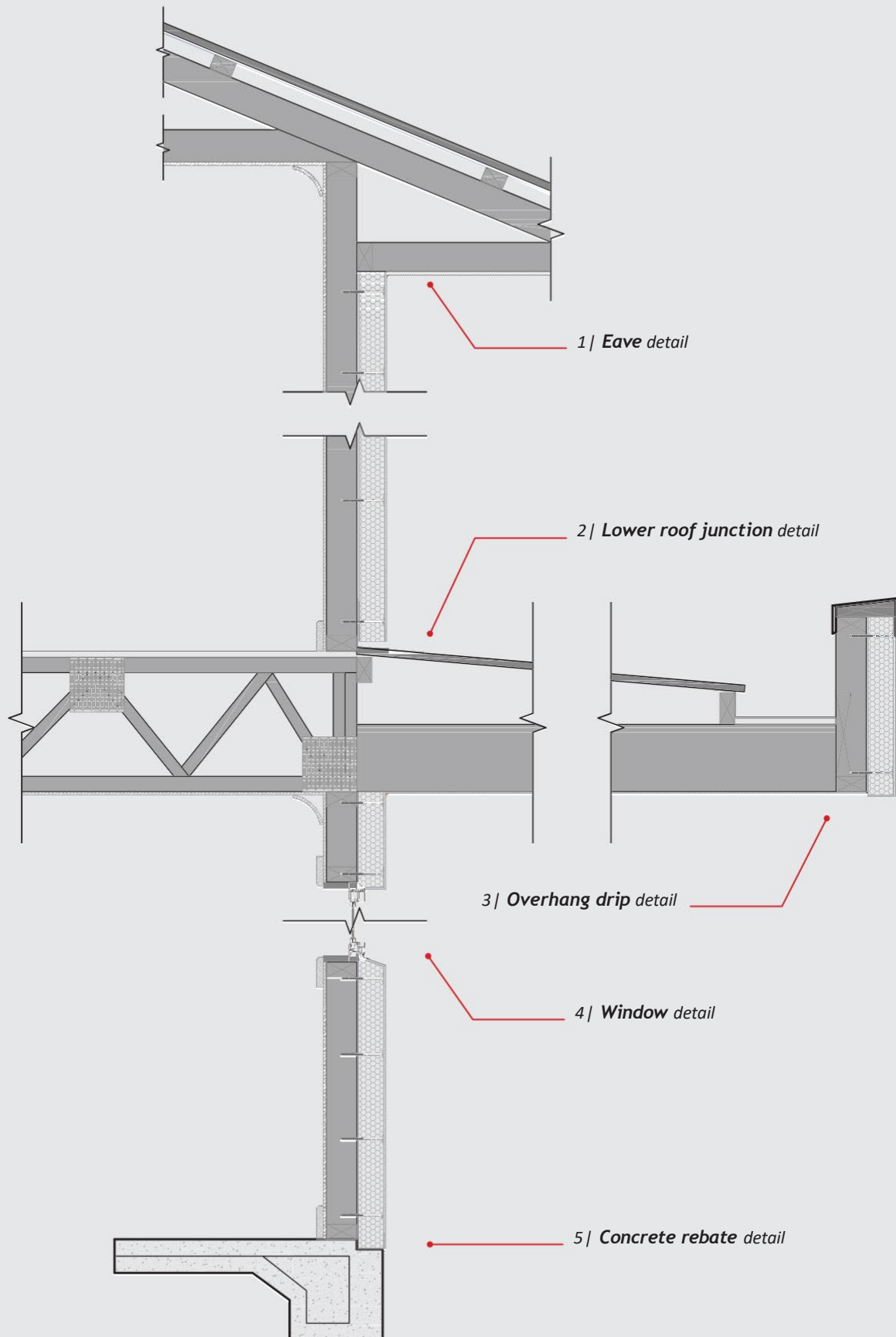

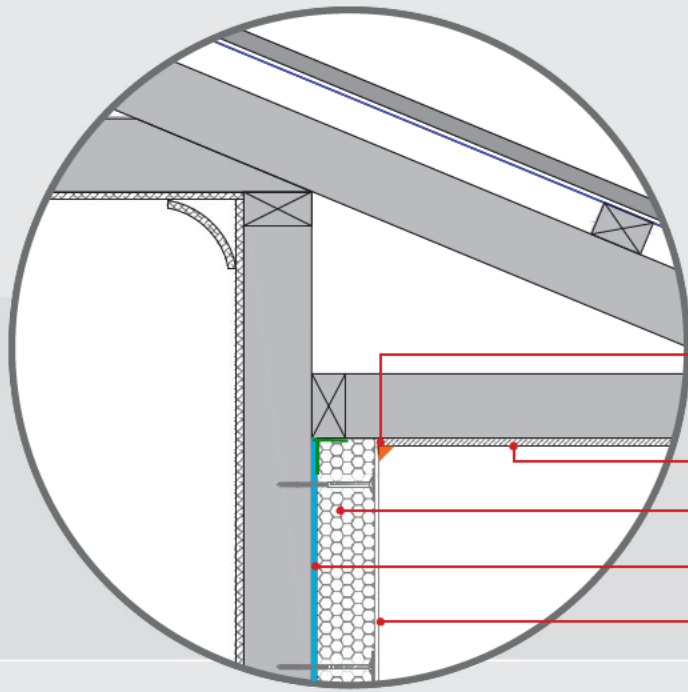

**EAVE DETAIL | OPTION A
SYSTEM 3**

Approved sealant

Eave lining (by others)

RendeX® panel

Breathable Wall Wrap tape to frame

Acrylic render

**EAVE DETAIL | OPTION B
SYSTEM 3**

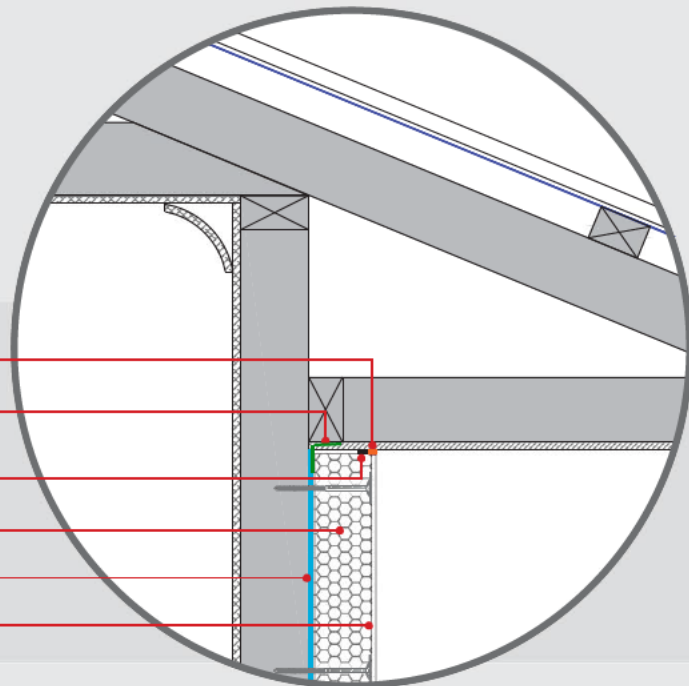

Approved sealant

Eave lining (by others)

Backing rod

RendeX® Panel

Breathable Wall Wrap tape to frame

Acrylic render

LOWER ROOF JUNCTION WITH STARTER TRIM DETAIL SYSTEM 3

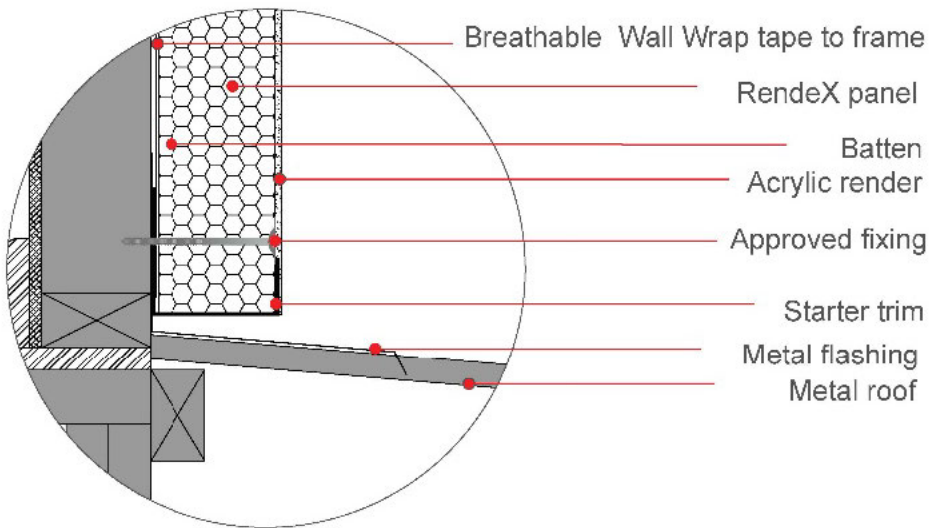

LOWER ROOF JUNCTION WITH STARTER PANEL DETAIL SYSTEM 3

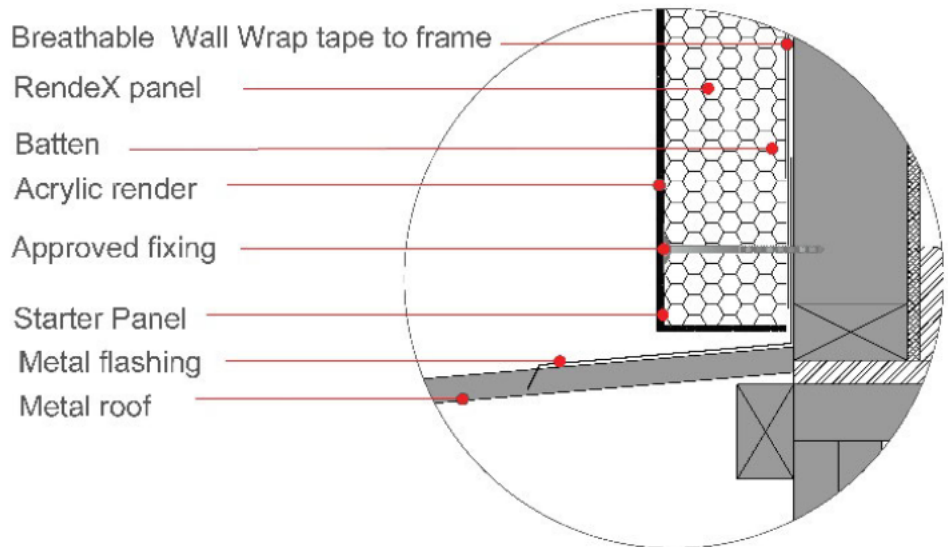

WINDOW DETAIL SYSTEM 3

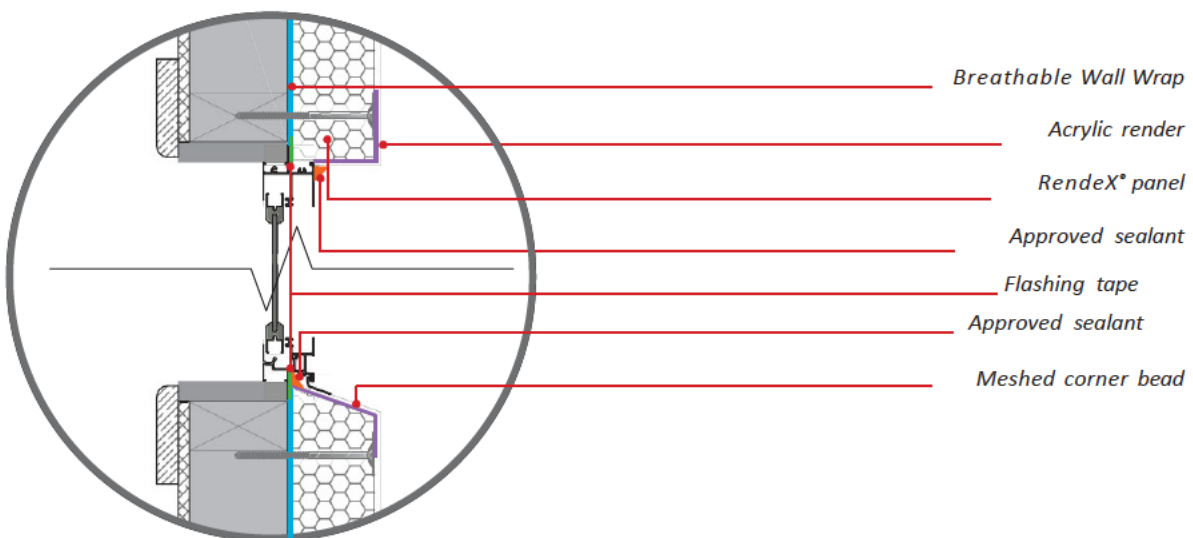

CONCRETE REBATE WITH STARTER TRIM DETAIL SYSTEM 3

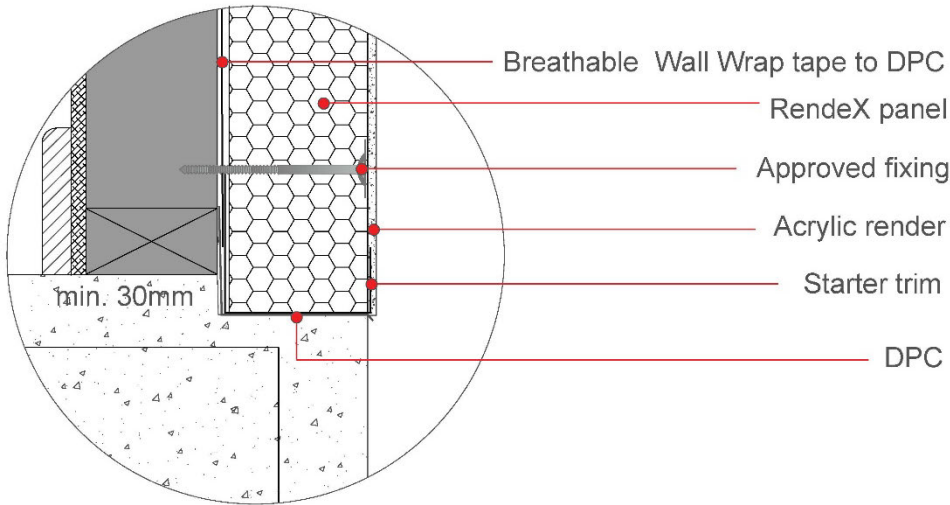

CONCRETE REBATE WITH STARTER PANEL DETAIL SYSTEM 3

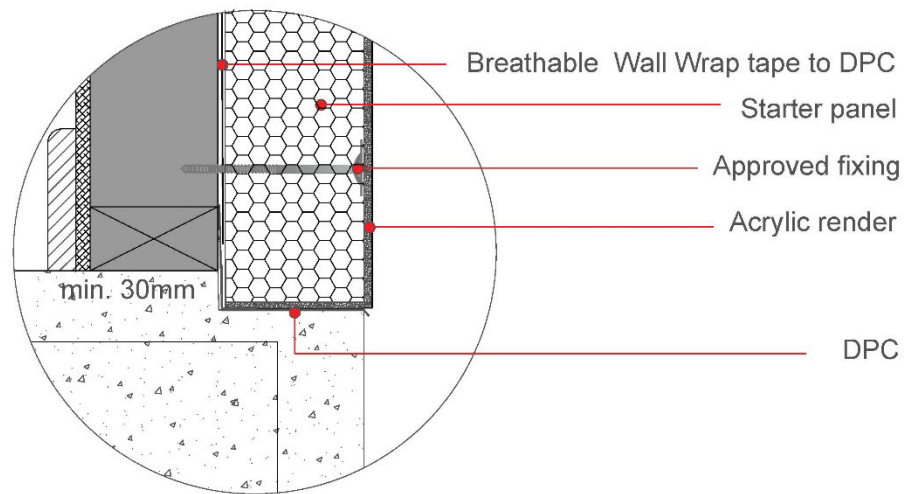

OVERHANG DETAIL SYSTEM 3

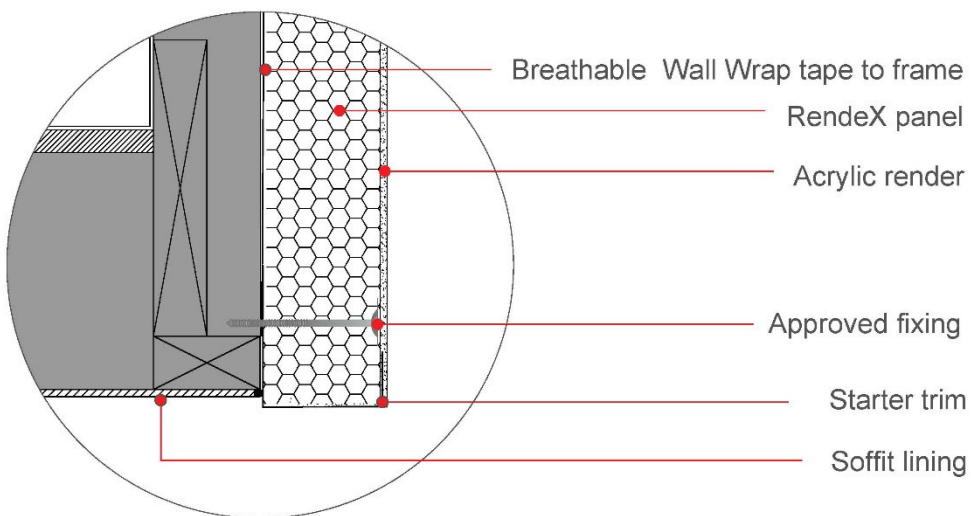

RendeX AND BRICK VENEER DETAIL SYSTEM 3

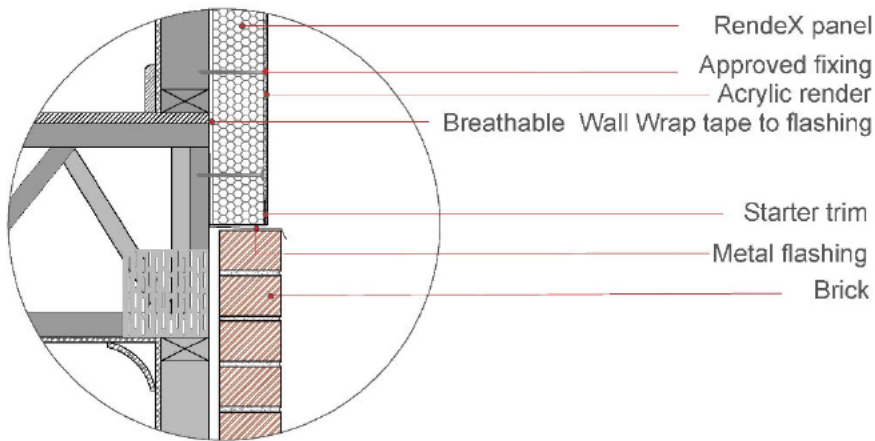

RendeX AND AAC PANEL DETAIL SYSTEM 3

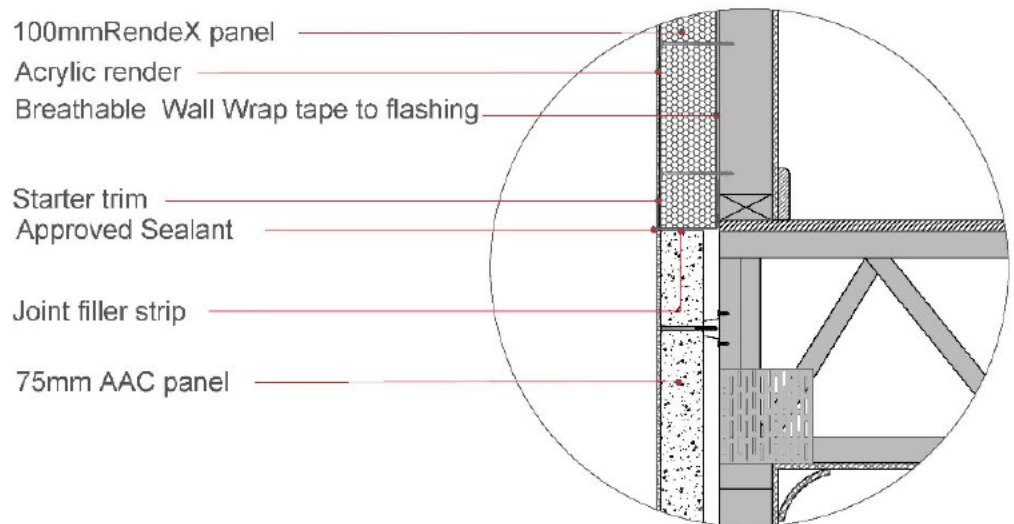

VERTICAL MOVEMENT JOINT DETAIL SYSTEM 3

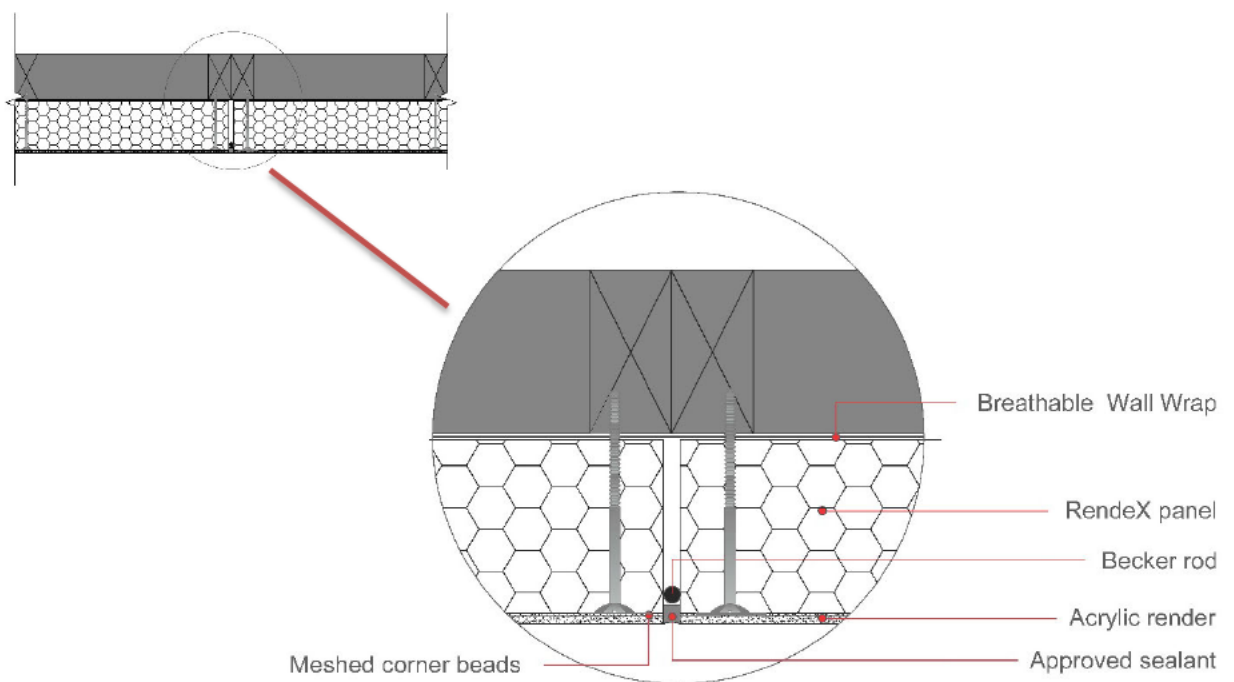

INTERNAL AND EXTERNAL CORNER DETAIL SYSTEM 3

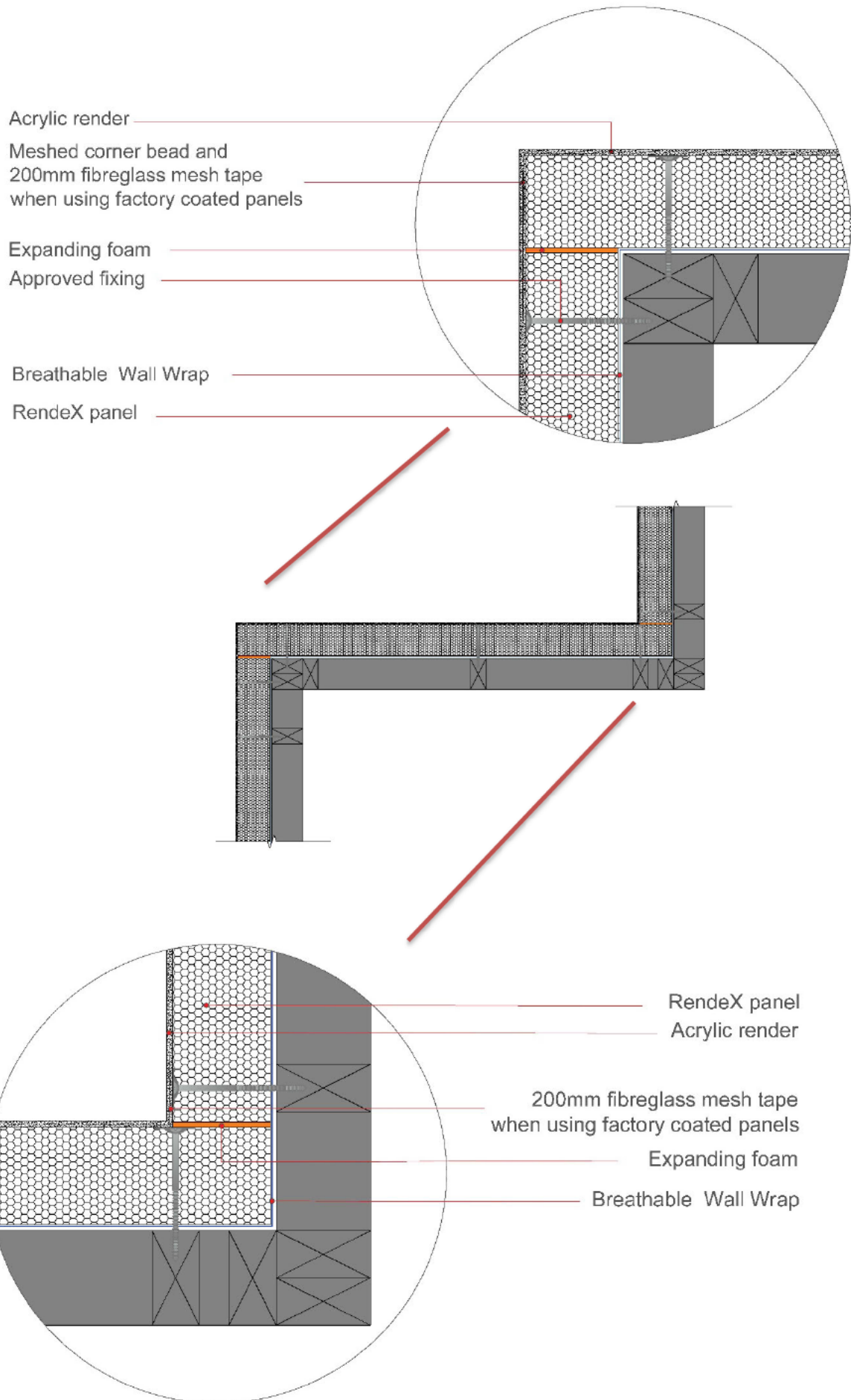

GROUND SLAB WITH STARTER PANEL DETAIL SYSTEM 3

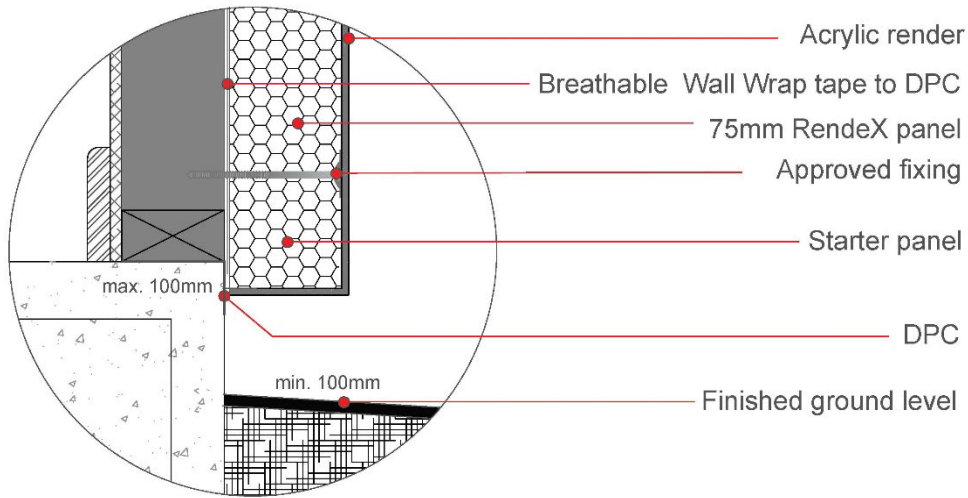

GROUND SLAB WITH STARTER TRIM DETAIL SYSTEM 3

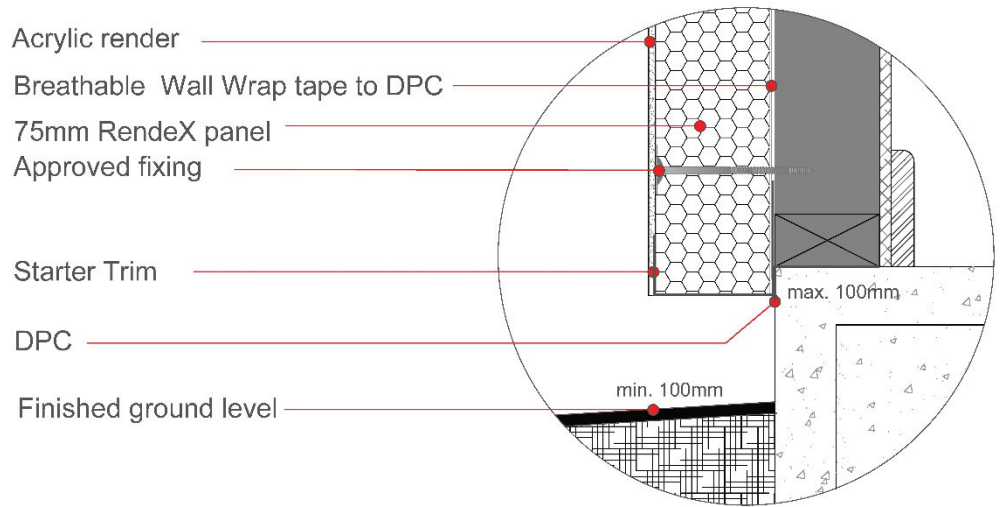

DOWNPIPE FIXING DETAIL SYSTEM 3

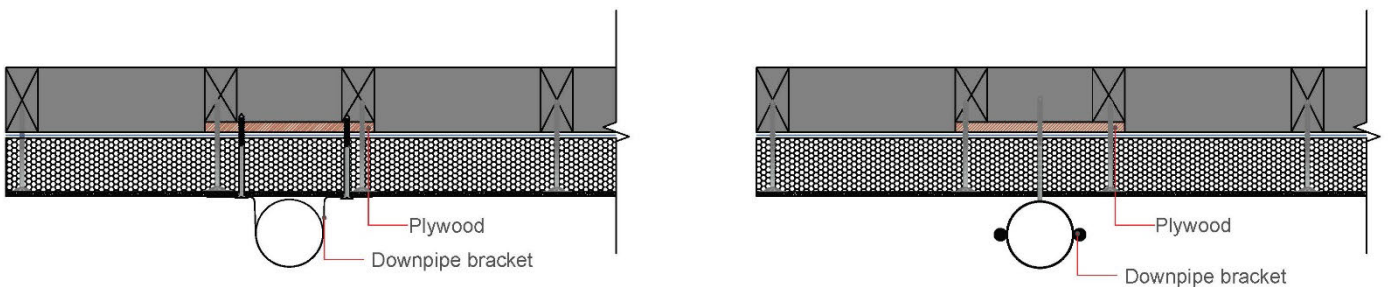

PARAPET/BALUSTRADE WITH SADDLE FLASHING DETAIL SYSTEM 3

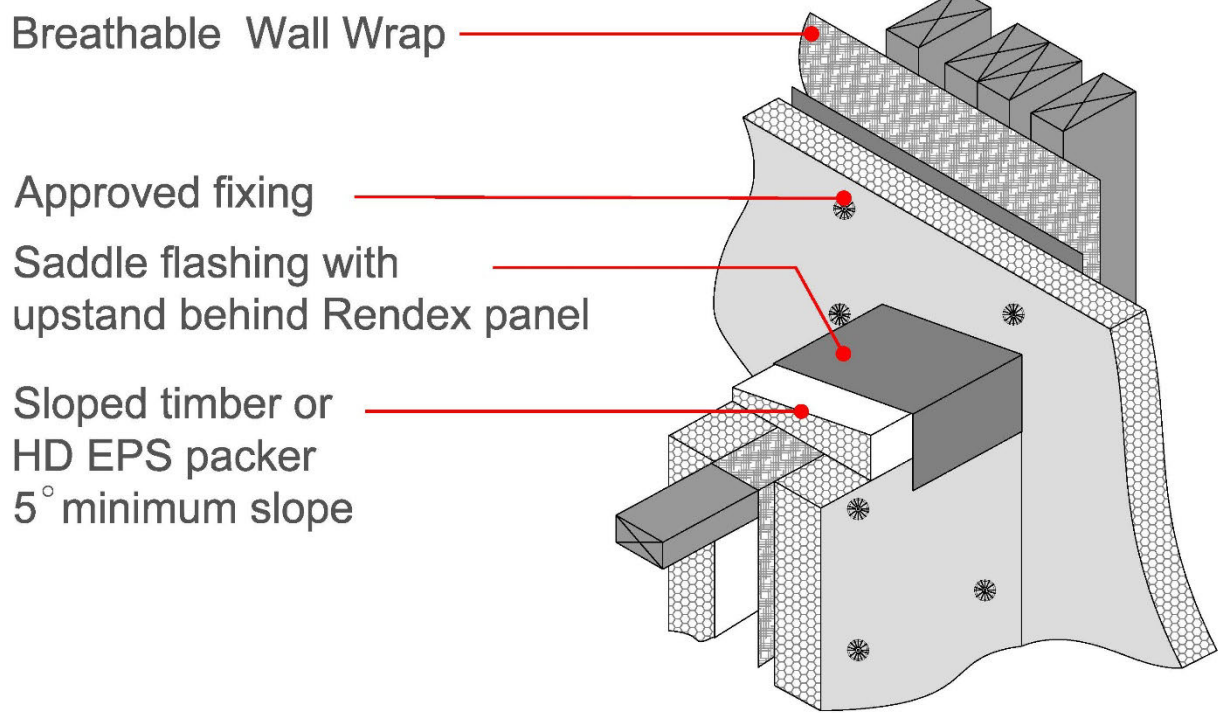

PENETRATION DETAIL SYSTEM 3

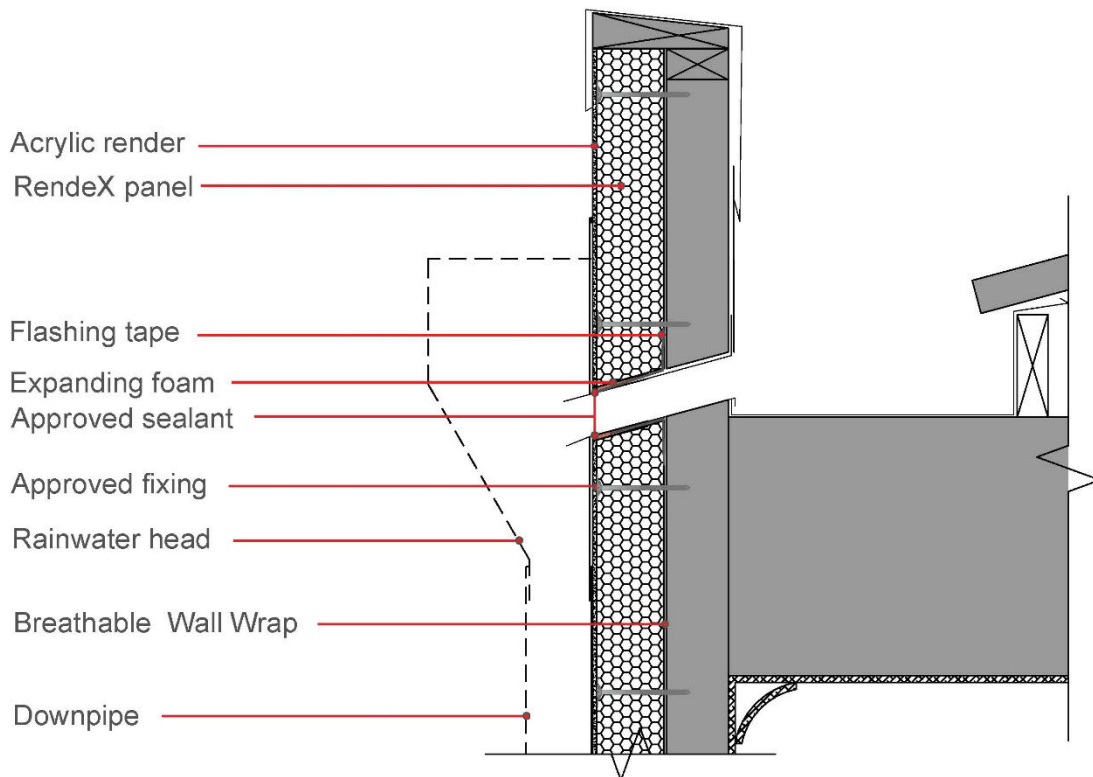

11. COMMON DETAILS

MESHING OF RENDEX PANELS AT WINDOW OPENINGS | SYSTEMS 1, 2 AND 3

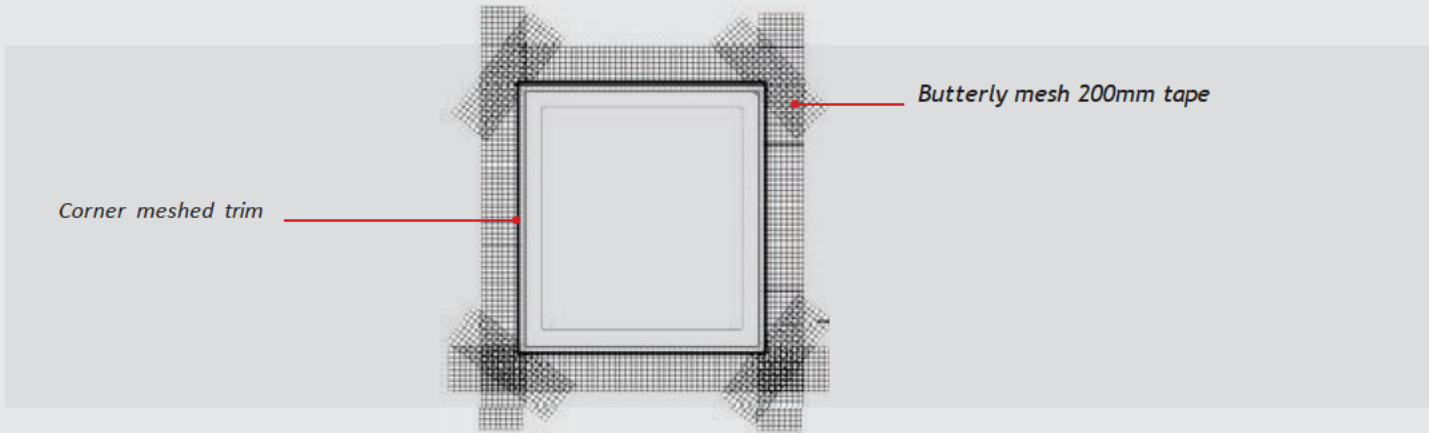

PARAPET AND BOX GUTTER DETAIL | SYSTEMS 1, 2 AND 3

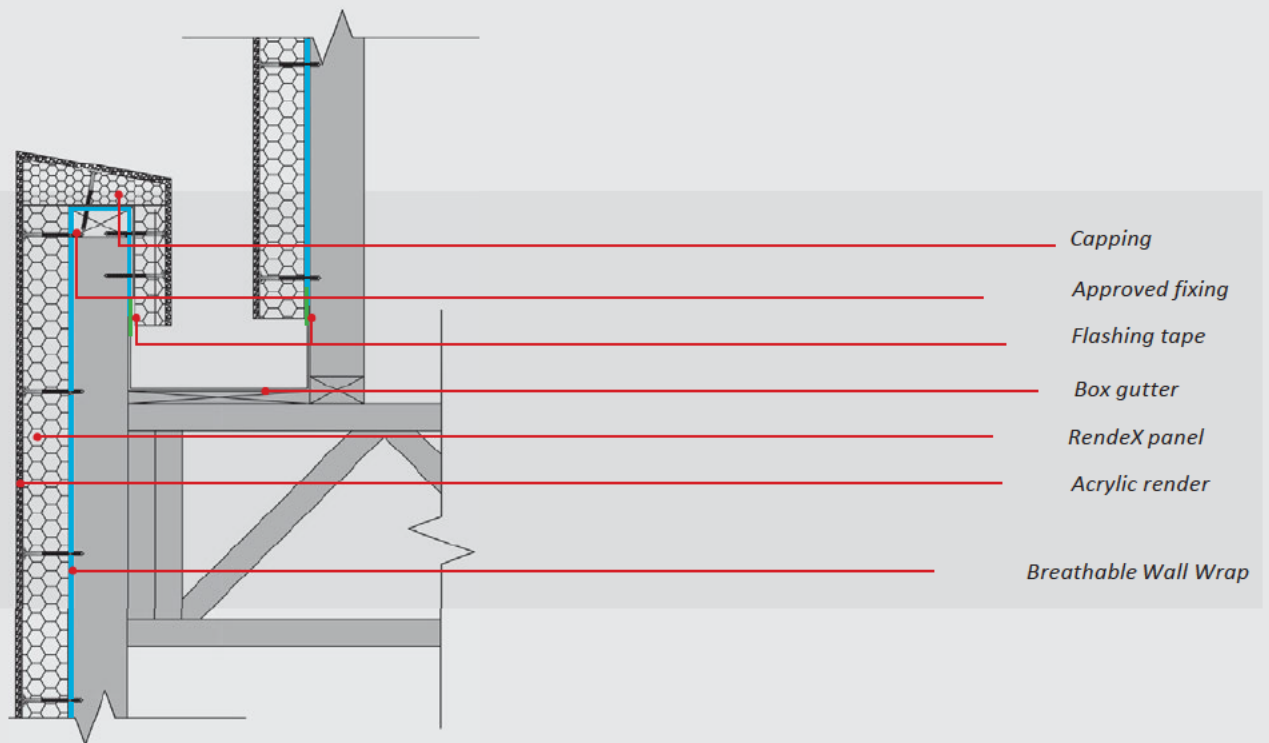

1 2 . CERTIFICATION OF PERFORMANCE SOLUTION

The RendeX® External Cladding System is suitable as a Performance Solution complying with the following Parts of the National Construction Code (NCC) - Building Code of Australia (BCA) 2022(Amdt.2.)

Volume One B1P1 (1), (2) (a), (b) & (c) and Volume Two H1P1 (1), (2) (a), (b) & (c) in respect of structural performance of external walls designed and constructed in accordance with this Manual, where the Ultimate Limit State net pressure does not exceed $\pm 3.01\text{kPa}$ (non-cyclonic); calculated using AS/NZS 1170.2 or AS 4055. This includes AS4055 Wind Classifications N1, N2, N3 and N4 (and excludes AS4055 Wind Classifications N5, N6, C1, C2, C3 and C4).

Volume One F3P1 and Volume Two H2P2 in respect of weatherproofing for walls, designed and constructed in accordance with this Manual, where the Serviceability Limit State net wind pressure does not exceed $+0.82 \text{ kPa} / -1.23\text{kPa}$ (non-cyclonic); calculated using AS/ NZS 1170.2 or AS 4055. This includes AS4055 Wind Classifications N1, N2, N3 and N4 (and excludes AS4055 Wind Classifications N5, N6, C1, C2, C3 and C4).

SUBJECT TO THE FOLLOWING CONDITIONS

Product selection, and incorporation into the building design, must be made by a person who is conversant with the application and technical aspects of the product, and has ready access to the relevant technical information related to the product use.

Product installation must be carried out by a competent carpenter or other tradesman under the direction of a licensed Builder, both of whom are conversant with the method of product installation, and have access to all relevant technical information on product installation.

BASIS OF CERTIFICATION

This Certification is based on the following test reports:

Laboratory	Report No and Date
Newcastle University	A/564C, Panel and Fixing Strength, 06/2012
Ian Bennie and Associates	2019-051-S1 Weatherproofing, test date 08/05/19
Ian Bennie and Associates	2019-051-S2 ULT, test date 08/05/19
Ian Bennie and Associates	2019-051-S3 ULT, test date 08/05/19
Ian Bennie and Associates	2019-051-S4 ULT, test date 08/05/19
Ian Bennie and Associates	2019-051-S5 ULT, test date 08/05/19
Ian Bennie and Associates	2019-051-S6 ULT, test date 08/05/19
Ian Bennie and Associates	2020-057-S1, test date 28/05/20

LIMITATIONS

This certification does not deal with fire resistance or fire hazard properties.

The RendeX® External Cladding System is designed to be used as an external cladding in non-fire rated wall applications.

This certification does not apply to AS4055 Wind Classifications N5, N6, C1, C2, C3 or C4.

This certification does not deal with material safety and should be considered in conjunction with a suitable Safety Data Sheet, which considers all aspects of safety including threats to respiration and the possibility of electrocution.

The test reports listed above provide the basis for an NCC and BCA compliance appraisal of the RendeX® External Cladding System and do not deal with the quality assurance aspects of the manufacturing, construction and installation processes.

13. WARRANTY

Prestige Wall Systems Pty Ltd (PWS) as the manufacturer of the RendeX® Panel provides a seven year warranty as follows:

- PWS provides the warranty from date of purchase for replacement of defective product only.
- PWS will be in no circumstances liable for any loss or damage (including consequential loss), whether direct or in direct to persons or property.
- PWS will not be responsible and/ or liable to any person in any way for incorrect fixing, installing, finishing and rendering by any person.

Warranty is null and void if product is not installed in accordance with guidelines given and set by this Manual.

*Dark colours on the RendeX® System are not warranted and void all warranties as due to potential extensive heat absorption.

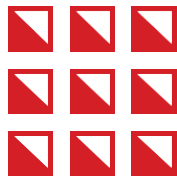

www.rendex.com.au

ADDRESS

24 Humphries Tce,
Kilkenny SA 5009

CONTACT

08 8244 1999
sales@prestigewallsystems.com.au