

OzHemp Tradical®

# HEMPCRETE INSTALLATION MANUAL



OzHemp

W: [www.ozhemp.com.au](http://www.ozhemp.com.au)

E: [info@ozhemp.com.au](mailto:info@ozhemp.com.au)



# OzHemp



## **Tradical® Hempcretes, materials that set the standard**

Our hempcretes have been developed in collaboration with professionals to meet their expectations and have been used on a wide range of construction sites for the past ten years with unrivalled functional reliability and no distress observed to date.

### **Reliability**

The vast majority of experiments relating to hempcretes have been - and still are - conducted with Tradical® Hempcretes. The trust that research institutions place in our products allows us to benefit from substantive knowledge acquired from experimental constructions and numerous development programmes.

### **Ease-of-use**

The ease-of-use, performance, and reliability that have contributed to the reputation of Tradical® Hempcretes are a result of the components' qualification and of the stability of their characteristics. The consistency of the Hemp/Binder blend is what enables us to ensure they are safe to use.

### **Environmental qualities**

Beyond their technical performance, reliability, and conformity with the construction regulations in force, Tradical® Hempcretes also meet other requirements that have become just as indispensable; availability of renewable materials, ability to store CO<sup>2</sup> in the long term, energy efficiency, and non-toxicity are decisive factors in choosing materials today.

## **Codemark Certified against Australian National Construction Codes (NCC) 2022**

OzHemp's Tradical® building products are CodeMark certified and comply with NCC 2022 construction requirements, under the specific limitations and conditions outlined in the CodeMark certificate.

This Certificate of Conformity confirms that the relevant requirements of the Building Code of Australia (BCA) have been met. It assures homeowners, builders, architects, designers, and building certifiers that Tradical® Hempcrete products meet the necessary compliance standards for hempcrete construction.



# OzHemp Tradical®

## Hempcrete Installation Manual

### 1. Introduction

---

The building material called Hempcrete is an insulation material made of Hemp hurd or shiv, water and a lime based binder.

This document is based upon and complies with the French professional rules for installation of Hempcrete and evolved out of more than 25 years of experience in the industry in Europe. The manual is especially designed for TRADICAL® products and Building Grade Hemp hurd or shiv.

It is necessary to have completed a training course and to fully understand the methods used to install Hempcrete in order to keep the building standards at a high level and assure the longevity of the building and the safety of the occupants. This is then related to the insurance one can take out for the building wherein Hempcrete is installed. As in the installation of any other building material, it comes down to the responsibility of the installer and the builder to have gained experience, knowledge of building techniques and codes.

It is a condition of the product warranty that both the installer and the builder complete proper training and obtain accreditation. This ensures the quality of the installation and compliance with the Building Code of Australia (BCA) in accordance with NCC 2022 requirements.

All elements of building work need to comply with the current BCA standards and requirements. This document is to define the basic characteristics and rules when using Hempcrete in constructions.



### More than 20 years of research, trials and achievements

#### Perfectly cohesive

All Tradical® Hempcrete performance characteristics result from the development of hemp+lime blends (Approved Building Grade Hemp Shiv + Tradical® PF 70/ Thermo or Tradical® PF 80 M/Bâtir), that maintain perfect material cohesiveness while enabling mix proportions to be adjusted to adapt characteristics to uses.

#### R&D

Tradical® Hempcrettes have been developed with professionals to meet their specifications and stem from the complementary expertise of partner laboratories and BCB, centre of expertise for the Lhoist Group—one of the world's leading air lime specialists.

#### A benchmark blend

The excellent properties of Tradical® Hempcrettes have made it a benchmark material used by many laboratories (ENTPE, CEBTP, UCL, CSTB, etc.) in studies conducted as part of R&D as well as in experimental construction projects.

#### Optimisation

Their use for more than twenty years on a large number of construction sites by trained professionals has enabled us to optimise their performance and confirm that they function properly.

## 2. Contents

---

<b>1. Introduction</b> .....	Page 1
<b>2. Contents</b> .....	Page 2
<b>3. Compliance</b> .....	Page 4
<b>4. Materials to Make Hempcrete</b> .....	Page 4
<b>5. Introducing Hempcrete Zero - Carbon Building</b> .....	Page 6
<b>6. Benefits of Hempcrete Construction</b> .....	Page 7
<b>7. The Ingredients</b> .....	Page 10
7.a. Hemp	
7.b. TRADICAL® Lime Binder	
7.c. Water	
<b>8. Protection / Safety / Hazards / First Aid</b> .....	Page 13
8.a. Working on Ladders and Scaffolding	
8.b. Eye Protection	
8.c. Skin Protection	
8.d. Respiratory Protection	
8.e. Environmental Protection	
8.f. First Aid	
<b>9. Physical Characteristics of the Material</b> .....	Page 15
<b>10. Mixing</b> .....	Page 16
10.a. Mixing Hempcrete	
10.b. Reusing Hempcrete	
<b>11. Mixing Method</b> .....	Page 17
11.a. The Pan Mixer	
11.b. Standard Barrow Mixer	
11.c. Recommended Working Conditions	
11.d. Steps of Mixing	
<b>12. Get Set Up for the Job</b> .....	Page 18
12.a. Things to Consider and Plan	
<b>13. Formwork</b> .....	Page 19
13.a. Permanent Formwork	
i) Magnesium Board	
ii) Bamboo / Reed Mats	
iii) Perforated Building Paper and Glass Fibre Mesh	
13.b. Temporary Formwork	



<b>14. Framed Walls</b> .....	Page 21
14.a. Stud Frame	
14.b. Embedding Frame Elements with Hempcrete	
14.c. Bracing and Tie Down	
14.d. Frame on Slab	
14.e. Frame on Suspended (timber) Floor	
14.f. Bathrooms and Retaining Walls	
14.g. Electrical	
14.h. Plumbing	
14.i. Termite Proof	
14.j. Timber Post and Beam Construction	
14.k. Steel Frames	
14.l. Concrete Post and Beam Construction	
14.m. Window and Door Openings	
14.n. Fixing loads to Hempcrete Walls	
<b>15. Creating Hempcrete Walls</b> .....	Page 28
15.a. The Low (standard) Density Wall Mix	
15.b. How to - Install Hempcrete Wall Insulation	
15.c. Making of Day Joint	
15.d. How to - Replace / Repair of Hempcrete	
15.e. Casting an Internal Hemp Wall into an External Hemp Wall	
<b>16. Roofs and Floors</b> .....	Page 31
16.a. The Roof Mix	
16.b. How to - Install Hempcrete Roof Insulation	
16.c. The Insulating Floor Mix	
16.c. How to - Install Insulating Hempcrete Floor (between joists)	
<b>17. Drying of Hempcrete</b> .....	Page 36
17.a. Drying	
17.b. Best Practice for Drying	
17.c. Curing or Setting	
17.d. Carbonisation	
17.e. Not Proper Drying	
<b>18. Wall Cladding and Rendering</b> .....	Page 37
18.a. Cladding Materials of External Walls	
18.b. Cladding Materials of Internal Walls	
<b>19. Hempcrete Render</b> .....	Page 38
19.a. The Hempcrete Render Mix	
19.b. How to - Install Hempcrete Render by trowelling - up to 50 mm	
19.c. How to - Install Hemp Insulation (Render) with Formwork - from 50 mm to 200 mm	
19.d. Hygrothermal Hemp Render	
19.e. Lime Render	
<b>20. Render</b> .....	Page 44
20.a. Interior and Exterior Render	
20.b. Aesthetical Render - Finishing Coat	
20.c. How to - Mix Render	
<b>21. Preservation of Hempcrete Walls &amp; Renders</b> .....	Page 45
<b>Mixing Quick Reference Guide</b> .....	Page 46
<b>Contacts</b> .....	Page 48

### 3. Compliance

Hempcrete is used more and more worldwide and now in Australasia in a vast variety of dwellings including prestigious penthouses and villas.

To ensure Hempcrete’s excellent reputation and compliance is maintained, building contractors must provide their clients with the necessary guarantees to meet mandatory house insurance and legal obligations.

Hempcrete is a good alternative to standard insulation materials.

This professional’s installation manual for Hempcrete is the document supporting the training.

Products supplied by OzHemp are to be installed to the standards of this manual by tradespeople and owner builder license holders who have successfully completed the OzHemp training. This is a condition of the BCA certification of Hempcrete with OzHemp and its product warranty.



Codemark Certification Badge

**Tradical® Hempcrete is the first hempcrete to comply with:**

**BCA** (Building Code of Australia) As per NCC 2022 Volumes 1 and 2 requirements

**BBA** (British Board of Agrément)

**C2P** (French Professional Rules for the construction of Hempcrete Structures)

With compliance to NCC 2022, homeowners, architects, specifiers, and builders can rest assured that Tradical® Hempcrete products meet all requirements for hempcrete construction. This compliance ensures that users will enjoy the same guarantees and warranties as those associated with traditional building materials.

### 4. Materials to Make Hempcrete

The following materials are supplied by OzHemp, and therefore these products only are included in the conformity and certification of the product:

- The Binder; Tradical®PF70 / Tradical® Thermo
- The Render Binder; Tradical®PF80 / Tradical® Batir / Tradical® Decor
- The Hemp Shiv; Hempflax® / Chanvribat® Building Grade Hemp / Kanabat® Building Grade Hemp

These products are tested and approved under government regulations and meet the following Standards:

- (a) Binder and the Hemp compatibility and
- (b) The Binders and its mix proportions are specifically formulated, developed and tested in laboratories to create certain performances in conjunction with the aggregates. Use of other materials may be subject to failure and will null and void materials warranty given by OzHemp.



Tradical® Binder PF70



Tradical® Binder Thermo



Tradical® Render Batir



Tradical® Render Décor



Tradical® Render PF80



Chanvribat® Building Hemp Shiv



Hempflax® Building Grade Hemp Shiv



Kanabat® Building Hemp Shiv



## An inseparable pair

The binders used and the characteristics of the hemp aggregate (particle size distribution, humidity, etc.) have a direct influence on the performance of hemp mortars and hempcretes.

You must use quality approved building grade hemp shiv combined with either Tradical® PF 70/Tradical® Thermo or Tradical® PF 80 M/Tradical® Bâtir to achieve the expected results and benefit from product warranties.

## Unique qualities

### Performance and technical benefits

- Light and ultralight Hempcretes
- Elasticity
- Porosity, permeability to water vapour
- Sound absorption

### Energy efficiency

The thermal characteristics of Tradical® Hempcretes enables them to meet the most stringent requirements for low-energy buildings.

- They use less grey energy, resulting in buildings with a particularly high-performance overall energy balance.

- They improve the hygrothermal behavior and surface temperature of walls.
- They decrease energy consumption in winter and summer alike, both for new buildings and renovations.

### Environmental and health qualities

- Agricultural production without phytosanitary products
- Minimal depletion of natural resources
- Carbon storage
- Indoor air quality: no VOCs or known toxic elements

## 5. Introducing Hempcrete- 'ZERO-carbon' Building

Constructing buildings that have no overall 'greenhouse' impact is a widely-accepted objective today.

Improving energy efficiency contributes to this goal, but it requires an increase in the quantities of materials used to achieve better wall insulation, which generally leads to greater quantities of GHG emissions in the manufacture of these materials.

Unlike other materials, Tradical® Hempcrete not only optimises the thermal transmission factor, but is able to curb such significant impacts as the consumption of grey energy or the depletion of natural resources and improve their greenhouse effect performance by storing even more CO<sup>2</sup> thus allowing this objective to be achieved. See table below.

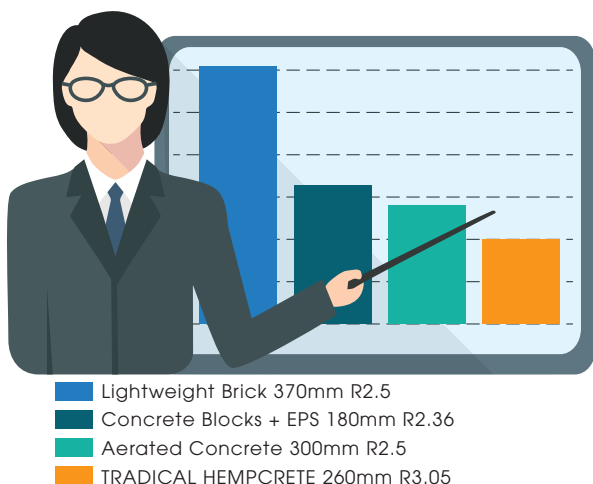

### ENERGY TO MANUFACTURE BUILDING MATERIALS

260mm of Tradical® Hempcrete achieves a thermal transmission factor U of 0.32 W/m<sup>2</sup>.K that is compatible with the thermal regulations (Insulation Values) in France (RT 2005). Compared to other materials with a similar thermal resistance, the energy required to create 1m<sup>2</sup> of wall made of Tradical® Hempcrete is low.

Beyond its energy efficiency and ability to store CO<sup>2</sup>, Hempcrete has numerous environmental and health qualities.

The life cycle analysis of a Hempcrete wall cast in timber framing has shown that Hempcrete has excellent environmental performance ratings in such important aspects as depletion of natural resources, water and air pollution.

Moreover, the lack of a need for plant protection products in agricultural production, mechanical decortication without using any chemical process, the use of mineral binders, the complete absence of any solvents in the formulations, and the systematic rejection of any products that may constitute a toxic hazard, all contribute to guaranteeing the indoor air quality in Hempcrete buildings.

Finally, occupant comfort will also be improved thanks to the ability to achieve excellent thermal comfort with low air temperatures.

Hempcrete is a composite made of Hemp hurd or shiv particles and a lime based binder. The mixture is placed around the structural frame of a building, used as an infill between floor and ceiling cavities or as a render applied to existing walls.

When dried it is regarded as a Hygroscopic, Breathable or Vapour Permeable membrane.

This hygroscopic property should not be hindered with (non-breathable) renders, coatings and surfaces that will prevent the transfer of humidity in and out of the building. The renders used should find approval by OzHemp.

The data published in this document comes from the INIES database (1) and from the life cycle analysis of a Hempcrete wall cast in timber framing, performed by the French National Institute of Agricultural Research (INRA) in accordance with the French standard NF 10.010 (2) at the request and with the support of the French Ministry of Agriculture and of the French Environment and Energy Management Agency (ADEME).

Tradical® Hempcrete has been tested in this analysis.



**(1) INIES:** This is the French reference database on the environmental and sanitary characteristics of construction products. The INIES database is freely accessible online (<http://www.inies.fr>).

**(2) French standard NF 10.010:** This standard governs the life cycle analysis (LCA) of construction products.

According to the NF 10.010 standard, in order to be able to compare environmental impacts, their assessment is based on a functional unit (in this case: 1m<sup>2</sup> of a wall with a similar thermal resistance  $R = 2.36$  to 3m<sup>2</sup>.K/W) and expressed for a year in the life of the structure. The 'greenhouse effect' impact balances GHG emitted and GHG stored.

## 6. Benefits of Hempcrete Construction

---

- » Energy performance
- » ZERO-carbon building
- » Recycle value
- » High Fire protection performance
- » Air tightness
- » Mould free
- » Excellent sound quality
- » Termite resistant
- » Carbon sequestration

### ENERGY PERFORMANCE

The insulation properties of Hempcrete buildings are excellent and rate exceeding R4.1. This is when built to the thickness of 350mm. A 250 mm Hempcrete wall will achieve a Thermal Conductivity factor of 0.085 W/m.K = R2.9. A Hempcrete wall thickness of 300 mm is achieving the R value of 3.5.

The U value (W/m<sup>2</sup>K) is the thermal transmittance of a building element (wall, roof, floor or window). It includes the thermal resistances of all layers (including air cavities) and surfaces resistance at both surfaces of the element. The surfaces resistances account for both convective and long wave radiation between the element surface and the surroundings.

The U value is the heat flow  $Q$  (W) through the whole area of the element divided by the total area of the element and temperature difference between external and internal environments. It is, therefore, used in building energy calculations i.e. SAP, SBEM, (Simplified Building Energy Model) NatHERS, to estimate the total heat loss through the building fabric.

The R value (m<sup>2</sup>K/W) is the thermal resistance of a building element and is the reciprocal of the U value ( $R=1/U$ )



*Thermographic image of a house*

**R-Value** means the thermal resistance ( $m^2K/W$ ) of a component calculated by dividing its thickness by its thermal conductivity.

Compared to other materials with a similar thermal resistance, the grey energy required to build  $1m^2$  of a Hempcrete wall is much lower.

## ZERO-CARBON BUILDING

Constructing buildings that have no overall 'greenhouse' impact is a widely-accepted objective today. Improving energy efficiency contributes to this goal, but it requires an increase in the quantities of materials used to achieve better wall insulation, which generally leads to greater quantities of GHG emissions in the manufacture of these materials.

## RECYCLE VALUE

Hempcrete is 100% made of natural ingredients. The lime based binder and hemp will over time petrify to become stone. Hempcrete is therefore recyclable and a benefit for the soil when returned to the earth.

## HIGH FIRE PROTECTION PERFORMANCE

Fire tests on a 300mm thick Hempcrete wall gave 73 minutes, for structural adequacy, integrity & insulation. This leads to FRL (Fire Resistance Level) of 73 minutes for a 300 mm thick wall. Also, there is very limited smoke development, with no burning droplet/particles. The equivalence rating will only be achieved provided results from the tests are within the certifiable limits of legislation.



*A naked flame on Hempcrete*

Based on the reported performance under full-scale fire exposure and the similarity of exposure and performance criteria between AS 1530.4-2014 and BS EN 1365-1:1999. Therefore, Tradical® Hempcrete wall system shows equivalence to product 'FRL 60/60/60', if tested in accordance with AS 1530.4-2014, will achieve performance compliance for use on loadbearing walls in building construction.

## AIR TIGHTNESS

Hempcrete fills the total wall space to form an interior and exterior wall in one. In the case of ceiling and floor infill, connecting the Hempcrete wall infill does not leave floor and ceiling gaps that will potentially create drafts compromising coolness or warmth to escape or enter the building. This is also called monolithic construction method, it eliminates the standard drafts that occur in building envelopes made of several components e.g. cladding and brick walls. In the optimal situation floors, walls and ceiling infills are all joined to form a fire and draft safe environment.

## MOULD & ALLERGY FREE

Allergens and lung diseases may result from dust, V.O.C.'s and mould related organisms in the living environment. Standard building materials contain V.O.C.'s (volatile organic compounds) and very fine dust particles. These are found in glues, paints, insulation etc. and are not present in Hempcrete. The lime with a high pH level coats the hemp hurd or shiv and will prevent it from forming mould. Mould, fungi and rot need high moisture levels environments to thrive and will not live on the high pH levels of the Hempcrete.

## EXCELLENT SOUND ABSORPTION

Walls made of Hempcrete have a good acoustic absorption. Hempcrete is porous of structure, contains air and elements with high porosity (hemp hurd or shiv). It also has a thickness that guarantees to absorb sound waves. When rendered, a wall will reflect most of the sound  $\sim 900 \text{Vson m/s}$  (speed of sound per m/s) and will then absorb the remaining sound waves. Steel has a sound absorption of  $\sim 6100 \text{Vson m/s}$ . Hempcrete blocks which are denser have shown results of  $R_w 50 - 59 \text{ dB}$  at a density of 300-350.

The standard for internal walls in AU is  $R_w + C_{tr}$  should not be less than 50.

*What does  $R_w$  mean?*

The Weighted Sound Reduction Index ( $R_w$ ) is a number used to rate the effectiveness of a soundproofing system or material. Increasing the  $R_w$  by one translates to a reduction of approximately 1db in noise level. Therefore, the higher the  $R_w$  number, the better a sound insulator it will be.

*What does  $R_w + C_{tr}$  mean?*

$C_{tr}$  is an adjustment factor which is used to account for low frequency noise - typically the biggest problem with sound insulation.  $C_{tr}$  is always a negative number, so the  $R_w + C_{tr}$  will always be less than the  $R_w$  value. Many sound insulation types will represent how effective they are by displaying the  $R_w/R_w + C_{tr}$  values together.

## TERMITE RESISTANT

Tests performed with the fiercest termites in the country have proven that termites will not eat Hempcrete. The insect cannot withstand the Ph level of the mass and will not attempt to eat it. There is evidence to support that hemp/lime composite mixtures are considered as calcium carbonate (limestone) which is a termite resistant product.

AS 3.1.3. requires regular termite inspections regardless of the materials used in the construction. Visual barriers should be in place as per NCC 2022 Volume 2 Requirements.

## CARBON SEQUESTRATION

Like any plant, hemp uses the carbon dioxide ( $\text{CO}_2$ ) in air for its growth. One hectare of hemp can therefore absorb more than 15 tons of  $\text{CO}_2$  prior to reaching maturity. This  $\text{CO}_2$  is trapped in the Hempcrete and a life cycle analysis has shown that  $1 \text{ m}^2$  of a timber frame wall of 260 mm thick stores 75 kg of  $\text{CO}_2$ .

In accordance with French standard NF 10.010 (3), the 'greenhouse' impact of Hempcrete is  $-0.35 \text{ kg of CO}_2 \text{ eq./FU/year}$ , whereas the majority of materials used emit  $+0.50 \text{ kg of CO}_2 \text{ eq./FU/year}$



*An industrial hemp field*

## PHASE CHANGE PROCESS

Tradical® Hempcrete is effective due to the capacity of the Air lime + Hemp composite to manage water through a 'phase change process' leading to three properties

- When the ambient outdoor temperature falls, moisture on the inside of the wall condenses into droplets, releasing energy and thus compensating for the drop in temperature. This interaction keeps the ambient indoor temperature relatively warm creating a feeling of comfort.
- Inversely, when the ambient outdoor temperature rises, moisture on the inside of the wall evaporates, consuming energy and thus maintaining the temperature on the surface of the wall.
- In both cases, variations in temperature are countered thanks to this natural regulative process.

Tradical® Hempcrete is not simply insulation—it offers outstanding hygrothermal dynamics.

Tradical® Hempcrete is proactive and **CONSTANTLY** compensates for variations in temperature and relative humidity to guarantee **STABLE** and comfortable indoor conditions.

## 7. The Ingredients

---

### 7.a. HEMP

Plants have always been used in construction, but modern technologies have omitted them to a large extent. The development of production methods, the need for materials that are compatible with sustainable building practices, consumer expectations, and regulatory requirements have led to a growing interest in their qualities.

Among the plants that can be used for construction, hemp certainly holds a prominent place and can be considered a prime example. As an environmental and ecological plant Hemp has been an essential crop for centuries and thus forms part of our history. Hemp, also called industrial hemp, is a Cannabis sativa variety that does not contain THC. Today, its technical qualities, its suitability as an industrial plant, and its environmental friendliness enable it to adequately meet requirements that often are contradictory. Hemp is a particularly robust plant that is able to quickly produce great quantities of matter with minimal use of fertilisers, without needing any irrigation or phytosanitary treatment (herbicide, fungicide, or insecticide), while improving soil structure.

The "woody part" of the stem hemp hurd or shiv is made up of small parallel channels that carry the sap and are filled with air once the stem is dry. Hurd particles have a very low density and are very efficient from a thermal and acoustic perspective. They are used as an insulating aggregate for the preparation of lightweight insulating mortars and 'cretes' (Hempcrete) that benefit from their porous structure.

After decortication, 25% of the plant is fibre, 5% dust, 70% hemp hurd or shiv that can be used for building.

One hectare (2.5 acres) of hemp is sufficient to build an average size house. One hectare of hemp captures more than 15 metric tonnes of CO<sup>2</sup> during its growth.

The Hemp plant absorbs atmospheric CO<sup>2</sup> during the plant growth phase, and again as the material gains strength and matures: 100m<sup>2</sup> with 300mm thick walls will lock up 7.9 tons of CO<sup>2</sup> in the walls. Estimated rate of carbon sequestration is 165Kg CO<sup>2</sup> capture/m<sup>2</sup>. Therefore, building with Hempcrete reduces atmospheric CO<sup>2</sup>.

- Apparent mass density: Approx. 110 kg/m<sup>3</sup>
- Thermal conductivity  $\lambda$ : 0.048 W/m.K
- Packaging: Chanvribat 20 kg bag, i.e. approx. 200 litres (broken up)  
Hempflax® 10 kg bag, i.e. approx. 100 litres (broken up)
- Storage: Unexposed to the elements and dry

#### Characteristics of BUILDING GRADE hemp hurd or shiv:

Generally, the particle sizes of BUILDING GRADE hemp vary from 1 to 5mm wide, and from 1 to 30mm long.

Hemp that meets the criteria can be used in hemp construction and will be subject to the Tradical® Hempcrete Warranty.

Hemp hurd or shiv that has been affected by moisture will continue to rot. Signs of deterioration are: mould, humidity, dark (grey) coloured patches on the particles and a musty, mouldy smell. This hemp cannot be used for building purposes and is recommended to use as garden mulch instead.

An excess of dust or fibre particles found in the hemp should be reported to OzHemp before use.

Excess of fibre will influence the proper mixing, drying, hygroscopic function and insulation of the product. It can lead to rotting of the Hempcrete wall.

### **7.b. TRADICAL® LIME BINDER**

Aerial lime is produced by firing the purest limestone to 900°C.

In all civilisations and on all continents, mankind has been able to draw upon this sound and natural material to build such varied structures as foundations, bridges, water supplies, waterproofing, tanking, masonry, renders, and whitewashes.

The aerial lime produced in the factories of the Lhoist Group today can be used to manufacture high-technology products, thanks to end-to-end control of the production chain.

Whether pure or in formulations, BCB Aerial Limes feature the Tradical® label, representing the stringent quality requirements of its products, based on characteristics including the regularity of their fineness, their very high level of free lime, and their stability.

In the Hempcrete mix aerial lime is less dependent on water for its setting than hydraulic binders and provides high capillarity. However, it is difficult to use aerial lime in its pure state and, thanks to BCB's expertise in aerial lime technology, it has developed TRADICAL® binders that are specifically designed for the problems that Hempcrete can pose.



*A lime quarry*

The TRADICAL® Hempcrete range is based on extremely pure Aerial lime (as per standard BS EN 459 : 2010 ) as well as Hydraulic and Pozzolanic binder (as per standard ASTM C-1707)

	Tradical® <b>PF 70</b>	Tradical® <b>THERMO</b>
<b>Product description</b>	<ul style="list-style-type: none"> <li>Class FL A 3.5 air lime according to standard NF EN 459.</li> <li>Lime for standard Tradical® Hempcrete applications</li> </ul>	<ul style="list-style-type: none"> <li>Class FL A 3.5 air lime according to standard NF EN 459.</li> <li>Lime for standard Tradical® Hempcrete applications</li> </ul>
<b>Technical data</b>		
<b>Ingredients</b>	Air lime with 98% Ca(OH) <sub>2</sub> 80%  Hydraulic binder                      20%	Air lime with 98% Ca(OH) <sub>2</sub> 75%  Hydraulic binder                      25%
<b>Apparent mass density</b>	0.65	0.56
<b>Packaging</b>	<b>22</b> kg paper bag on 50-bag pallet	<b>18</b> kg paper bag on 60-bag pallet
<b>Weight of one pallet</b>	1100 kg	1080 kg
<b>Pallet dimensions</b>	H x L x W = 150 x 90 x 110	H x L x W = 150 x 90 x 110
<b>Storage</b>	Unexposed and dry	Unexposed and dry

The TRADICAL® Render Range is based on Mineral fillers, unfired limestone (CaCO<sub>3</sub>) with a well-graded particle size distribution enabling aggregate coating and bonding.

	Tradical® <b>PF 80</b>	Tradical® <b>Bâtir</b>	Tradical® <b>Décor</b>
<b>Product description</b>	<ul style="list-style-type: none"> <li>Formulated air lime with a mineral content enabling aggregate coating and bonding.</li> <li>This white lime is used with Chanvribat® to prepare a hygrothermal render with a creamy finishing texture.</li> </ul>	<ul style="list-style-type: none"> <li>Class FL A 3.5 air lime according to standard NF EN 459.</li> <li>This white lime is used with Chanvribat® to prepare a hygrothermal render with a standard finishing texture.</li> </ul>	<ul style="list-style-type: none"> <li>Under the conditions prescribed by standard NF EN 459.</li> <li>Thin aerial lime render for interior smoothing and finishing, 80 colours</li> </ul>
<b>Technical data</b>			
<b>Ingredients</b>	Mineral fillers                      35% unfired limestone (CaCO <sub>3</sub> ) with well-graded particle size distribution  TRADICAL® PF 80 binder      65% -Air lime with à 98% of Ca(OH) <sub>2</sub> 84% -Hydraulic binder                      16%	Air lime with 98% Ca(OH) <sub>2</sub> 80%  Hydraulic binder                      20%	Air lime                                      80%  Hydraulic binder                      20%
<b>Apparent mass density</b>	0.85	0.61	Density < 1.16 +/- 0.05 kg/dm <sup>3</sup> Particle size distribution: 1 mm
<b>Packaging</b>	<b>20</b> kg paper bag on 40-bag pallet	<b>20</b> kg paper bag on 40-bag pallet	<b>25</b> kg paper bag on 40-bag per pallet
<b>Weight of one pallet</b>	800 kg	800 kg	1000 kg
<b>Pallet dimensions</b>	H x L x W = 150 x 90 x 110	H x L x W = 110 x 120 x 110	H x L x W = 110 x 120 x 120
<b>Storage</b>	Unexposed and dry	Unexposed and dry	Unexposed and dry

The Hempcrete described in this guide has been developed in collaboration with professionals to meet their expectations and has been used on a wide range of construction sites for the past decades with unrivalled functional reliability.

### 7.c. WATER

Water in the Hempcrete mix will do the following:

1. Start the process of absorbing water by the hemp hurd or shiv particles;
2. Start the chemical process where ingredients of the binder are activated;
3. Transform the binder powder into a slurry;
4. Create a composite with a consistency that is neither runny nor firm.

Water used in the mix has to be clean and free of contaminants.

## 8. Protection / Safety / Hazards / First Aid

---

Work health and safety in the construction industry is regulated by states and territories.

According to the WHS Regulations, everyone working or visiting a building site must be aware of the possible dangers and have completed a safety training course. As a builder, you carry certain responsibilities. Make sure you know about them and follow the protocols. Working with Hempcrete is generally safe and light work compared to bricks, concrete and concrete blocks, but involves certain dangers.

A work method statement must be prepared for each high-risk activity undertaken on a construction workplace.

This work method statement will describe how certain work activities are to be undertaken so that workplace health and safety will be ensured.

Specifically, the statement documents the risk management process in relation to certain hazards associated with undertaking these work activities.

A work method statement must be prepared for each high-risk construction activity that will be undertaken on the site.

Generally, the person responsible for undertaking the high-risk activity needs to prepare and present the work method statement.

The Principal Contractor must not allow the relevant person to start work on a high-risk activity until the work method statement is presented and is accepted. Additionally, work must not commence or continue unless it is undertaken in a way which complies with the work method statement.

The White/Blue Card is a mandatory requirement that provides new and existing workers with the basic understanding and knowledge of safety needed to start or continue work within the building and construction industry.



### 8.a. WORKING ON LADDERS AND SCAFFOLDING

Risks must be managed as per AS/NZS1657 if a person could fall less than 3 metres (housing construction), 2 metres (other construction) or if work is performed on a roof pitch under 26° e.g. a pitch of 1-25°.

At the time of print the following legislation is being reviewed. State-based legislation and the national code of practice for fall prevention applied once a person was



working at a height of 2 metres or more. This limit is about to be replaced with an obligation to minimise the likelihood of a fall from any height.

(source: <http://www.workplaceaccess.com.au/knowledge-centre/code-of-practice/>)

When working with lime products, all standard safety regulations must be in place.

TRADICAL®PF 70 contains: non-hydraulic lime, hydraulic lime and cement. These lime products are considered Hazardous Substances.

Clear instructions must be given to anyone handling the products summarising the safety aspects involved with working with these hazardous powders.

Contact with the eyes and skin from both wet and dry products must be avoided as there is a risk of serious damage to eyes.

Lime can irritate the skin if in contact with moisture and could cause burns.



## WEAR YOUR PPE!

The following information is taken from:  
**Designated Hazardous Substances  
NOHSC:10005(1999)**



**THIS PROTECTIVE EQUIPMENT  
MUST BE WORN  
ON THIS SITE**

### 8.b. EYE PROTECTION

**S24/25:** Avoid contact with skin and eyes.

**R36/37/38:** Irritation to eyes, respiratory system and skin.

Have an eye wash emergency kit on site!  
KNOW WHERE IT IS AND HAVE IT WITHIN REACH!

Have plenty of household vinegar available to wash skin. It neutralises the lime activity that may cause burns on your skin.

Wear eye protection (AS/NZS 1337) to avoid liquid lime splashing into eyes from the mixer.



### 8.c. SKIN PROTECTION

**S36/37/39:** Wear suitable protective clothing, gloves and eye/face protection.

Wear long sleeves and pants, rubber gloves with fabric cufflinks (AS 2161)

Gloves need to be of a good quality, waterproof, without holes and long enough to cover most of the under arm. Lime in combination with water burns and with friction of clothes will cut into the skin and leave open wounds that are hard to heal when continuing to work with the products.

Household vinegar should be kept on site at all times. Vinegar neutralises the lime and prevents it from continuing burn into opened skin. Rinse affected area with water, dry and generously apply the vinegar.

**S20/21:** When using do not eat, drink or smoke. Wash your hands before eating.





## 8.d. RESPIRATORY PROTECTION

**S22:** Do not breathe dust.

**R20/21/22:** Harmful if inhaled or in contact with skin or if swallowed.  
Avoid breathing dust.

**R48/20:** Danger of serious damage to health by prolonged exposure through inhalation.

**S38:** In case of insufficient ventilation, wear suitable respiratory equipment.

When exposed to dust also wear a respirator (AS/ANZS 1715, 1716).

It is suggested you purchase a dust mask with filters.



## 8.e. ENVIRONMENTAL PROTECTION

**S29:** Do not empty contaminated water into sewerage or drains.

**S61:** Avoid release to the environment. Refer to special instructions/safety data sheets.

Stick to the housekeeping standards for building sites. Keep all packaging together and dispose according to the environmental regulations. Hempcrete can be re-used. See Mixing (next page).

## 8.f. FIRST AID

**Eyes:** Use the eye protection kit, follow instructions. Irrigate eyes as soon as possible with lots of water.

**Lungs:** Leave the dusty area if inhalation occurs. Seek medical advice if needed.

**Skin:** Wash skin with vinegar and water and use a moisturiser.

**Ingestion:** Rinse mouth with water. Do not induce vomiting.

Seek medical advice if required.



## 9. Physical characteristics of the material

Hempcrete falls into the category of 'light building materials' with specific features:

- Flexibility
- Good thermal insulation
- Good acoustic absorption
- High permeability to humidity
- Good fire resistance

Hempcrete is used to construct monolithic walls. Air-tightness and air leakage through the walls is negligible. Tests came to approx. 0.75 g/m<sup>2</sup>/mmHg. Typical air leakage 1-3 air changes/hour @ 50 pascals. This is only observed in unrendered walls, rendered walls can achieve significantly better airtightness.

Testing for strength and flexibility is done according to AS1012.9 and AS 1478 2 Appendix D (concrete testing) by putting pressure on test cubicles until they fail. The compression is determined by test samples cured over minimum of 28 days.

## 10. Mixing

---

Hempcrete is a mix of Industrial Hemp hurd or shiv, water and a lime binder. There are four types of Hempcrete mixes;

- Wall mix low density
- Wall mix high density
- Floor and ceiling mix
- Hemp render mix

Each mix has its wet and dry weight, strength properties and specific installation methods. See the application chapters.

### 10.a. MIXING Hempcrete

Mixing of Hempcrete is the core of success and is an essential part of the Hempcrete building process. Mix that is too wet will take too long to dry and risks causing the wall to fail; mix that is too dry will not bond and will crumble and de-laminate from the frame structure etc. Stick to the guidelines of this manual and manufacturer's recommendations. When in doubt contact the supplier.

The best proven method for mixing Hempcrete is in a pan mixer or rotary screw mixer. Pan mixers are available in several sizes for example 120 litre, 360 litre and 750 litre. They are driven by mains power in 2 and 3 Phase or with petrol engines, hydraulics or by a universal joint. Slower speeds of the mixing arms will work more safely and better.

Standard drum mixers can be used but great care needs to be taken as there is a risk of formation of balls of Hempcrete that remain dry inside or a risk of creating a mix that is too wet.

Good mixing practice is to be well organised, i.e. the supply of materials. For example, have everything near the mixer beforehand and work with measured water quantities. The supply of the Hempcrete mix needs to be constant and within the period that the installers are able to transport and process it. A fresh mix should not sit for a long time uncovered. Have plastic covers or damp cloths on hand to cover the fresh mix to protect it from sun and wind and place in shade to avoid setting before application.

### 10.b. REUSING Hempcrete

Once the mix has set prior to application, reuse part of it in a new batch. If application of a batch is not optional, spread it out on a tarp and break it into small crumbs as soon as possible. It requires considerable amounts of energy to break down lumps of Hempcrete to reuse in a mix. A maximum of 10% recycled Hempcrete is recommended to be used in a new batch. Reused Hempcrete is a good base for floor and ceiling insulation.

The hemp hurd or shiv is subject to any change in humidity related to the storage and weather conditions. This will influence the mix significantly.

The mix should be examined constantly to ensure its consistency and the particles of hemp are well covered by the binder.

Monitor safety precautions at all times.

Avoid the breathing of lime dust.

Wear protective clothing, gloves (AS 2161) and eye protection (AS/NZS 1337)

Wear respirator protection (AS/ANZS 1715,1716)

## 11. Mixing Method

---

### 11.a. THE PAN MIXER

The ratio of lime and hemp should be adapted to the volume the pan mixer can handle without spilling, whilst being able to mix the materials thoroughly. For efficiency and to avoid double handling the mix proportions should ideally break down to increments of half bags of hemp shiv and lime binder, i.e. 1 or 1.5 bags; 2 or 2.5 bags and so on depending on mixer capacity.

Have the water quantity required for the mix measured off. This can be done in an overhead container by simply scooping buckets out of a supply drum or using a hose fitted with a digital volume readout.



*Imer 120 litre pan mixer*



*Imer 360 litre pan mixer*

### 11.b. STANDARD BARROW MIXER

Mixing Hempcrete with a standard drum mixer is not recommended for larger projects. Please contact OzHemp if you have a project where a drum mixer is utilised.

### 11.c. RECOMMENDED WORKING CONDITIONS

Mixing the Hempcrete above 30°C or under 5°C is not recommended. The moisture of the fresh batch will be hard to monitor; the moisture of the previously installed layer will be hard to manage in order to adhere properly to the new layer.

Heavy rain will affect the lime content of the exposed freshly laid Hempcrete layer. The new work will need to be sheltered from rain. Rainfall will wash the lime content away and create areas in the wall of just hemp without binder. These areas will have to be scratched out and replaced for the correct mix. Dry winds will affect adhesion between previous and fresh layers. Monitor moisture content at all times of new and old work by capping the top of the walls with builder's plastic. A hose with a nozzle that has a mist function should be available where new Hempcrete walls are constructed.

## 11.d. STEPS OF MIXING:

1. Put the hemp in the mixer. Break up any hemp lumps.
2. Turn mixer on. - Ensure the blades are not within reach of hands and are secured with grills.
3. While the hemp is rotated by the mixer blades, spray the hemp with water mist. This will create a change of colour and dampen the hemp and activate the capillary action of the dry particles so the lime will adhere to the particles.
4. If needed, add up to 10% re-used broken up Hempcrete.
5. Add the TRADICAL®PF70/Thermo binder required for the mix.
6. Spread the measured quantity of water over the mix.
7. Let the mix form to a homogeneous consistency over a period of approximately 3 minutes.
8. Add water with spray nozzle until the right consistency is achieved. A mix that is too wet is unusable. Be moderate with adding water at this stage and take your time to get it right. The mix should look and feel like a 'dryish porridge'.
9. Unload the mixer as soon as possible.

## 12. Get Set Up for the Job

---

What you need:

- Mixer
- Buckets or baskets for transportation of the Hempcrete
- Trolleys to transport the buckets
- Water hoses with nozzle
- Shovel, snow or bark shovels are good for moving hemp hurd or shiv
- Broom: when the workflow is kept clean you can recycle spoiled Hempcrete
- Rake, to rake out the Hempcrete in between the rafters and joists
- Hand rake, to scratch previous Hempcrete layers that have gone hard to encourage adhesion or 'key'
- Concreting tools such as a screed, trowels
- Tamping tools, long handle, short handle
- Formwork, see Formwork (Section 13)
- Spacers, see Formwork (Section 13)
- Fasteners such as hex head timber screws
- Hand tools, impact driver
- Clamps
- Brushes and brooms, see Formwork (Section 13)
- PPE, Personal Protection Equipment
- Standard Carpenters' tools such as levels, impact drivers, hammer etc.
- Scaffolding, planks or mobile scaffolds. Ensure all safety measures are in place regarding working on height as per AS/NZS1657
- Tarps, builder's plastic, tape and ropes
- Pallet jack, trolley



## 12.a. THINGS TO CONSIDER AND PLAN

Hemp hurd or shiv and Binder will come on pallets on a side loader or out of a container. Unloading is done by hand, but preferably with a forklift and or pallet jack. Having the materials under cover, out of the weather and close to the mixing station is essential. The materials for the whole job can be offloaded (with a hired forklift or by hand) and stored in the building where the Hempcrete is required or in a hired container.

Materials can also be carried to site on a daily basis when stored elsewhere.

With a good crew and equipment, one can mix and place up to 8-10 m<sup>3</sup> per day.

Equipment needs to be washed after using it. It is recommended to allocate a designated area where the formwork and equipment can be washed. Take into consideration that the drainage of the washing water will have to comply with the local guidelines of erosion settlement control on building sites.

While water conservation is a given, it is feasible to wet and soak formwork straight after it has been released from the Hempcrete and this is a good site management practice. Hand brooms can be used to clean formwork, machinery and tools. Lime and therefore Hempcrete will stain flooring and splashes can leave permanent marks on paintwork, window frames and other finished building elements (walls, garage doors, posts, soffits etc.). Save yourself a tedious clean up and re-coating session. Cover these surfaces where needed.



*Snow or bark shovel*



*Shipping containers make for great secure storage*

## 13. Formwork

### 13.a. PERMANENT FORMWORK

The principle is that as this 'membrane' will remain a coating of the Hempcrete, it will therefore have to be vapour permeable at all times. Non-vapour permeable materials would be: steel, aluminum, plastic, glass, cement sheet.

Examples of Permanent Formwork Materials:

#### (i) Magnesium board

Thickness up to 12 mm magnesium board attached to timber frame. Attached with gal/stainless flat staples or flat head screws, optional to add adhesive. See manufacturer's installation guide.

#### (ii) Bamboo / Reed mats

The mats come in dense and less dense varieties. Can also be used for Hempcrete insulated ceilings. attached to studs with gal/stainless flat staples.

#### (iii) Perforated building paper and glass fibre mesh.

These fabrics will have to be perforated and attached tightly to studs with gal/ stainless flat staples or timber laths fastened to studs. The membranes will deform with the weight of the Hempcrete. This can be avoided with temporary strutting i.e. by having an element to brace or strengthen a framework by resisting stress or compression.

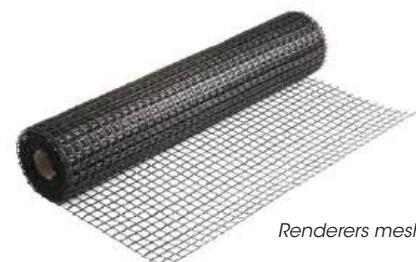

*Renderers mesh*

### 13.b. TEMPORARY FORMWORK

The principle is to:

- hold the fresh Hempcrete in place
- withhold the pressure of the tamping without deforming
- be able to manoeuvre and to install and un-do
- be not too heavy
- be easy to clean, preferable non-stick
- be re-usable
- able to make plumb and level.

Steel sheeting, plastic formwork, such as Geoplast®, multiplex, timber planks and form ply sheeting can be utilised to create the temporary formwork modules.

The panels should be between 500 and 800mm high for ease of filling the cavity from the top. They should be able to reach to the bottom.

Placing of the formwork should be accurate, sound, level and plumb. Take into consideration that panels (especially black coloured) that absorb a lot of heat from the sun will adhere better to the skin of the Hempcrete and will therefore be harder to clean. Keep in shade or moist where possible.

Checking of the frame is recommended prior to commencing the formwork installation. Plan ahead and set the thickness plumb line with screws that project from the framework.

Spacers such as bugle or batten screws can be used to ensure consistent spacing between the formwork and the frame, also fixing the thickness of the wall. Allow the screws to be removed from the wall as they could create RUST stains through the render.

The framework must be structurally sound and secured in accordance with AS3610.1:2018 requirements. Formwork with a minimum thickness of 12-15mm should be used.

Lightweight Geoplast® formwork is fast to erect, inter-lockable and made of reinforced recycled plastic. The formwork components come in a variety of sizes and corner configurations.

Hempcrete is much lighter (approximately one sixth) than concrete. Releasing agents are not to be used on the formwork as they tend to interfere with the adhesion of the Hempcrete and the render coats further down the track.

Removal of formwork is done by sliding the panels sideways. As soon as the Hempcrete sets, the formwork can be removed. Depending on weather conditions this can be done between 30 minutes and one hour later. The longer the panels stay on, the longer the drying process will take.

The recently used panels should be immediately cleaned with water and brush.

Working on scaffolds should be done in accordance with OHS standards. Advice is in the section on Safety.

Protect the top of the fresh wall from absorbing rainwater and drying out too fast if another layer is to be adhered to it.



## 14. Framed walls

Hempcrete is a non-load bearing wall infill. Buildings that have walls of Hempcrete need to have the roof and floor loads supported by timber post and beams, concrete or steel supports, or by timber stud frames.

The structural components have to be designed by a qualified engineer and comply to AS 1684.2.

Hempcrete walls are considered an insulating exterior wall cladding as per NCC 2022, Volume 2, H2D6 and H6D1 the external face must have a protective covering e.g. render or cladding.

### 14.a. STUD FRAME

All timber frame construction is required to meet Australian Standard AS1684-2010 parts two, three and four. This manual covers timber framed work of maximum stud spacings of 600mm c/c. Consult your engineer's drawings and notations.

Smooth timber has less adhesion to Hempcrete than rough surface timber, where adhesion is crucial; for instance where the framing is bulky, roughing up the timber would help adhesion.

This can be achieved by creating little cuts using a saw or angle grinder. Ties or keys can be made of dove tail split studs, thin slats, plastic mesh or concrete chains attached to the frame.

The position of the frame can be in the middle of the Hempcrete wall or exposed to the interior of the wall. When exposed to the inside of the building the frame can be clad with permanent formwork. This saves forming up the wall on the inside and will ease mounting of electrical and plumbing fittings and fitting windows. As the Hempcrete needs more grip throughout its depth, additional framing that reaches towards the middle of the wall is recommended. Diagonally split 90 x 45 or 90 x 35 studs are available at most building material supplies companies.

The framing noggins can be tilted away from the side of the application. This will make the Hempcrete application easier.

Engineered timbers have minimal shrinkage against green hardwood. The average humidity of the studs should not exceed 20%.

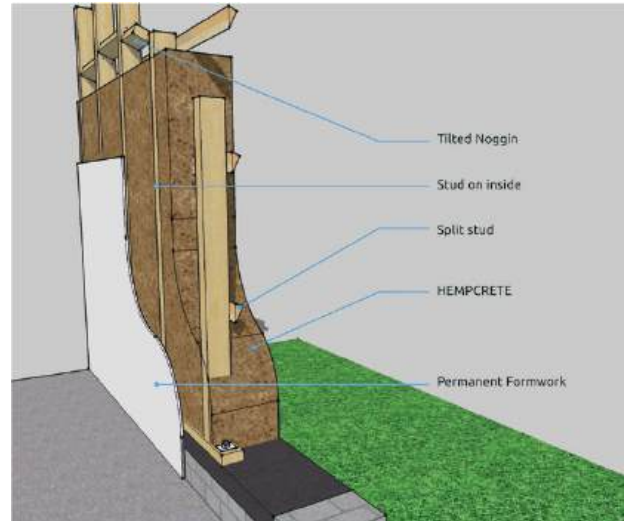

Hempcrete wall on concrete slab, frame on inside of wall



Tilted noggin



Skirting Sleeper

### 14.b. EMBEDDING FRAME ELEMENTS WITH Hempcrete

The thickness of Hempcrete from the frame to finished wall surface should be 70-90mm minimum - see table below:

#### HEMPCRETE COVER OF FRAMING ELEMENTS

X* - WIDTH OF FRAMING ELEMENT	Y* - MINIMUM THICKNESS OF Hempcrete COVERING THE ELEMENT
40 mm	70 mm
50 mm	75 mm
60 mm	80 mm
70 mm	85 mm
80 mm	90 mm

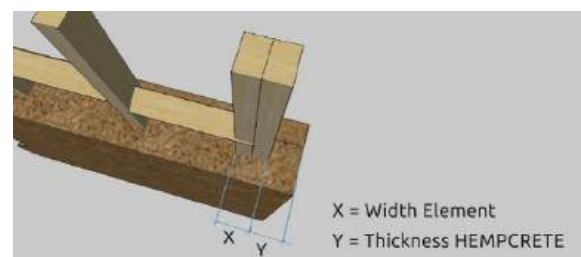

\*refers to image at right of this table

When studs or lintels are covered with Hempcrete, the layer covering it needs to augment its thickness.

Studs to support wide openings are often combined and nailed together. This can lead to about 5 studs of 35mm wide or 4 studs of 45mm wide, giving a stud width of around 180mm. As those studs are often the end of a wall, it is essential that the Hempcrete adheres properly to it.

This can be achieved by:

1. good moisture control of the stud when applying the Hempcrete;
2. installing key elements such as plastic mesh, angled timber and stainless screws or nails;
3. after application and initial drying of the Hempcrete, fitting embedded (5mm) plastic washers with screws coated with waterproofing paint.



*Plastic washer and long gal screw - on a narrow Hempcrete column*

### 14.c. BRACING AND TIE DOWN

Hempcrete walls that have dried for more than 90 days provide a very good even distribution of bracing. Hempcrete walls can be braced with diagonal timber (notched or not notched) or gal steel strapping that is coated with a waterproofing or bituminous paint. A Hempcrete wall with bracing ply in the middle is not recommended. If there is no way around the issue, sufficient adhesion of the Hempcrete on both sides of the bracing will have to be provided. The frame is likely to move and delaminate the Hempcrete attached to it. Drying could also take more time, affected by the bracing ply, although bracing ply would be considered breathable to a certain extent.

Bracing should be discussed with the engineer. Under no circumstances should bracing be altered or removed without the engineer's approval, and it must always comply with AS 1684.2:2010 requirements.

All buildings must be engineered to meet the specific regional tie-down codes in accordance with NCC 2022, Volume 2, H1D5 requirements.

All steel and galvanized elements, such as tie-down connectors, hangers, boots, nail plates, triple grips, and rods, must be sleeved or bitumen-coated to prevent corrosion. Garden irrigation pipe is a cost-effective option that fits easily over 12mm rods.

All corrosion protection shall be in accordance with AS/NZS 1214:2016, AS1397:2021, AS/NZS 4791 and AS/NZA 4534 requirements. Presence of salt or proximity to the sea, exposure to weather, the type of timber treatment, moisture content have to be considered as per NCC 2022 requirements.



*Hebel or Besser Block raiser*

Covering big steel beams requires great care Adhesion of the Hempcrete will have to be created by timber or plastic elements and corrosion prevention of the welds needs to be applied thoroughly. To fit big beams with sheet cladding that can be insulated and rendered will reduce risks of cracking and delimitation and will most likely save in labour costs.

### 14.d. FRAME ON SLAB

Depending on the building regulations of the state, the lowest part of an exterior Hempcrete wall, when constructed on a slab, should have a minimum of 150mm ground clearance. If this is not a mandatory requirement of the state, the slab must be fitted with a ledge of 150mm of the FGL (Finished Ground Level). This can be achieved with a concrete wall cast onto the slab, core filled Besser block wall or brick or stone wall.

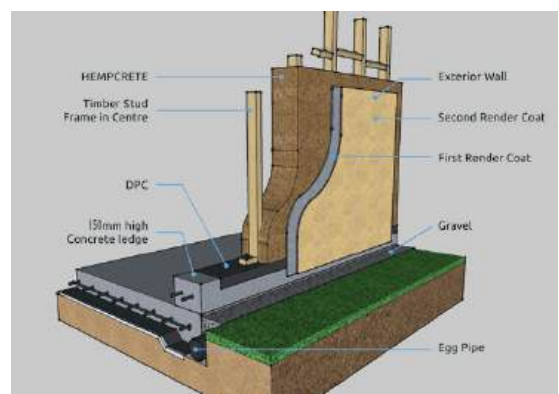

*Hempcrete wall on concrete slab, frame in middle of wall*



Keep in mind that:

- A) this wall will create a thermal bridge and should be insulated - for example with slab edge insulation - to form the same thickness as the Hempcrete wall on top of it,
- B) this wall will have to provide adequate tie-down to the slab as per engineer's specifications.

**Caution** A capillary break must be installed between the foundation and the Hempcrete to prevent humidity from the slab or concrete ledge from contacting the lower part of the Hempcrete wall. This can be achieved by installing a damp-proof course (DPC) with a minimum of D80 shore hardness, or by using aluminum and bitumen flashing in accordance with NCC 2022 requirements. Alternatively, a DPC that also functions as a termite barrier can be used to protect the timber framing. It is recommended to have gravel-filled trenches around exterior walls to drain excess water away from the footings and slab.

### 14.e. FRAME ON SUSPENDED (TIMBER) FLOOR

When installing Hempcrete walls on a suspended timber floor, one needs to pay attention to the joint between the bottom of the Hempcrete wall and the FFL (Finished Floor Level).

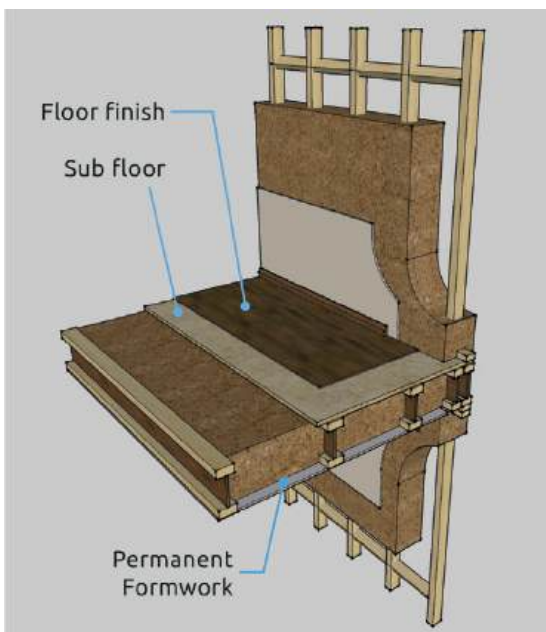

*Hempcrete wall and floor junction*

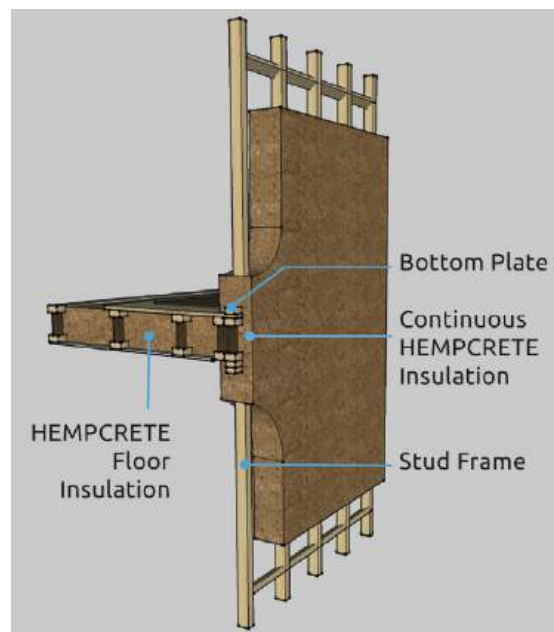

*Hempcrete wall and floor junction*

The best finish resulting in the best insulation, is to continue the wall until under the bottom plate, filling the cavity between the joists. Be sure to install additional key material and preferably a permanent formwork on the bottom of the wall. Exterior render should be applied with a drip line.

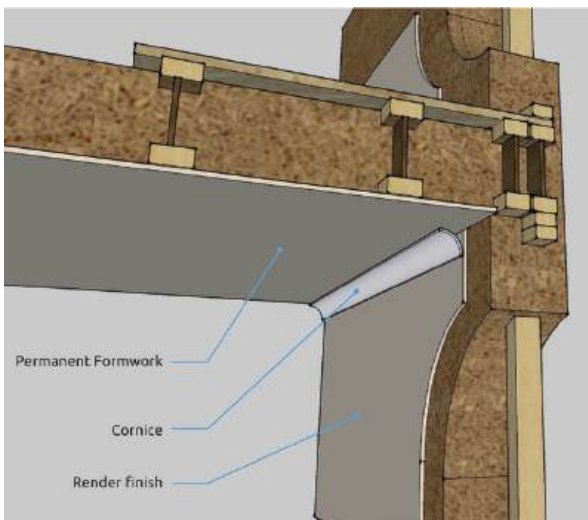

*Hempcrete wall and floor junction detail 1*

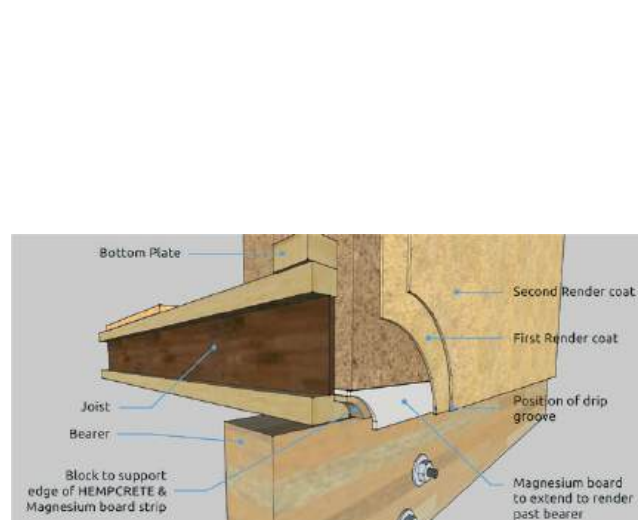

*Hempcrete wall and floor junction detail 1*

## 14.f. BATHROOMS AND RETAINING WALLS

### OPTION 1:

Should you choose to install ceramic tiles over Hempcrete, the bathroom walls should be fitted with a false wall of cement sheet and waterproofed to AS 3740-2010 2.2.1 and 2.2.3 of the AS Bathroom Waterproofing Standards. There should be a ventilated gap between the inner bathroom wall and the Hempcrete wall.

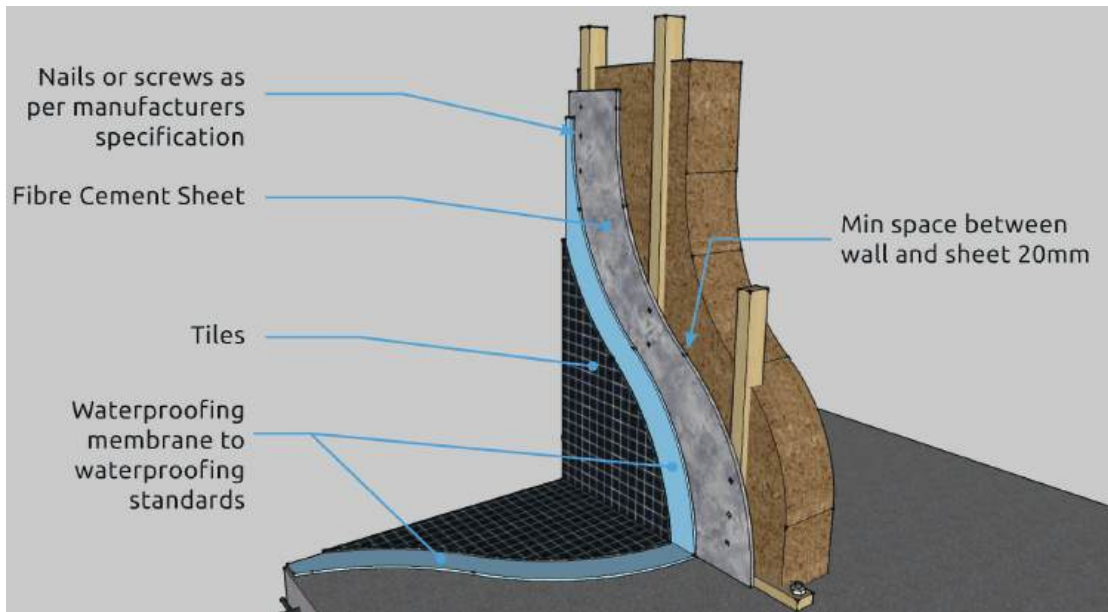

Option 1

### OPTION 2:

When it is not possible to install the ventilated gap between the cement sheet and the Hempcrete wall, cement sheet such as Villaboard can be installed with the recommended adhesive directly to the Hempcrete wall. Waterproofing to AS 3740-2010 2.2.1 and 2.2.3 of the AS Bathroom Waterproofing Standards and tiling can follow as per standard procedure.

**Caution** It is essential that Hempcrete walls fitted with cement sheets can breathe. The side of the wall that is not sheeted should be finished with just a render and have no obstructions fitted.

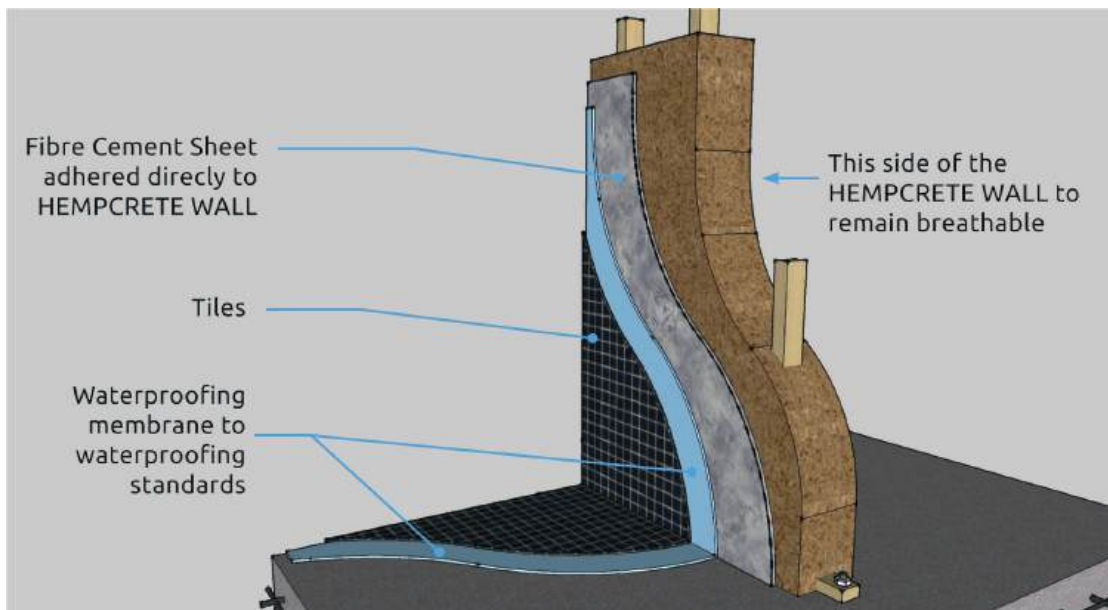

Option 2

### OPTION 3:

You may use Hempcrete in a bathroom and finish with Tradical® PF80 render. Tradical® PF80 render has water repellent properties and is ideal for wet areas and exterior walls.

Alternatively, you could finish with lime render coated with an approved water repellent agent that will breathe and regulate moisture. Care must be observed that only approved vapour permeable water repellent coatings meeting the required performance are used. The remaining bathroom should be waterproofed to AS 3740-2010 2.2.1 and 2.2.3 of the AS Bathroom Waterproofing Standards.

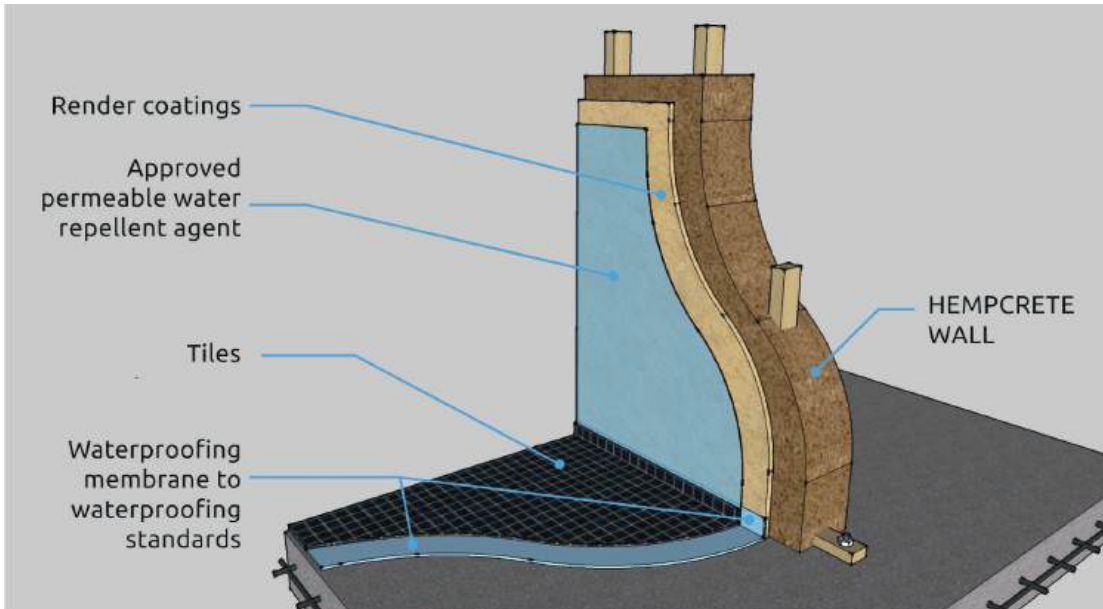

Option 3

### RETAINING WALLS

Hempcrete is a material that will absorb and expel humidity. Hempcrete is not suitable as a retaining wall due to the high constant humidity of the soil behind it.

### 14.g. ELECTRICAL

All electrical, internet and phone wiring must be ducted. The ducts must be separated by 20-30mm distance in order for an even distribution of Hempcrete in the wall. Between the ducts embedded into the wall and the surface, there must be a layer of at least 20mm of Hempcrete.

Conduit and sockets should be installed as per NCC 2022, Volume 2, H1D6 requirements. Steel clips need to be coated as per item 14k of the OzHemp Tradical® Installation guide.

Before loading the electrical circuit, allow approximately a month for the Hempcrete walls to dry.

To retrofit wiring in a Hempcrete wall a minimum groove of 40 mm deep can be made to fit the new conduit. A dense batch of Hempcrete will refill the remaining space of the groove to be finished with render after drying.

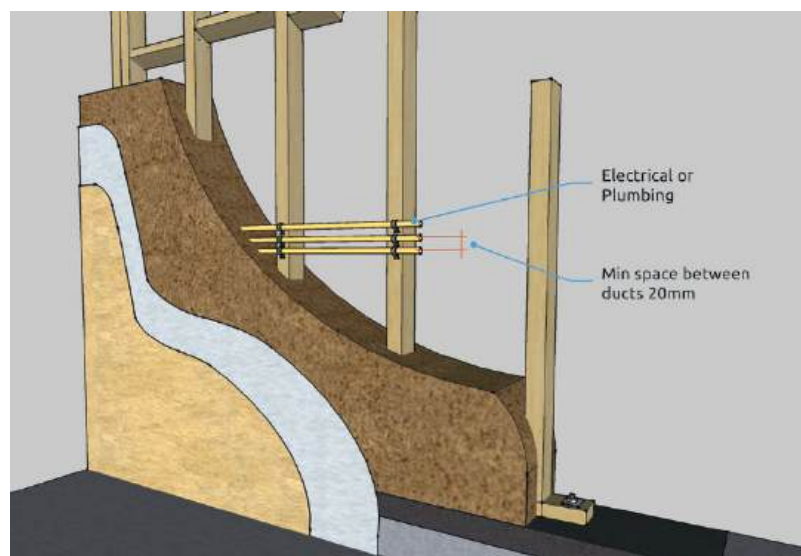

Embedding services into a Hempcrete wall

#### 14.h. PLUMBING

All embedded pipes made of copper, metal and zinc including couplings with metal components must be lagged, sleeved and/or coated and clipped as per AS/NZS 3500 2.8.3 and installed to AS 3.4.2.6. Steel clips need to be coated. Expanding foam can be used to fill holes created by larger service openings. Allow at least 50mm of Hempcrete between the wall surface and all pipes.

**Caution** Pressure test the water system prior to installing Hempcrete and again prior to applying the render coats.

#### 14.i. TERMITE PROOF

Stud timber is mostly T2 or termite proofed. Even though Hempcrete is termite proof it is recommended to keep the timber used for framing termite proof.

In accordance with standard building practices, termite proofing and barriers must be installed. Standard termite inspections should be conducted as outlined in AS3660.1:2014 Termite Management 1 and in compliance with NCC 2022 Requirements.

In new building work, a visual barrier of at least 75mm should be in place as per NCC 2022 Volume 2 H2D2.

Comprehensive testing has shown Hempcrete is naturally termite and pest resistant.

#### 14.j. TIMBER POST AND BEAM CONSTRUCTION

Constructions designed with post and beam supports have the loads divided over fewer members and are therefore bigger in size.

When the openings of a post and beam construction are filled in with Hempcrete walling, a timber frame will have to be fitted to provide a 'skeleton' to the wall. Timber studs of this wall can be a minimum thickness of 35 x 35mm with a maximum spacing of 600mm c/c. This frame will also function for fixing services.

Door and window openings need to be secured appropriately to floor and ceilings.

#### 14.k. STEEL FRAMES

When Hempcrete is used in conjunction with a steel frame, the steel frame must be treated against corrosion in accordance with AS/NZS 1214:2016, AS 1397:2021, AS/NZS 4791 and AS/NZS 4534 in compliance with the NCC 2022 requirements. The optimum protection treatment should combine appropriate surface preparation of the frame and suitable coating materials. All fasteners used must be either stainless steel or zinc galvanised and coated.

#### 14.l. CONCRETE POST AND BEAM CONSTRUCTION

Structures supported by concrete posts and beams can be fitted with Hempcrete as described in timber post and beam construction above.

The timber frame that provides the skeleton of the Hempcrete wall has to be attached to the concrete posts and beams. 'Keys' or ties need to be fitted to the concrete surface, making sure the Hempcrete adheres to its surface. A stipple coat or key coat made of NHL or cement applied to the concrete will help with the adhesion of the Hempcrete infill. Consult your renderer about the joint between the concrete and Hempcrete. A 10mm joint filled with a sealant needs to be created between the last render coat covering Hempcrete and concrete.

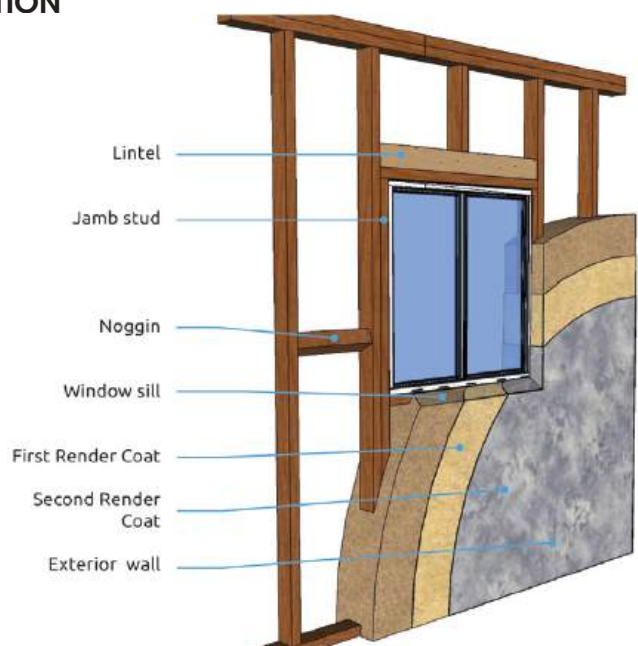

*Hempcrete wall/window detail*

## 14.m. WINDOW AND DOOR OPENINGS

As per NCC 2022 Volume 2 H1D8 requirements; door and window frames must be fastened to the building frames. Both window and door frames can be fitted in the middle, close to the inside of the wall or when a big internal sill is required, closer to the outside of the wall. The frame work securing the window might have to be brought in to or out from the main wall studs accordingly.

Metal, stone, concrete or hardwood timber window sills can be fitted, or the runoff sill can be created with render, preferably with a sealant for that surface. Water should not be able to pool anywhere and should run away from the windows. Most windows are fitted with condensation escape grooves. Allow these grooves to expel their condensation onto the outer sill. Consult with your window manufacturer what type of frame or flanges are required and how the waterproofing of the windows is guaranteed. Then talk to the renderer to have a clear understanding how the finish is created between the window, sill and Hempcrete wall.

Protect the frames from Hempcrete and render stains with the appropriate coatings and tape.

Any hardwood exposed to the elements extruding or close to walls, such as rafters, deck joists and window sills can leach their tannins over the render coats.

Timber should be de-tanned with products such as 'Deck Clean' prior to Hempcrete installation.

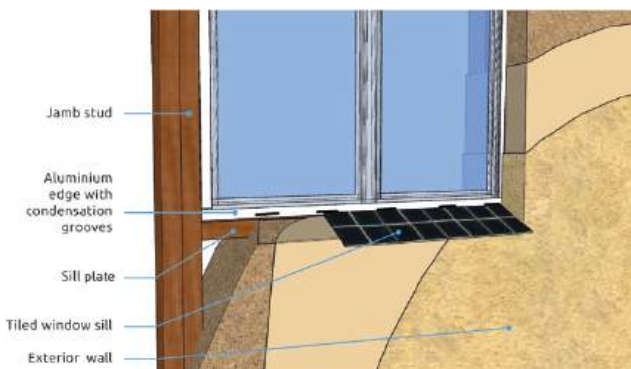

Tiled window sill detail

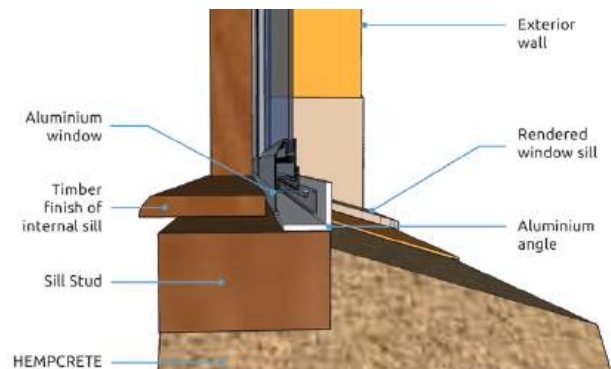

Window sill detail 1

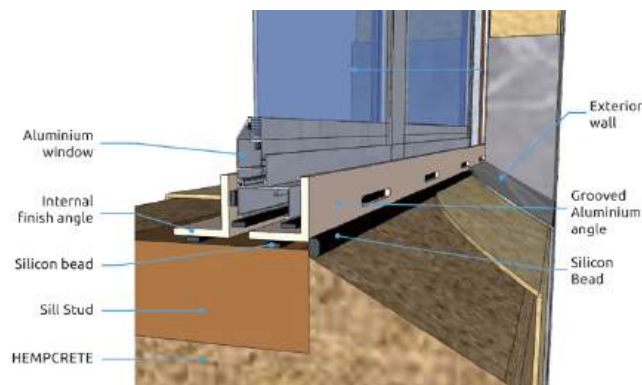

Tiled window sill detail 2

## 14.n. FIXING LOADS TO Hempcrete WALLS

Just like timber frame walls fitted with plasterboard, loads such as kitchen cupboards, basins, brackets for driers, toilet systems and the like, the frame will have to carry its loads. Therefore, during the framing of the wall, the noggins are placed at the appropriate height where the long screws are connected that carry the load. These noggins will have a minimum coverage of 70mm Hempcrete.

Masonry plugs, galvanised or stainless-steel bugle head screws can be used to hang lighter loads.

**Caution** Be sure not to penetrate services under the Hempcrete surface.

## 15. Creating Hempcrete Walls

Recommended thickness: 250 - 350 mm.



Tradical® Binder PF70



Tradical® Binder Thermo



Chanvribat® Building Hemp Shiv



Kanabat® Building Hemp Shiv



Hempflax® Building Grade Hemp Shiv

### 15.a. INSULATING WALL MIX

This is the standard Hempcrete mix used for interior and exterior walls;

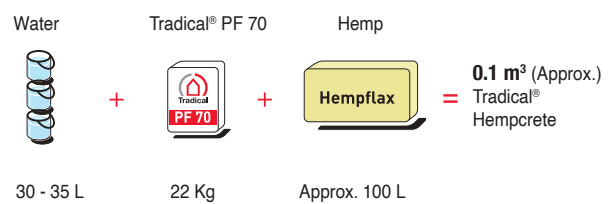
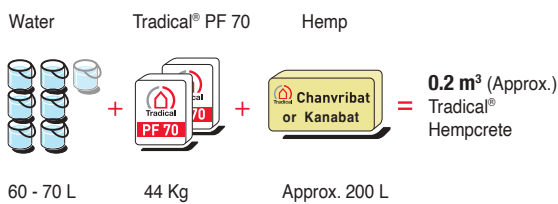

OR

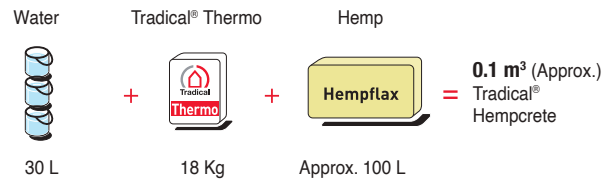
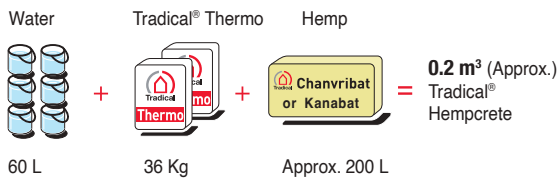

INSULATING WALL and INSULATING LINING applied between wall and shuttering		
	200L Hemp Shiv 2 bags Tradical® PF70	200L Hemp Shiv 2 bags Tradical® THERMO
<b>CHARACTERISTICS</b>		
Concrete mixed at	220 kg/m³	180 kg/m³
Mass density	320 kg/m³	280 kg/m³
Thermal conductivity	$\lambda = 0.085 \text{ W/m.k}$	$\lambda = 0.076 \text{ W/m.k}$
Compression strength (at 90 days)	0.9 MPa	0.7 MPa
<b>TRADICAL® THERMAL PERFORMANCE RATINGS</b>		
15-cm-thick wall	R = 1.8	R = 2.0
20-cm-thick wall	R = 2.4	R = 2.6
25-cm-thick wall	R = 2.9	R = 3.3
30-cm-thick wall	R = 3.5	R = 4.0
35-cm-thick wall	R = 4.1	R = 4.6
40-cm-thick wall	R = 4.7	R = 5.3
R in (m².K/W)		

## How to -

### 15.b. INSTALL Hempcrete WALL INSULATION

1. Frame needs to be inspected prior to infill.
2. Make sure that the steel clips to secure electrical conduits and plumbing are coated, ducted and affixed properly to the frame.
3. Formwork is plumb and set to the specified wall thickness. If needed check if underpinning of the floors is installed. All surfaces (including formwork) that will create the Hempcrete wall and are embedded should be made wet prior to application. The timber frame elements will extract moisture from the fresh Hempcrete.
4. **Caution** Wear gloves and eye protection. Lower arm protection in the form of a sleeve is recommended to avoid lime burns on the wrist and arms.
5. Mix up material and transport it to the formwork.
6. Tip max 200 mm layer of fresh mix in the cavity between the formwork.
7. Spread the mix evenly along a manageable length.
8. Press the material to the bottom and around the base of the frame.
9. **TAMPING:** Press the material between all cavities with a tamping tool. Keep a constant pressure on all layers. Too little tamping will result in loose parts and will have to be redone or require lots of render to fill. Tamping too hard might result in deforming or delining the formwork and a dense wall surface that consumes more material. The fresh Hempcrete will be compacted down about 10 mm. Pay attention to tamp the Hempcrete on the formwork side (new wall surface) evenly and sufficiently to form a homogeneous wall surface.
10. Cover the top Hempcrete layer with plastic or strips of insulation such as air cell products.
11. Prior to installing a new layer, scratch the surface open for better adhesion of the new layer.
12. Re-moisturise the top of the last Hempcrete layer if needed.
13. Check if your formwork has not moved. The formwork should be sound and solid at all times.
14. Apply more pressure for the first 50mm to adhere a new layer to an old.
15. Be sure not to disjoint electrical ducts or plumbing during casting.
16. Compact and smooth finished top of wall.

### 15.c. MAKING OF DAY JOINT

If you have to stop for the day with the formwork half complete, taper the last few mixes down into a gradual slope or wave (see pic at right) so that the next day your first Hempcrete is building on top of what is already there. This is better than leaving 'vertical day joints' which form a weak spot in the finished material.



## How to -

### 15.d. REPLACE / REPAIR OF Hempcrete

1. Hempcrete that is not mixed properly, is damaged by water or has lumps will need to be replaced.
2. Scratch the Hempcrete away until reaching solid material. Remove the debris.
3. Make a mix with some extra lime (20% additional lime). While the hole is little, sieve the hemp to a finer grade.
4. Dampen the cavity surface and insert approximately 30 mm layer of the fresh mix and tamp solidly to assure adhesion to the old hardened material.
5. Add layers a little at a time with firm compaction until the cavity is full.
6. Press firmly and trowel with a flat smooth surface.

### 15.e. CASTING AN INTERNAL HEMP WALL INTO AN EXTERNAL HEMP WALL

In the event of an internal hemp wall abutting an external hemp wall, ideally these walls should be cast at the same time. This allows the Hempcrete walls to dry at a similar rate. Note, the rate of drying will largely depend on both the external and internal conditions, but casting the walls at the same time ensures that the Hempcrete aggregate around the junction of the intersecting walls are locked in together at the time of casting.

Circumstances may dictate that this may not always be possible and in such cases an alternative solution would be to create a vertical rebate on the inside face of the external wall at the junction where it meets the internal (intended hemp) wall frame.

This can best be achieved by fitting a 100 x 100mm timber post running vertically from the top plate to the bottom plate which is fixed to the inside face of the formwork by screws. After the external hemp wall has been cast the screws used to hold the timber post in place on the inside face are removed as well as the post itself. The result is a 100mm wide and deep vertical groove which provides a type of locking bond when the internal wall is cast by allowing the fresh Hempcrete aggregate to fill the void. Consider it similar to a tongue and groove joint used in carpentry. Note, that 2 X 90 x 45mm studs laminated together can also be used instead of the single post.

An alternative, would be to cast a short nib wall on the internal abutting wall extending 300mm out from the external wall. It is recommended that at the end of the nib wall a 'V' joint or square groove is created along the vertical plane (ceiling to floor). This can be achieved using lengths of plywood or similar as formwork to create the shape. The 'V' joint, or square groove would provide a type of locking bond when the rest of the internal wall is cast.

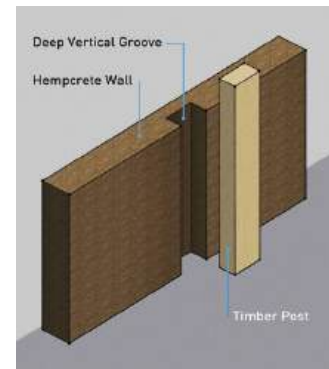

Vertical rebate example

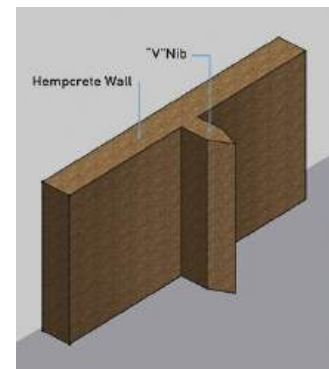

Short nib example



## 16. Roof and Floors

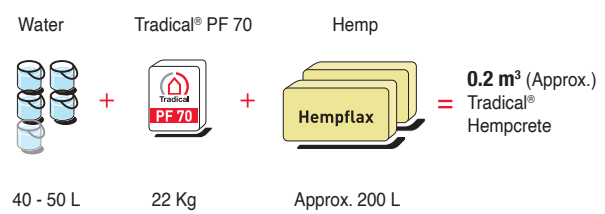
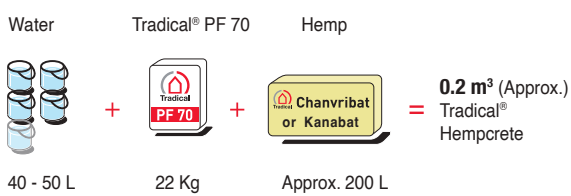

This is the lightweight Hempcrete mix used for roof and floor cavities. This mix has only enough water in it to dampen the hemp and allow the binder to mix with the hemp. It is meant to be a very dry mix with enough binder to make sure the hemp particles are covered with the binder.

### 16.a. THE ROOF MIX:

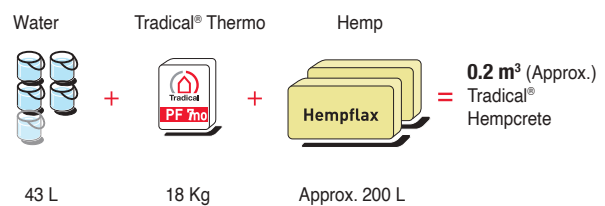
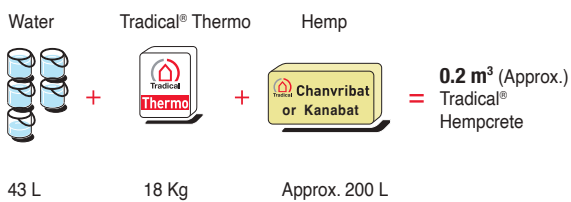

OR



INSULATING ROOF and UNUSED ROOF SPACE			
		200L Hemp Shiv 1 bag Tradical® PF70	200L Hemp Shiv 1 bag Tradical® THERMO
CHARACTERISTICS			
Concrete mixed at	110 kg/m <sup>3</sup>	90 kg/m <sup>3</sup>	
Mass density	210 kg/m <sup>3</sup>	190 kg/m <sup>3</sup>	
Thermal conductivity	$\lambda = 0.06$ W/m.k	$\lambda = 0.056$ W/m.k	
TRADICAL® THERMAL PERFORMANCE RATINGS			
20-cm-thick insulation	R = 3.3	R = 3.6	
25-cm-thick insulation	R = 4.1	R = 4.5	
30-cm-thick insulation	R = 5	R = 5.4	
35-cm-thick insulation	R = 5.8	R = 6.3	
R in (m <sup>2</sup> .K/W)			

## How to -

### 16.b. INSTALL Hempcrete ROOF INSULATION

1. Make sure that electrical conduits and plumbing are affixed properly to the frame.
2. **Caution** Ceiling lights such as down lights need space around the elements that cause heat. Please refer to NCC 2022 requirements. Notify the electrician.
3. Formwork should be able to hold the Hempcrete weight and should be attached properly to the underside of the roof cavity, now forming the ceiling surface and set to the appropriate ceiling insulation thickness.
4. All surfaces (including formwork) should dampened before application. The timber elements will extract moisture from the fresh Hempcrete.
5. **Caution** Wear gloves and eye protection. Lower arm protection in the form of a sleeve is also recommended to avoid lime burns on the arms.
6. Best practice is to apply the insulation from above before the roofing is installed.
7. Mix up material and transport it to the formwork
8. Tip max 150 mm layer of fresh mix on the ceiling formwork.
9. **TAMPING:** Spread the material gently between all cavities with a tamping tool. Keep a constant pressure on all layers.
10. Roof insulation needs to be tamped lightly only to perform maximally as an insulator. Level or screed the top layer off.
11. Cover the insulation with plastic or tarps if rain is likely to occur; keep it dry. If covered during the night, uncover the roof in the morning to let excess moisture evaporate.
12. Support the sheets holding the Hempcrete layer to avoid bulging under the weight.
13. Check if your formwork on the ceiling side has not bulged.
14. Be sure not to disjoint electrical ducts or plumbing during casting.

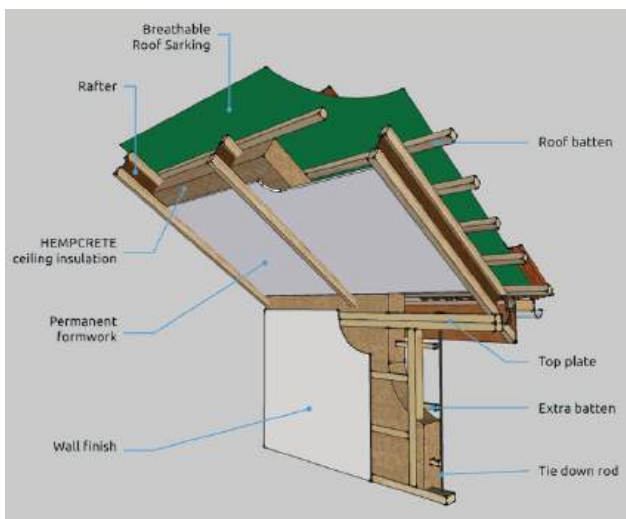

Hempcrete ceiling infill - with magnesium board permanent formwork

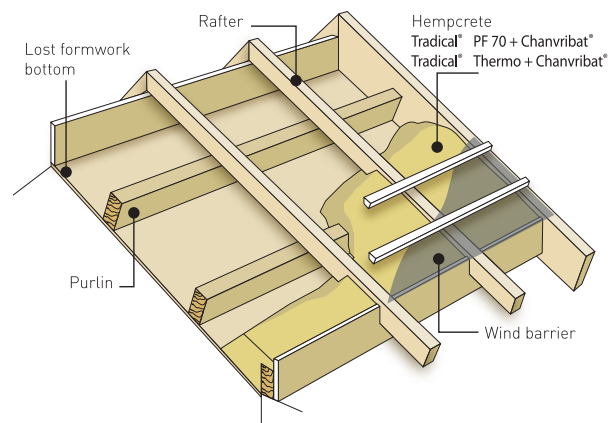

Hempcrete ceiling infill - with magnesium board permanent formwork

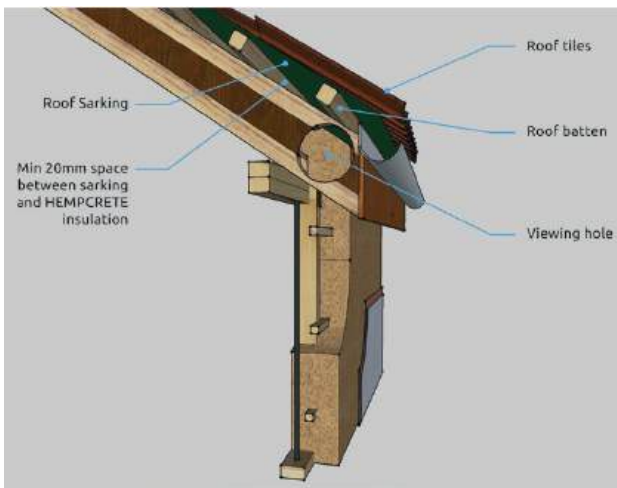

Hempcrete wall and ceiling infill junction detail 1

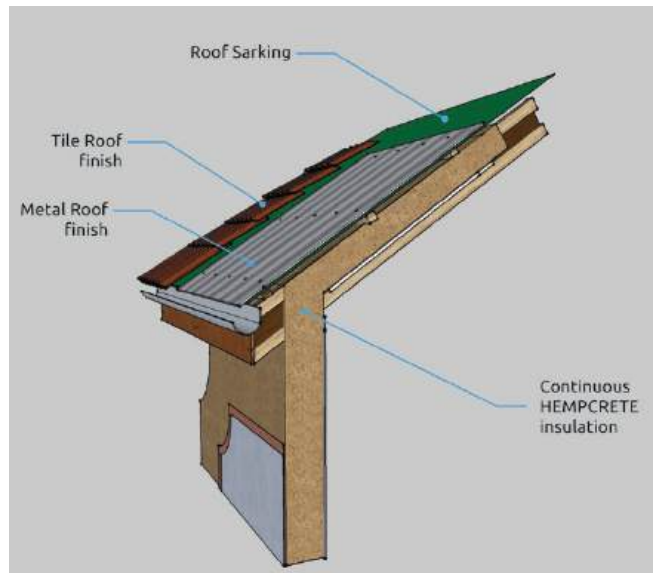

Hempcrete wall and ceiling infill junction detail 2

### 16.c. THE INSULATING FLOOR MIX

Water + Tradical® PF 70 + Hemp = 0.2 m³ (Approx.) Tradical® Hempcrete

80 - 100 L      55 Kg      Approx. 200 L

Water + Tradical® PF 70 + Hemp = 0.2 m³ (Approx.) Tradical® Hempcrete

80 - 100 L      55 Kg      Approx. 200 L



OR

Water + Tradical® Thermo + Hemp = 0.2 m³ (Approx.) Tradical® Hempcrete

80 - 100 L      45 Kg      Approx. 200 L

Water + Tradical® Thermo + Hemp = 0.2 m³ (Approx.) Tradical® Hempcrete

80 - 100 L      45 Kg      Approx. 200 L

INSULATING FLOOR		
		
	200L Hemp Shiv 2.5 bags Tradical® PF70	200L Hemp Shiv 2.5 bags Tradical® THERMO
CHARACTERISTICS		
Concrete mixed at	275 kg/m³	225 kg/m³
Mass density	375 kg/m³	325 kg/m³
Thermal conductivity	$\lambda = 0.096 \text{ W/m.k}$	$\lambda = 0.084 \text{ W/m.k}$
Compression strength (at 90 days)	1.1 MPa	0.55 MPa
TRADICAL® THERMAL PERFORMANCE RATINGS		
10-cm-thick screed	R = 1.0	R = 1.2
15-cm-thick screed	R = 1.6	R = 1.8
20-cm-thick screed	R = 2.1	R = 2.4
25-cm-thick screed	R = 2.6	R = 3.0
R in (m².K/W)		

## How to -

### 16.d. INSTALL INSULATING Hempcrete FLOOR (ON RAISED FLOOR):

1. Make sure that electrical conduits and plumbing are affixed properly.
2. Formwork should be able to hold the Hempcrete weight and should be attached properly to the underside of the joists, alternately between the webs of the I joists (confirm with the I joists manufacturer).
3. Depending on the thickness of the permanent formwork it could be necessary to install additional support with temporary struts.
4. All surfaces (including formwork) should be dampened before application. The timber elements will extract moisture from the fresh Hempcrete.
5. **Caution** Wear gloves and eye protection. Lower arm protection in the form of a sleeve is also recommended to avoid lime burns on the arms.
6. Mix up material and transport it to the formwork
7. Tip max 200 mm layer of fresh mix in the cavity between the formwork.
8. TAMPING: Spread the material gently between all cavities with a tamper tool. Keep a constant pressure on all layers.
9. Floor insulation needs to be tamped lightly only to perform maximally as an insulator.
10. Screed the top layer off just under floor level.
11. Check if your formwork on the under side of the floor side has not moved and is not bulging out.
12. Be sure not to disjoint electrical ducts or plumbing during casting.

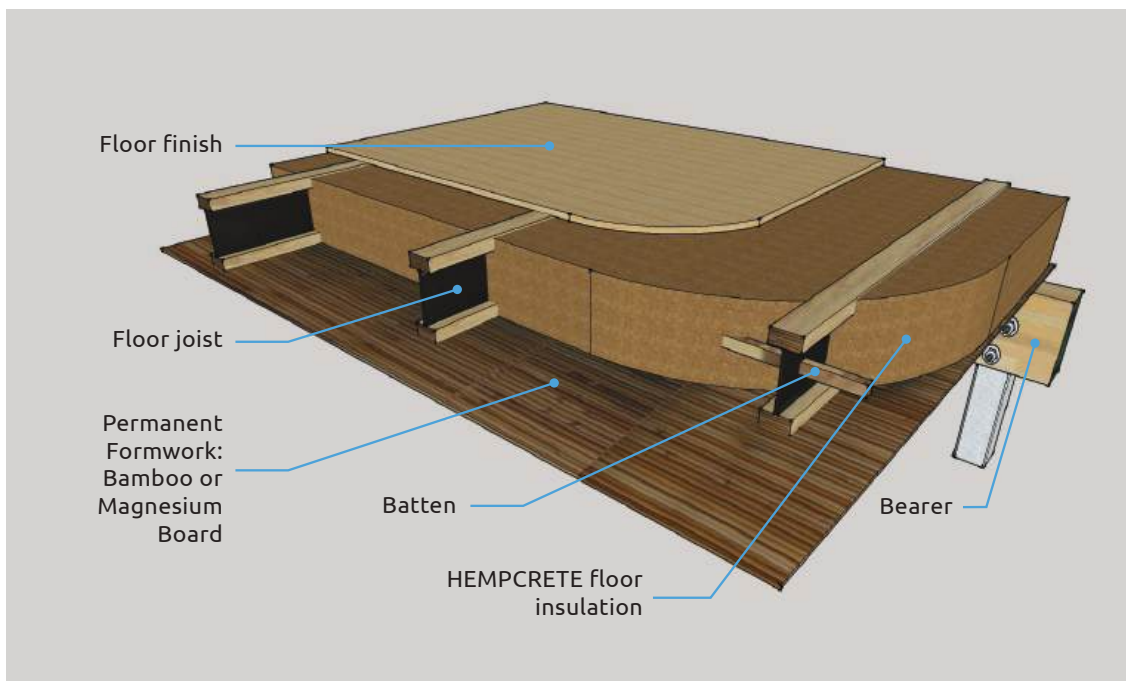

*Hempcrete floor infill - with bamboo or magnesium board permanent formwork*

The four ranges of finishes below can be applied to solid natural ground and intermediate floor:

### Flexible Flooring

On a Tradical® PF70 compression screed + sand 3 to 4cm thick.

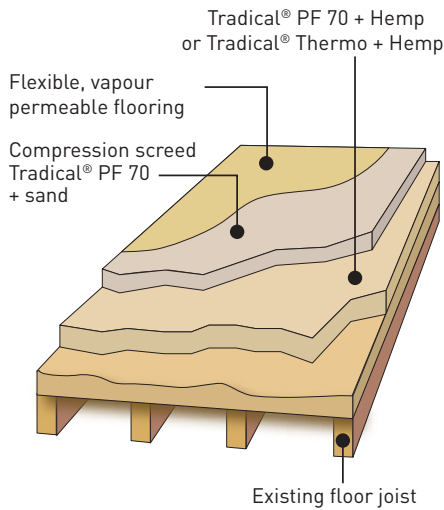

### Floorboards nailed to Floor Joists

Installed on floating floor joists on top of a thin underlay made of wood fibre panels or cork, provided that the surface is sufficiently even.

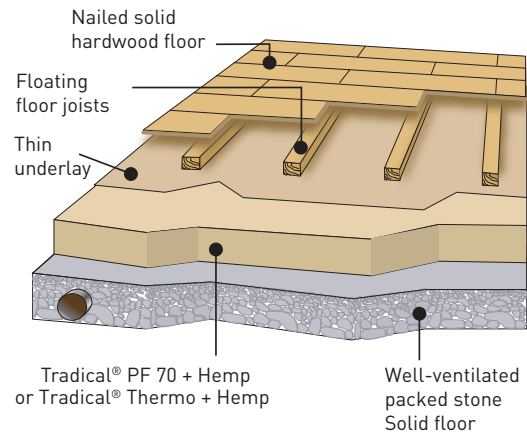

### Floating Floorboards

Directly on screed on top of a thin underlay made of wood fibre panels or cork, provided that the surface is sufficiently even.

**Note:** Flooring with insufficient compression strength must be installed on a compression screed.

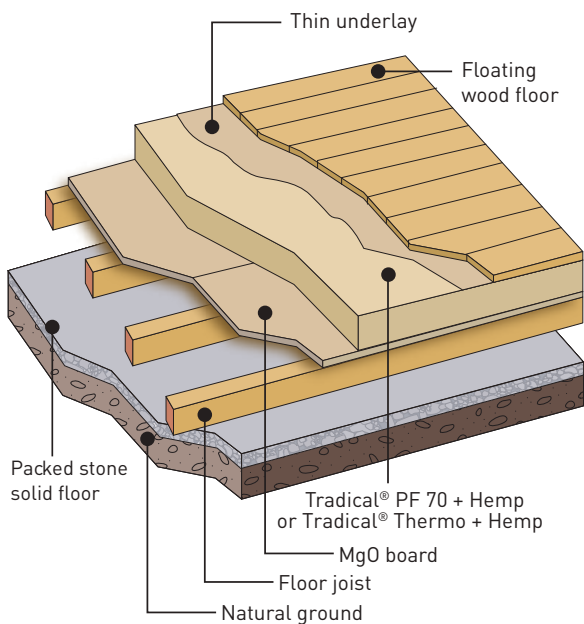

### Cemented Floor Tiles

On a Tradical® PF70 compression screed + sand 3 to 4cm thick.

### Cemented Terracotta Tiles

Slurry on wet Tradical® PF70 bonding screed + sand 3 to 4cm thick.

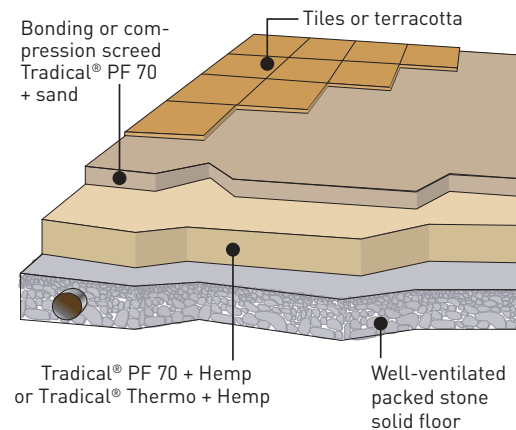

### Precautionary Measure for Application:

The minimum thickness of Tradical® Hempcrete insulating screed is 15cm. For an intermediate floor, 10cm.

#### On Wooden Floors:

Do **NOT** apply any coating that is impermeable to water vapour under the insulating screed made of Tradical® Hempcrete.

#### On Solid Ground:

Make sure that there is no risk of rising humidity and take all the necessary precautionary measures (e.g. peripheral draining and well-ventilated packed stone).

## 17. Drying of Hempcrete

---

### 17.a. DRYING

Depending on local weather conditions Hempcrete will dry between 30 and 60 days. Perhaps it is not the best to construct Hempcrete walls during the rainy season; plan ahead.

Drying is the process where moisture is released from the mix to the outer atmosphere. It can take up to 90 days. Seek manufacturer's information if in doubt.

### 17.b. BEST PRACTICE FOR DRYING:

- Ventilate the building, allow good airflow. Eventually use fans to stimulate airflow.
- Open windows and doors.
- Keep rooms with fresh Hempcrete walls open.
- Do not force dry.
- Cover walls against rain and long exposure of sunlight.
- Keep walls clear i.e. don't store anything against it.
- Mist spraying of fresh Hempcrete walls may be required, to prevent drying too fast, when:
  - temperatures are above 30°C;
  - there is direct prolonged sunshine on the walls;
  - there are strong warm winds.

### 17.c. CURING OR SETTING:

This is a different process to drying. Curing occurs when the lime bonds by a chemical reaction of the binder components. Curing happens in about 28 days.

### 17.d. CARBONISATION:

The carbonisation of the binder is a process of about five years. It will eventually result in the petrification of the Hempcrete.

**Caution** Walls and insulation made of Hempcrete need to dry properly. All the Hempcrete needs to be in a solid form throughout. When the inside of the Hempcrete walls' core is crumbly and powdery, the mix and/or application has not been right. Rectify the problem by replacing with new Hempcrete.

### 17.e. NOT PROPER DRYING:

Not proper drying of Hempcrete can lead to:

- malperformance of the insulation
- too high a moisture content in the wall
- render not drying properly for an extended period of time
- bleeding of tannins of the Hempcrete through render
- rotting of the frame

Things that will stop proper drying:

- Mix made too wet.
- Formwork in place too long.
- Rain soaked onto top of the wall / ceiling insulation.
- Rain soaked into wall from a leak.
- Condensation of covers.
- Not enough ventilation.

## 18. Rendering and Cladding

Hempcrete walls can be rendered or clad after sufficient drying.

### 18.a. RENDERING AND CLADDING MATERIALS OF EXTERNAL WALLS:

- Render
- Timber Weather board

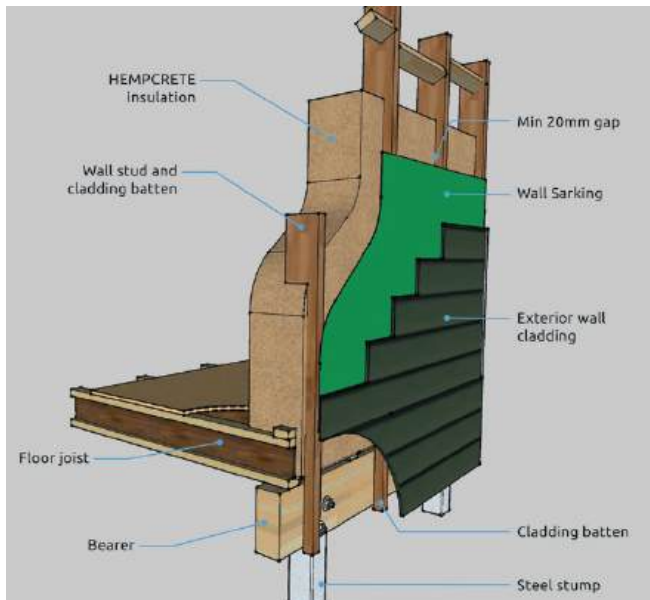

*Hempcrete wall and floor - with chamfer board cladding*

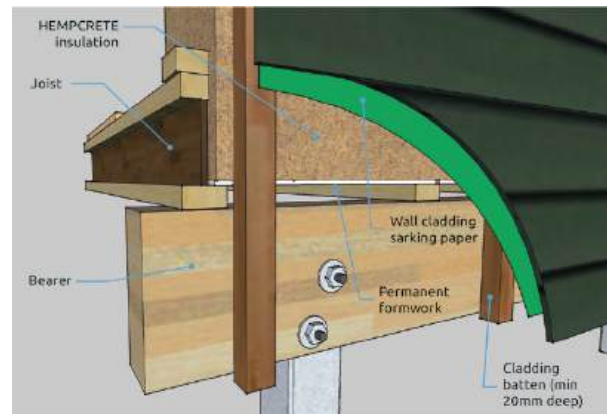

*Hempcrete wall and floor - with chamfer board cladding detail*

### 18.b. RENDERING AND CLADDING MATERIALS OF INTERNAL WALLS:

- Clay and or Lime Render
- Lime washes
- Lime paints (onto a coat of render)
- Timber tongue and groove

Render that is applied directly onto the Hempcrete wall needs to be vapour permeable at all times.

Application of non-vapour permeable wall coating will lead to moisture build up, deterioration and mould forming.

The render needs a water resistance factor of at least WP 0.85.

As per NCC 2022 Volume 2 H2D6 requirements, to be sound and installed according to termite protection regulations.

Ventilation is essential between the cladding and the Hempcrete wall. This can be achieved by a ventilation gap of at least 20mm. This gap should preferably be open on the bottom and protected from vermin with mesh.

The cladding can be attached to battens which are fastened to the Hempcrete wall with long galvanised, plastic coated (climacoat used for treated pine) or stainless screws, preferably into the framework. Glue such as liquid nails can be used.

**Caution** Make sure screws do not penetrate services such as water and electricity.

## 19. Hempcrete Render

### 19.a. THE Hempcrete RENDER MIX

Internal and External walls that require good insulation and sound regulation can be fitted with a layer of Hempcrete render.

Substrates can be concrete block, cob, stone, aerated concrete, brick etc.

There are two types of Hempcrete render;

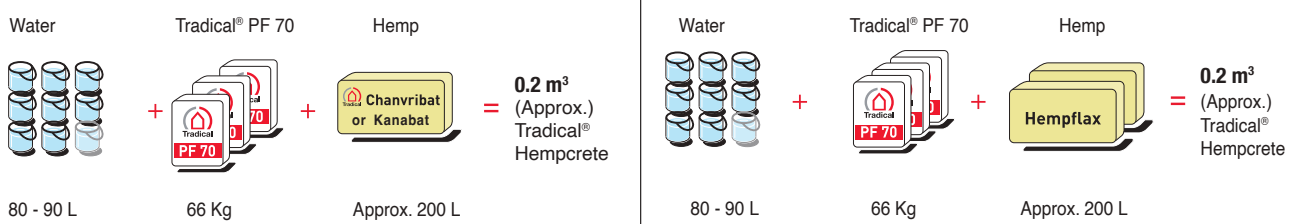

- Insulation layer of Hempcrete (render)
- Render with hemp added to the mix

The Insulating Hemp Render Mix:

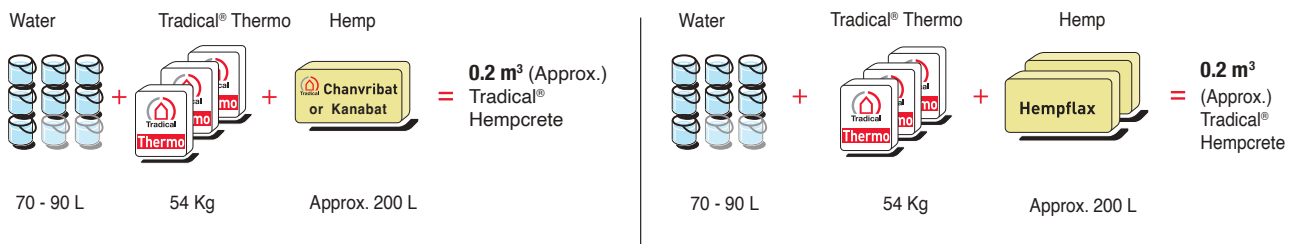

OR



INSULATING RENDER applied by trowelling		
		
	200L Hemp Shiv 3 bags Tradical® PF70	200L Hemp Shiv 3 bags Tradical® THERMO
CHARACTERISTICS		
Concrete mixed at	330 kg/m <sup>3</sup>	270 kg/m <sup>3</sup>
Mass density	430 kg/m <sup>3</sup>	370 kg/m <sup>3</sup>
Thermal conductivity	$\lambda = 0.107 \text{ W/m.k}$	$\lambda = 0.092 \text{ W/m.k}$
TRADICAL® THERMAL PERFORMANCE RATINGS		
10-cm-thick lining	R = 0.9	R = 1.09
15-cm-thick lining	R = 1.4	R = 1.63
20-cm-thick lining	R = 1.9	R = 2.17
25-cm-thick lining	R = 2.3	R = 2.72
<b>R in (m<sup>2</sup>.K/W)</b>		



## Weather-proofing of Hempcrete

Protection from precipitation loading for hempcrete wall comes from the final rendering and cladding material applied to the exterior face of the wall, or a combination of the cladding material and a protective coating (typically render/paint). Where plaster applied directly to the hempcrete wall is to be the finished exterior surface, it is possible with the use of water repellent plaster.

*Tests for water penetration were carried out by BRE Scotland on a rendered hemp-lime walls 200 mm thick. A rotary spray apparatus was employed to spray water levels similar to one years worth of wind-driven rain at a severely exposed location, or five years elsewhere, over a 96-hour period. At the end of the water spray test, water absorption was observed within the hemp walls to an average depth of 50 – 70 mm depth...the test simulates severe exposure and massive water application over a short period with positive results.*

Tradical® PF80 is a pre-formulated aerial lime binder for rendering and pointing, suitable for mixing with aggregates (sand) and water to use for hempcrete to form a traditional base coat, brown coat and single-mass render. Tradical® PF 80 Lime Render is water-repellent and will sufficiently resist water penetration to preserve permeable walling constructions such as hempcrete, while ensuring the performance of your hempcrete wall.

### Protecting Insulating walls - EXTERIOR

Coat the structure once the wall has dried.

Drying time: About 1 week for 2 cm, depending on the weather conditions.

Apply a traditional base coat and Tradical® PF 80 with water repellent properties aerial lime finish.

### Protecting Insulating walls - INTERIOR

Once the lining has dried evenly (drying time – about 1 week for 2 cm) and depending on the evenness of the surface, apply either of the following:

- a traditional lime render consisting of Tradical® PF80/Batir + 90 to 100l of sand
- a hemp render consisting of Tradical® PF80/Batir + hemp



Render finish with Hempcrete

### How to -

#### 19.b. INSTALL Hempcrete RENDER BY TROWELING - UP TO 50 MM

1. Trowel a base coat onto the substrate. The base coat is made of 1 Bag of TRADICAL® PF 70 + 60 Litres of 0/4 sand or 1 Bag of TRADICAL® THERMO + 60 Litres of 0/4 sand
2. After 24 to 48 Hours wet the surface.
3. Mixing can be done in a barrel mixer:
  - 3.(a) Add the water content.



- 3.(b) Add the TRADICAL®PF80 mix until homogeneous (3 - 5 min).
- 3.(c) Add broken up Hemp.
- 3.(d) Mix slowly until all aggregates are entirely and evenly coated, by adjusting the quantity of water if necessary.  
Use the Tradical® Hempcrete as soon as the mixture is perfectly homogeneous making sure to avoid excessive mixing.
4. Transport the mix to the formwork.
5. Trowel the lining in 2 layers.
6. Each layer is applied after the previous has hardened without exceeding a 12 to 24-hour period between each layer.
7. Smooth and trowel after each application.

## How to -

### 19.c. INSTALL HEMP INSULATION (RENDER) WITH FORMWORK - FROM 50 MM TO 200 MM

1. Trowel a base coat onto the substrate. The base coat is made of 1 Bag of TRADICAL®PF 70 + 60 Litres of 0/4 sand or 1 Bag of TRADICAL® THERMO + 60 Litres of 0/4 sand.
2. For a Hempcrete layer up to 100 mm affix timber battens with a dove tail or T shape to the wall to create a key for the Hempcrete.
3. When the total added Hempcrete layer will exceed 100 mm, place a framework to give solidity to the additional wall thickness. The frame can consist of 50 x 50 mm pine.
4. Place DPC on lowest surface to ground.
5. For external walls create a 150-mm concrete or brick wall from the FGL.
6. Install termite control measures, consult your pest control installer.
7. After 24 to 48 hours wet all the surfaces.
8. Mix the Hempcrete preferably in a pan mixer. See chapter 10 Mixing, page 14.
9. Transport the mix to the formwork and introduce the Hempcrete between the formwork.
10. Tamp the material firmly but not excessively.
11. Finish External walls with two layers of render as for external Hempcrete walls.

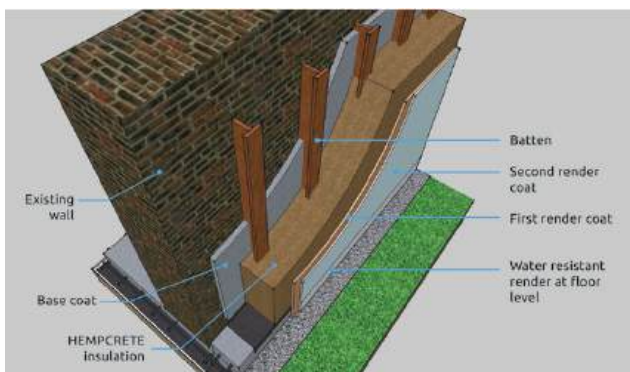

Brick wall - with exterior Hempcrete insulation

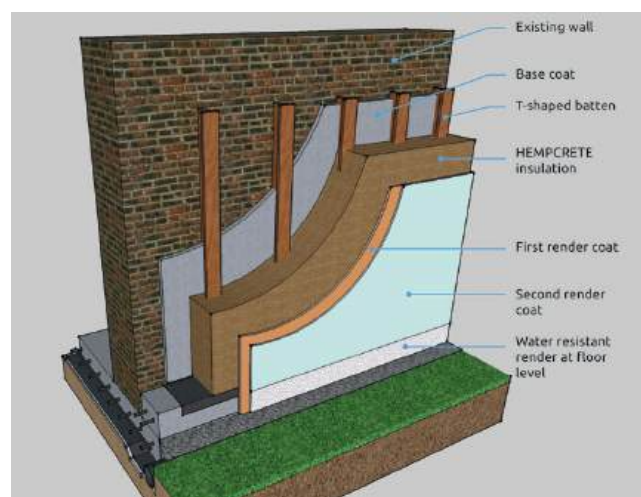

Brick wall - with exterior Hempcrete insulation

## 19.d. HYGROTHERMAL HEMP RENDER

The Hygrothermal Hemp Render Mix - Creamy Texture:

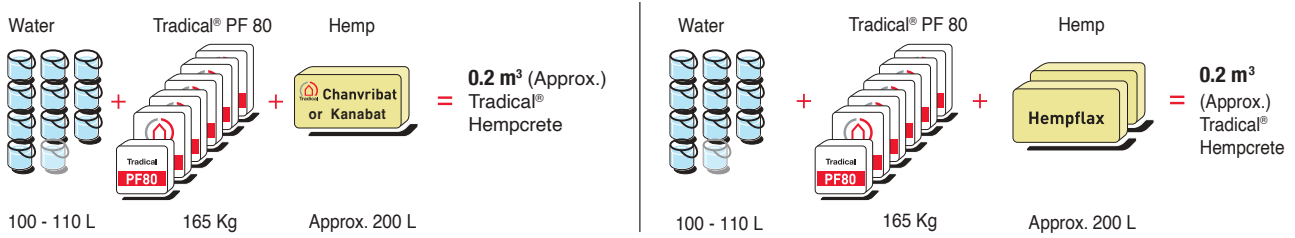

The Hygrothermal Hemp Render Mix - Standard Texture:

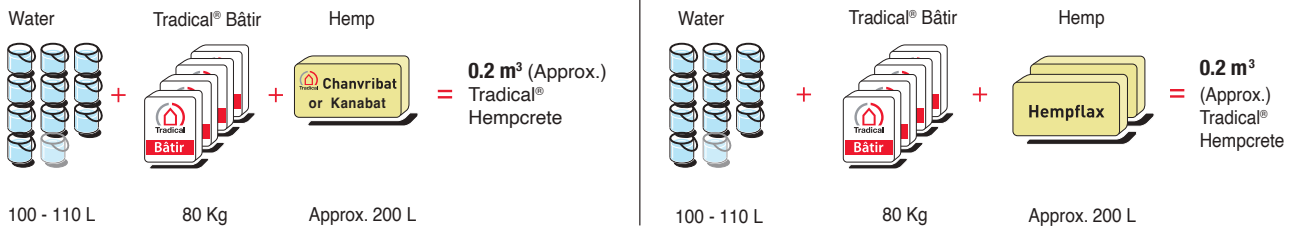

HYGROTHERMAL RENDER		
	200L Hemp Shiv 5.5 bags Tradical® PF80	200L Hemp Shiv 4 bags Tradical® Bâtir
<b>CHARACTERISTICS</b>		
Concrete mixed at	825 kg/m <sup>3</sup>	400 kg/m <sup>3</sup>
Mass density	925 kg/m <sup>3</sup>	500 kg/m <sup>3</sup>
Thermal conductivity	$\lambda = 0.17$ W/m.k	$\lambda = 0.14$ W/m.k
<b>TRADICAL® THERMAL PERFORMANCE RATINGS</b>		
3-cm-thick render	R = 0.17	R = 0.21
5-cm-thick render	R = 0.29	R = 0.36
8-cm-thick render	R = 0.47	R = 0.57
<i>R in (m<sup>2</sup>.K/W)</i>		

### Mixing method

Mixing can be performed in a concrete mixer. Add the following in this order:

- 1 Water: all at once.
- 2 Tradical® PF80 or Tradical® Bâtir: mix until a homogeneous paste is obtained (3 to 5 min).
- 3 Add broken up Hemp as the aggregate.
- 4 Mix slowly until all aggregates are entirely and evenly coated, by adjusting the quantity of water if necessary.

The mortar can be used immediately, but it will be easier to use after letting it rest for about 5 min (better adherence).

The consistency of the mortar can be adjusted by adding water progressively, as and when it is used, depending on application conditions (substrate, desired thickness, speed of execution, atmospheric conditions, etc.).

## Technical qualities

- Tradical® Hygrothermal render is a hemp render with insulating properties.
- It can be applied indoors and outdoors, on all kinds of clean and sound substrates, and is compatible with a wide variety of finishes.
- Lightweight insulating render 925 kg/m<sup>3</sup> with Tradical® PF80 500 kg/m<sup>3</sup> with Tradical® Bâtir.

## Performance

- Rectifies highly uneven surfaces.
- Used as brown coats on materials exhibiting low mechanical strength.
- Considerably improves thermal comfort, by increasing surface heat and controlling humidity, especially on cold walls.
- Considerably improves acoustics through absorption.
- Improves thermal inertia.

### Base coat on smooth masonry substrates

1 bag of Tradical® PF80 + 40l of 0/4 sand or With Tradical® Bâtir + 0/4 sand mixed as per the substrate (see technical data sheet).

Hygrothermal render is applied at least 48 hours after applying the base coat.

Before applying the brown coat, either of the following must be performed on the base coat:

- 1 Wet it, or throw on a bonding slurry (mixed with 25 litres of water for 1 bag of Tradical® PF80) as the render work progresses.
- 2 The render is applied in several successive layers 2 to 4 cm thick.

Each layer is applied after the previous one has hardened without exceeding a 12 to 24-hour period between each layer.

- 3 The first layer must be thrown on with a trowel. Subsequent layers are either thrown on with a trowel or applied with a float.
- 4 Smooth and trowel after each application.

## 19.e. LIME RENDER

**Interior render:** Depending on the desired finished appearance

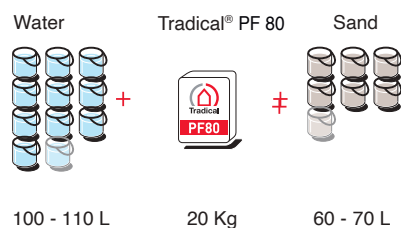

### INTERIOR:

Lime	Aggregate mix proportion
1 bag Tradical® Bâtir	+ 90 to 100 L of 0/4 sand, for <b>manual</b> application
	+ 60 to 70 L of 0/4 sand, for <b>mechanical</b> application

**Interior render:** Depending on the desired finished appearance.

Lime	Application	Aggregate mix proportion
1 bag Tradical® Bâtir	On soft or firm substrates	+ 60 to 70 L of 0/4 sand, for <b>manual</b> application
	On hard substrates	+ 50 to 60 L of 0/4 sand, for <b>manual</b> application
1 bag Tradical® Bâtir	On soft substrates	+ 55 L of 0/4 sand, for <b>mechanical</b> application
	On firm or hard substrates	+ 50 L of 0/4 sand, for <b>mechanical</b> application

**Exterior render:** Must be finished with traditional lime render with water repellent properties such as:

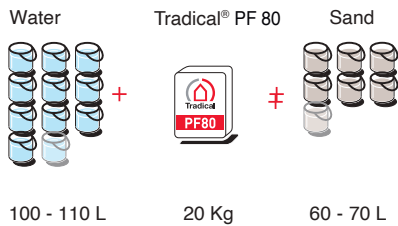

**EXTERIOR:**

Lime	Aggregate mix proportion
1 bag Tradical® PF 80	+ 90 to 100 L of 0/4 sand, for <b>manual</b> application
	+ 60 to 70 L of 0/4 sand, for <b>mechanical</b> application

Tradical® Bâtir when used as exterior renders must be finished with traditional lime render such as Tradical® PF80 or approved vapour permeable water repellent render.

HEMP RENDER RANGE		Tradical® PF 80	Tradical® Bâtir	Tradical® Décor
<b>Product description</b>		<ul style="list-style-type: none"> <li>Formulated air lime with a mineral content enabling aggregate coating and bonding.</li> <li>This white lime is used with Chanvriba® to prepare a hygrothermal render with a creamy finishing texture.</li> </ul>	<ul style="list-style-type: none"> <li>Class FL A 3.5 air lime according to standard NF EN 459.</li> <li>This white lime is used with Chanvriba® to prepare a hygrothermal render with a standard finishing texture.</li> </ul>	<ul style="list-style-type: none"> <li>Under the conditions prescribed by standard NF EN 459.</li> <li>Thin aerial lime render for interior smoothing and finishing, 80 colours</li> </ul>
<b>Ingredients</b>		<b>Technical Data</b>		
		Mineral fillers unfired limestone (CaCO <sub>3</sub> ) with well-graded particle size distribution	Air lime with 98% Ca(OH) <sub>2</sub>	Air lime
		TRADICAL® PF 80 binder - Air lime with a 98% of Ca(OH) <sub>2</sub>	Hydraulic binder	Hydraulic binder
		35%	80%	80%
		65%	20%	20%
		84%		
		16%		
<b>Apparent mass density</b>		0.85	0.61	Density < 1.16 +/- 0.05 kg/dm <sup>3</sup> Particle size distribution: 1 mm
<b>Packaging</b>		20 kg paper bag on 40-bag pallet	20 kg paper bag on 50-bag pallet	25 kg paper bag on 40-bag per pallet
<b>Weight of one pallet</b>		1200 kg	1000 kg	1000 kg
<b>Pallet dimensions</b>		150H x 90L x 110W	110H x 120L x 110W	H x L x W = 110 x 120 x 120
<b>Storage</b>		Unexposed and dry	Unexposed and dry	Unexposed and dry

## 20. Render

The following are guidelines only. Please consult with your renderer.

**Caution** Mesh of ALL rendered surfaces is recommended with emphasis on corners, above lintels and openings etc.

The substrate must not contain more than 15% moisture (WME) prior to applying finishing renders.

It is very important to prepare the hempcrete wall prior to rendering. The substrates must be moistened until saturation point the day before, re-moistened if required, and left to dry.

Any imperfection in the substrates must be repaired prior.

### 20.a. INTERIOR AND EXTERIOR RENDER

Interior Hempcrete walls can be finished with a scratch/base coat of either Tradical® PF70 plus 60 Litres of (0/4mm) sand or Tradical® Thermo plus 60 Litres of (0/4mm) sand.

Follow a week later, when the base coat is sufficiently dried out, with Tradical® Batir plus 60 Litres of (0/4mm) sand.

Exterior Hempcrete walls need to be protected against weather and finished with a scratch/base coat of either Tradical® PF70 plus 60 Litres of (0/4mm) sand or Tradical® Thermo plus 60 Litres of (0/4mm) sand.

And a week later, when the base coat is sufficiently dried out, finish with 1 bag Tradical® PF80 plus 60-90 Litres of (0/4mm) sand.

Tradical® PF80 has water repellent properties suitable for external and wet area uses.

You may finish with Tradical® PF70 and the finished colour will be grey, whereas Tradical® Batir and Tradical® PF80 finishes white. Tradical® PF80 has water repellent properties and Tradical® Batir is without.

### 20.b. AESTHETICAL RENDER – FINISHING COAT

Tradical® Décor can be used for aesthetic effect, Tradical® Décor is a thin ready-to-mix aerial lime render suitable for interior smoothing and finishing in 1 or 2 coats, available in 80 colour finishes.

#### Smoothing

- Spread the Tradical® Décor using the finishing trowel to an even thickness of 3 to 5 mm.
- Leave to dry for at least 3 days before applying the finishing coat.

#### Finishing

- On the day before application, wet the smoothing area. If necessary, cool before application.
- Spread the Tradical® Décor using the finishing trowel to an even thickness of 2 to 3 mm.
- Use the float or finishing trowel as required to achieve the desired finish.

Usage: approx. 1.2kg/m<sup>2</sup>/mm

Mix proportion	Application	Yield per m <sup>2</sup>	Yield per 25kg bag	Thickness
1 Coat		3.6 to 6 kg	4 to 7 m <sup>2</sup>	3 to 5 mm

2 Coats	Smoothing	3.6 to 6 kg	4 to 7 m <sup>2</sup>	3 to 5 mm
	Finishing	2.5 to 3.6 kg	7 to 10 m <sup>2</sup>	2 to 3 mm

## How to -

### 20.c. MIX RENDER

1. Introduce water into mixer or bucket.
2. Add the binder.
3. Allow mixing for 3-5 minutes until homogenous.
4. Add the sand and mix for 5-10 minutes until homogeneous mix, uniform colour.
5. This mix should be smooth and fat. Mineral pigments can be added to the final coat.
6. **Caution** Wear PPE to protect airways, skin and eyes. Lime is caustic. See safety.



*Render finishes*

## 21. Preservation of Hempcrete Walls and Renders

---

Renders can be cleaned with a brush and thinned soapy water mix.

Inspect if renders are solid and sound. Repair cracks immediately. Repair leaks in downpipes that flow onto the rendered surfaces to avoid the render washing away. Check if the termite barriers are still in place. Avoid pooling of water on render at any time.

# MIXING QUICK REFERENCE GUIDE

## 1. THE LOW DENSITY (STANDARD) WALL MIX

Water + Tradical® PF 70 + Hemp = **0.2 m³ (Approx.)** Tradical® Hempcrete

60 - 70 L      44 Kg      Approx. 200 L

Water + Tradical® PF 70 + Hemp = **0.1 m³ (Approx.)** Tradical® Hempcrete

30 - 35 L      22 Kg      Approx. 100 L

OR

Water + Tradical® Thermo + Hemp = **0.2 m³ (Approx.)** Tradical® Hempcrete

60 L      36 Kg      Approx. 200 L

Water + Tradical® Thermo + Hemp = **0.1 m³ (Approx.)** Tradical® Hempcrete

30 L      18 Kg      Approx. 100 L

## 2. THE INSULATING ROOF MIX

Water + Tradical® PF 70 + Hemp = **0.2 m³ (Approx.)** Tradical® Hempcrete

40 - 50 L      22 Kg      Approx. 200 L

Water + Tradical® PF 70 + Hemp = **0.2 m³ (Approx.)** Tradical® Hempcrete

40 - 50 L      22 Kg      Approx. 200 L

OR

Water + Tradical® Thermo + Hemp = **0.2 m³ (Approx.)** Tradical® Hempcrete

43 L      18 Kg      Approx. 200 L

Water + Tradical® Thermo + Hemp = **0.2 m³ (Approx.)** Tradical® Hempcrete

43 L      18 Kg      Approx. 200 L

## 3. THE INSULATING FLOOR MIX

Water + Tradical® PF 70 + Hemp = **0.2 m³ (Approx.)** Tradical® Hempcrete

80 - 100 L      55 Kg      Approx. 200 L

Water + Tradical® PF 70 + Hemp = **0.2 m³ (Approx.)** Tradical® Hempcrete

80 - 100 L      55 Kg      Approx. 200 L

OR

Water + Tradical® Thermo + Hemp = **0.2 m³ (Approx.)** Tradical® Hempcrete

80 - 100 L      45 Kg      Approx. 200 L

Water + Tradical® Thermo + Hemp = **0.2 m³ (Approx.)** Tradical® Hempcrete

80 - 100 L      45 Kg      Approx. 200 L



# MIXING QUICK REFERENCE GUIDE

## 4. THE INSULATING RENDER MIX

Water + Tradical® PF 70 + Hemp = 0.2 m<sup>3</sup> (Approx.) Tradical® Hempcrete

80 - 90 L      66 Kg      Approx. 200 L

Water + Tradical® PF 70 + Hemp = 0.2 m<sup>3</sup> (Approx.) Tradical® Hempcrete

80 - 90 L      66 Kg      Approx. 200 L

OR

Water + Tradical® Thermo + Hemp = 0.2 m<sup>3</sup> (Approx.) Tradical® Hempcrete

70 - 90 L      54 Kg      Approx. 200 L

Water + Tradical® Thermo + Hemp = 0.2 m<sup>3</sup> (Approx.) Tradical® Hempcrete

70 - 90 L      54 Kg      Approx. 200 L

## 5a. THE HYGTROTHERMAL RENDER - CREAMY TEXTURE

Water + Tradical® PF 80 + Hemp = 0.2 m<sup>3</sup> (Approx.) Tradical® Hempcrete

100 - 110 L      165 Kg      Approx. 200 L

Water + Tradical® PF 80 + Hemp = 0.2 m<sup>3</sup> (Approx.) Tradical® Hempcrete

100 - 110 L      165 Kg      Approx. 200 L

## 5B. THE HYGTROTHERMAL RENDER - STANDARD TEXTURE

Water + Tradical® Bâtir + Hemp = 0.2 m<sup>3</sup> (Approx.) Tradical® Hempcrete

100 - 110 L      80 Kg      Approx. 200 L

Water + Tradical® Bâtir + Hemp = 0.2 m<sup>3</sup> (Approx.) Tradical® Hempcrete

100 - 110 L      80 Kg      Approx. 200 L

## 6. THE LIME RENDER

Water + Tradical® Bâtir + Sand = 0.2 m<sup>3</sup> (Approx.) Lime Render

100 - 110 L      20 Kg      60 - 90 L

### INTERIOR:

Lime	Application	Aggregate mix proportion
1 bag Tradical® Bâtir	On soft or firm substrates	+ 60 to 70 L of 0/4 sand, for <b>manual</b> application
	On hard substrates	+ 50 to 60 L of 0/4 sand, for <b>manual</b> application
1 bag Tradical® Bâtir	On soft substrates	+ 55 L of 0/4 sand, for <b>mechanical</b> application
	On firm or hard substrates	+ 50 L of 0/4 sand, for <b>mechanical</b> application

Water + Tradical® PF 80 + Sand = 0.2 m<sup>3</sup> (Approx.) Lime Render

100 - 110 L      20 Kg      60 - 70 L

### INTERIOR:

Lime	Aggregate mix proportion
1 bag Tradical® Bâtir	+ 90 to 100 L of 0/4 sand, for <b>manual</b> application
	+ 60 to 70 L of 0/4 sand, for <b>mechanical</b> application

### EXTERIOR:

Lime	Aggregate mix proportion
1 bag Tradical® PF 80	+ 90 to 100 L of 0/4 sand, for <b>manual</b> application
	+ 60 to 70 L of 0/4 sand, for <b>mechanical</b> application



## CONTACTS

### OzHemp

PO Box 2204, Kardinya,  
Western Australia 6163

**Phone:** +61 8 6424 8262

**Fax:** +61 8 6424 8782

**Email:** info@ozhemp.com.au

**www.ozhemp.com.au**

# OzHemp





### **Tradical<sup>®</sup> Hempcrete that sets the standard**

TRADICAL<sup>®</sup>PF70 is a ready-to-use pre-formulated binder combining air lime and hydraulic binders, to meet all needs in terms of building masonry, rendering and plastering in the renovation and new build market segments. TRADICAL<sup>®</sup>PF70 has been developed to make a high-quality air lime binder with controlled setting. It is the binder for building masonry with all possible wall structures, roofing, rendering and plastering in both renovation and new build constructions.

Hempflax<sup>®</sup> and Chanvribat<sup>®</sup> building grade quality hemp shiv are from specially selected, processed and certified hemp shiv (hurd) from the industrial hemp plant, suitable for use in construction and insulation hempcrete using TRADICAL<sup>®</sup> lime binder; insulating walls, roofs and hygrothermal renders, as well as brand-new constructions or renovations of all kinds: detached houses, residential buildings, public buildings, and more.

When combined together in appropriate proportions and mixed with water the resulting mixture becomes a bio-composite substitute commonly known as Tradical<sup>®</sup> Hempcrete. Tradical<sup>®</sup> Hempcrete can be used to form solid thermal walls of framed buildings and provide an excellent, vapour permeable, insulation wall form. The mixture can be cast into moulds of all shapes and sizes to form pre-cast blocks and panels both on and off site. Tradical<sup>®</sup> Hempcrete is a nonstructural, lightweight material that has vapour phase change characteristics delivering low energy buildings with the potential to achieve negative carbon footprints.



IMAGE CREDIT: D'Alo Constructions, VIC

# Benefits

- » Environmentally friendly
- » Low carbon footprint
- » Excellent insulation
- » Low thermal conductivity
- » Fully recyclable
- » Durability
- » Natural pest resistance



## Benefits of Using Hempcrete When Building Your Home

Hempcrete has significant advantages over concrete. It is vapour permeable, fire resistant and a good insulator, and can be used as an infill around a timber frame, as a finishing plaster, or to build freestanding walls.

The Hemp plant absorbs atmospheric CO<sup>2</sup> during the plant growth phase, and again as the material gains strength and matures. (100sq. m with 300mm thick walls) will lock up 7.9 tons of CO<sup>2</sup> in the walls.

Estimated rate of carbon sequestration is 165Kg CO<sup>2</sup> capture/m<sup>2</sup>. Therefore, building with Hempcrete reduces atmospheric CO<sup>2</sup>.

### Environmentally Friendly

Hempcrete is the perfect, natural building material. Being made of a mixture of water, hemp and a lime based binder; Hempcrete walls are able to absorb large amounts of CO<sup>2</sup>. This incredible attribute makes Hempcrete extremely environmentally friendly and the building material of choice for any potential house builder who possess even a modicum of concern for his children's future. If you happen to be considering building your own home then it is of vital importance that you use the most environmentally friendly building materials that you can lay your hands on.

It is not merely homes that can benefit from the use of Hempcrete in their construction. The owners of commercial properties, including shops and offices for instance, can make a considerable statement by including this material in their construction. If your organisation happens to be considering office relocation as an option, an important consideration would be the material used in the construction of your new premises. Relocating to new premises can help to breathe new life into any company, but it is also important to bear in mind the environmental impact that your new building will have.

