

# Altis



## TERMITE RETICULATION SYSTEM



## INSTALLATION AND INJECTION PROCEDURES FOR ALTIS ANTI TERMITE IRRIGATION SYSTEM – 2017 ver 5

**Please destroy all other versions**

The current version replaces all previous installation and injection procedures. Drawings are mostly indicative and used for training purposes to indicate system layout. **This manual is intended for Altis installers only. Please do not distribute to unauthorised persons.**

**PERSONS WHO ARE NOT SUITABLY QUALIFIED MUST NOT INJECT TERMITICIDE.**

**Where AS3660 appears in the text it refers to the AS 3660.1-2014**

**Installers** of the reticulation system and persons who inject termiticide into the system must be trained by Altis

This procedure is to be executed and read in conjunction with the manual and requirements of the Australian Standards Code and installers must be conversant with the details of this manual and future industry upgrades to the relevant code.

Chemicals are applied according to manufacturer's APVMA approved label. Until chemical injection has been completed this is not a viable termite Management system, systems must not be left dry. Certificates are issued to Installers but are only current while the installer is employed or is the owner of the company which signed an Altis contract when training was given. Agreements require refreshing of training for installers at regular intervals. The interval for retraining will be determined in conjunction with the installer

**Materials with faults must not be installed.** Installers are expected to be vigilant. Set aside damaged materials for replacement. When an installation is laid, but concrete is not poured, water should be injected into the system for testing for leaks.

**Storage:** - Do not store or leave the components of the system on a vehicle or any exposed position unless protected from UV and heat.

**Must not be left dry:** - It is important to keep the system moist. Therefore the system must not be left dry and pumped as soon as the slab has cured. AS3660 advises that this should be carried out after 28 days and no later than 60 days after the slab has been poured. The external perimeter can be left to be installed as soon as it is unlikely to be disturbed by other trades. Chemical should be pumped as soon as practicable after completion. The 28 day and 60 day time period also applies if concrete is poured.

## INDEX

Introduction and features.....	Page 3
Chemicals information.....	Page 9
Overview of system types .....	Page 11
Injection of all Altis systems .....	Page 32
Injection point methods .....	Page 36
Parts list and description of how they are used .....	Page 38
Construction preliminaries.....	Page 41
Addendum.....	Page 44



## **FEATURES OF THE ALTIS SYSTEM**

## **WHY ALTIS RETICULATION IS THE BEST TERMITE MANAGEMENT SYSTEM**

Chemicals kill termites, but have a limited life whereas Altis reticulation allows constant replenishment for 50 years.

ALTIS ensures that accurately designed rates of chemical are applied evenly. Traditional hand spraying achieves haphazard results and is not permitted by some local authorities and/or in some States of Australia.

Handspraying is not a replenishable system. Hand spraying provides only short-term relief but Altis provides a long term solution, with no messy spraying or drilling when retreatment is required. The system is simply re charged by an accredited pest control company.

The system provides effective replenishment with no health risk over the life of the building and will enable the use of even more environmentally safe termite control agents as they become available in the future.

Altis allows for the treatment to be replaced/recharged with no disruption and no unsightly excavation or drilling.

The cost benefit over time is considerable as recharge costs are significantly lower than a drill and trench retreatment.

Advances in chemicals can be utilised throughout the life of the system.

Altis can be used as a complete system to new constructions with the system below the floor and around the perimeter or on established buildings it can be used as an external perimeter only to complement other termite control methods and add convenience of maintenance.

Maintenance is much more convenient for the customer and the installer when pump up of new chemicals occur from as little as one fill up point.

Altis Pty Ltd is an Australian company that has patented and developed innovative technology in termite protection systems in a cost competitive, effective, replenishable variety of termite management systems, which solves the problem of effective long term termite control.

Altis is a high quality system accurately dosing termite control through controlled rate emitters (drippers) thus minimising termiticide usage, and also preventing exposure to on site workers to chemicals, spray drift to neighbours, and exposure of pets to chemicals.

The materials in the system are fully warranted for 50 years subject to annual inspections, replenishment at the intervals specified by Altis accredited licensees and applied as per chemical manufacturer's specifications.

Altis achieved Australian Building Codes Board national certification after an exacting examination of the system. This was a continuation of 13 years of development to gain the highest stamp of approval that can be given in the country. This certification scheme was discontinued and the "CodeMark" building product certification scheme has replaced the old scheme.

Such is the quality of Altis that we have been granted the CodeMark certificate of Conformity which is the highest standard of excellence that can be achieved in Australia for building products and systems.

The standards required in Australia are highly regarded throughout the world. Above all we are a long established company with many thousands of successful installations since 1995.

- We hold current CodeMark certification.
- CSIRO technical opinions 145 and 222 are available for viewing. The opinions are no longer required due to having achieved the Certificate of Conformity. However CSIRO has appraised all Altis termite reticulation (irrigation) systems as being fit for the purpose for which they were designed.
- Building Code of Australia Compliance
- Deemed to Comply Regulations
- Meets Australian Standards.
- Extensive testing of chemical distribution, outlined in our opinions, completely proves the distribution as superior in the even distribution of chemicals.
- A comprehensive engineers report demonstrates suitability in clay.
- Materials longevity and effect of termiticide on materials are tested to World standard testing; far more aggressively tested than in field conditions the results of which prove life of materials in excess of 50 years.
- Altis is a patented system with a long history of success first conceived in 1992 and in full use since 1995.

#### **THE ALTIS SYSTEM UNIQUE POINTS OF DIFFERENCE:-**

- Many systems are on the market which have a series of a holes drilled into the pipes, but Altis has scientifically designed and regulated delivery points (emitters) which ensure the correct amount of chemical is delivered to all areas being treated.
- As well as the use of flexible pipes, which are of particular advantage in difficult areas such as clay sites, Altis uses emitters to distribute chemical at a measured rate, and perforated plastic sheeting to further enhance even distribution. The termiticide is pumped in to the system at low pressure, which maintains an even distribution at all points along a pipe. Use of emitters ensures no roots from vegetation will clog the pipe and render it ineffective.



- The unique, patented difference in the Altis system is that the pipes are laid over a perforated plastic membrane, beneath the builder's membrane. In this way chemical is distributed evenly and prevents any areas being untreated, denying opportunities for termites to enter.



- Recent tests show that over a 50 metre distance there is complete and even distribution over the entire length of a single line system. No other system can match these results.
- Altis pipe is flexible too! A short video is available showing a pipe bent well past 45 degrees despite the Altis recommendation of 30 degrees maximum bend, and liquids still emit. Altis has a favourable engineers report confirming that Altis operates effectively in CLAY even if clay subsidence occurs. This is largely because of the flexibility.
- Because Altis pipe is a flat section pipe there is minimal impression on concrete slabs which can weaken the slab. The Altis pipe will crush but as soon as fluids are pumped through it changes to a round shape. The pipe pushes the substrate aside.
- Should there be any question of the soil's ability to absorb chemical or as extra precaution where circumstances require, foaming techniques can be applied.
- The Altis system is simple to install reducing the risk of installation errors.
- The Altis purple ribbon is a trademarked colour in Australia when used in an Altis Anti -Termite irrigation or reticulation system. This is appropriate because the colour indicates that the water that is not drinkable. Another Altis safety feature.
- The purple colour identifies the Altis pipe as high density, flexible, resistant to solvents used in some Termiticides, manufactured in the unique flat section that fills out under pressure, with emitters which evenly disperse emulsion under low pressure.
- All materials have been tested to the worldwide recognized American Standard testing system for resistance to solvents and long life of 50 years plus under soil.
- Our pipe emits at 2.7L/hr with emitters at 175 mm centres to give a fast pump up time even though it is a low pressure system. The 175mm spacing is scientifically measured to disperse chemical evenly when used in conjunction with a spreading material. On the underside Altis Pty Ltd is branded to authenticate the pipe.
- Most of the Materials are made in Australian and all are sourced in Australia.

## **BUILDERS and CONCRETORS ADVANTAGE**

Builders do not need to make special provisions for the Altis system during preparation for construction and concretors are not held up due to the speed at which an Altis system can be laid by a practiced installer using pre assembled materials.

Because the Altis pipe is a flat section pipe there is minimal impression on concrete slabs. Deep impressions can weaken the slab.

## **INSTALLERS ADVANTAGE**

- Test results show that over a 50 metre distance there is complete and even distribution over the entire length of the system. No other system can match these results.
- ALTIS is the ONLY system which can treat 50 lineal metres from ONE pump-up point. By use of a multiple manifold system, additional 50 metre runs or shorter can be installed. The only limitations being the capacity of the delivery pump. As most residences have less than 100 lineal metres circumference the ALTIS system can be recharged from one pump-up point. This makes for ease of recharging and also making the system less obtrusive.
- Multiple Altis lines do not need to be balanced. This means that you can run differing lengths of lines from the one manifold, simplifying calculations and making the system close to foolproof.
- Altis can be used on sites where there is a 5 metre height difference between pump up point and other sections of the site.
- Brightly coloured purple pipe (TRADEMARKED) distinguishes the system from other materials on site.
- Installation can be checked by “Mathematics” to ensure the system is operating as designed.
- Does not require trenches to lay the dripper line.
- No “socks” are needed.
- Joints are easy to use slip joints.
- Flexible ‘emitter’ ribbon (the pipe) allows easy use through undulations. E.g. thickening beams or changed slab levels.
- Materials are partially pre assembled for greater time savings on the job. Be surprised at how quickly the job goes down. There are fewer mistakes too, which translate into more profits.
- Altis is a faster installation – keeps you happy, and the builder too.
- There are very few specialised tools – only a remote control pressure unit (RCPU).
- It is a low pressure system that means you do not require a special pump.
- Pump ups are fast due to a 2.7 l/hour flow rate in emitters.

## ALTIS ADVANTAGE - WHY THE PIPE WILL NOT FLATTEN AND CEASE TO WORK.

The pipe is supplied flat and is designed to be slightly elastic so that on filling it rounds up to about the size of a garden hose and then flattens again on release of fluids.

The reason for it being flat and elastic is that it won't put a circular indentation in the builder's concrete that would happen with a rigid pipe (weakening the concrete) and has the added benefit that in a clay subsidence the elasticity means the system will continue to function.

Under trials when dried concrete was lifted during testing there were pressure marks but no more than would occur from folds in the builder's plastic membrane.

## ALTIS ADVANTAGE OF BONDING PIPE TO PERFORATED PLASTIC FOR ADDITIONAL EVEN SPREAD OF CHEMICALS.

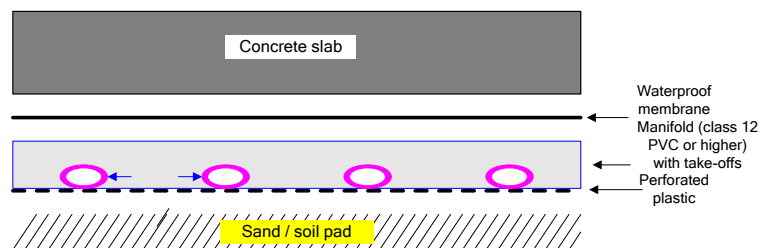

From the above illustration we see that under the slab a builder's membrane is required to prevent moisture from rising and affect the concrete slab.

The Altis pipe goes under the builder's membrane using emitters spaced 175 mm apart – the emitter faces down. The spacings are closer than needed but are part of our plan to make a better system not a barely adequate one.

Under the pipe goes the Altis pre perforated plastic membrane, which is different from the builders' membrane in that holes are provided for even chemical dispersion. The chemical leaves the pipe emitter, spreads across the plastic and drops through the Altis membrane.





## **CHEMICALS INFORMATION**

## **CHECKING THE SYSTEM PERFORMANCE -THE SYSTEM MATHS**

Checking the systems performance is easy, because of the simple “Mathematics” of the system.

The Altis pipe is fitted with EMITTERS 175mm apart.

The Emitters are rated @ 2.7 litres per hour @ 100 Kpa

Therefore: each metre of Altis pipe delivers

$1000/175 \times 2.7 = 15.42$  litres per metre @ 100 Kpa.

## **APPLICATION RATES**

The treatment rates are at the label rate of 100 litres per cubic meter of soil for treatments to perimeter locations to achieve a continuous barrier 150mm wide to a minimum vertical depth of 80mm. The vertical barrier must continue 50mm below the top of the footing. The horizontal treatment rate of 5 litres per square metre applies for areas under concrete slabs.

## **CHEMICALS**

Note due to conditions of certificate of conformity these chemicals only are to be used with no substitutes.

Bayer Premise 200SC

Syngenta Altriset

Ensystem Maxthor 100

Ensystem Ultrathor Prothor 200SC

FMC Biflex Aquamax

FMC Biflex Ultra

David Gray Bifenthrin Aqua

David Gray Bifenthrin EC

Sherwood Chemicals Fipforce Aqua

Sherwood Chemicals Imilforce 200SC

Sherwood Chemicals Biforce 100SC

Sherwood Chemicals Biforce 200SC

Sherwood Chemicals Ultraforce Aqua



## OVERVIEW OF SYSTEM TYPES

There are a range of solutions to meet varying construction methods. The following drawings cover:-

- 1. FULL UNDERSLAB**
- 2. INTERNAL PERIMETER**
  - Economy
  - 600w
- 3. PENETRATIONS**
- 4. EXTERNAL PERIMETER**
  - 150
  - Dam wall
- 5. SPECIALS**

## FULL UNDERSLAB SYSTEM

Premium under slab sheet and Altis pipe covers completely under the slab.

This system, except for smaller slabs is assembled on site. The components to be purchased comprise 1000 metre rolls of Altis pipe and 1 metre wide perforated plastic which fold out to 2 metre wide by 50 metre long. For smaller systems a pre assembled 600mm twin line pre assembled system can be purchased.

### ASSEMBLY ON SITE

#### Method.

Bulk lots means 1000 metre rolls purple Altis pipe and 2m wide (1m folding out to 2m wide) by 50m long rolls of perforated plastic.

Lay manifold length in position. The manifolds are usually pre fitted with take offs.

Manifolds are placed and attached as per instructions in separate section.

A suitable marker e.g. reinforcing bar may be driven into the ground adjacent to the end of the delivery pipe to facilitate location at a later date. An end cap is temporarily placed on delivery pipe end. A Permanent end cap is to be fitted on opposite ends of manifold.

Roll out the perforated plastic sheeting to cover the sand-pad, lap and join sections using PVC ducted tape. Overlap by not less than 50 mm.

Cut a simple cross in the perforated plastic when it is to be pulled over a penetration pipe. Keeps cuts to a minimum.

Lay purple pipe at 450 mm centres. The Altis pipe is run out in lengths no greater than 50 metres. The Altis pipe is secured with duct tape at 1.8 m intervals, ensuring the emitters are facing down and there are no twists in the line.

Attach Altis pipes to the manifold Take-Offs and secure each one with a lock ring, then extend to other end of sand-pad, overlaying the perforated plastic. Lay pipes parallel to each other with Emitters facing downwards. Spacing is 450 mm apart for full underslab.

Open ends of Emitter pipes are closed off by attaching 00010 Universal line end stoppers.

Following installation, inspect ALTIS for incomplete or loose connection and/or damage caused by others on site.

Observe the Builder's laying of polythene waterproof membrane and steel reinforcing prior to concrete pours to ensure the Altis System is not damaged.

If possible it is best to install just before the concretor but if not possible install then return prior to concrete pouring to observe laying of polythene waterproof membrane.

At a suitable time complete injection point(s) and install injection box(es) to suit landscape and/or paving heights.

Measure accurately on plan where injection boxes are to be installed and mark installation Copy of plan to be retained as required by AS3660, together with installation check sheet (completed).

#### PLEASE NOTE:

The P.C.O.s pump output (litres per hour) determines the size of any one system, e.g. a 100 square metre system requires a pump with minimum capacity of 3426 litres per hour. The maximum length of any one Emitter pipe must not exceed 50 metres from any one take-off barb.

Update any durable notices in meter box or according to State regulation. If there is no meter box hand then hand the durable notice to owner or builder. After completion retain a copy of check lists including a record of satisfactory pressure check.

The ALTIS Horizontal Barrier System must be laid on a minimum 50mm of depth or depth as specified by the Termiticide manufacturer, of clean bedding sand/porous material deemed suitable for such use.

### Summary of on Site Work for Full Underslab system using bulk goods.

1. Preliminary work includes viewing plans and inspection of site prior to Altis System Installation, having regard for footing, slab, plumbing, electrical, and any unusual construction details. Decide placement of injection point(s), manifold(s), and layout of Emitter pipes to minimise interference with other building procedures.

Obtain copy of plans and discuss suitable injection points with Builder/Architect/Site Supervisor. Set installation date and time.

Draw plan of the site area being treated detailing injection point(s), position of manifold(s), and direction of pipes and parameters of area being treated. The injection point(s) must be numbered and recorded on job sheet with the area in square metres.

2. Find site injection point from plan.
3. Site-clear all debris. Check site to make sure all plumbing pipes are installed and that sand level is correct. Check site injection points and ensure that emitter pipes do not exceed recommended length.
4. Lay perforated plastic, using duct tape to join sections with 50mm overlap. Cut a simple cross in the perforated plastic when it is to be pulled over a penetration pipe.
5. Install manifold pipes including pump up point. Make sure not to exceed the 50 metre maximum of length each line. Never exceed 180 m<sup>2</sup> from any one pump up point; less if your pump has low capacity.
6. Run emitter pipes over pad - connect to manifold pipe using blue ring joiners. Do not exceed 50 metres per length. Emitters must always face down. Emitter pipes must not be twisted.
7. Duct tape pipes into position at 1.8 m or less intervals.
8. Fit Universal Line End Typhoon & Ring to end of each line.
9. After installing injection point(s) inspect site to ensure job has been installed correctly and no joiners left off.
10. Fit stickers to meter box or cupboards as required by State regulation.

### **DIAGRAMS OF A FULL UNDERSLAB**

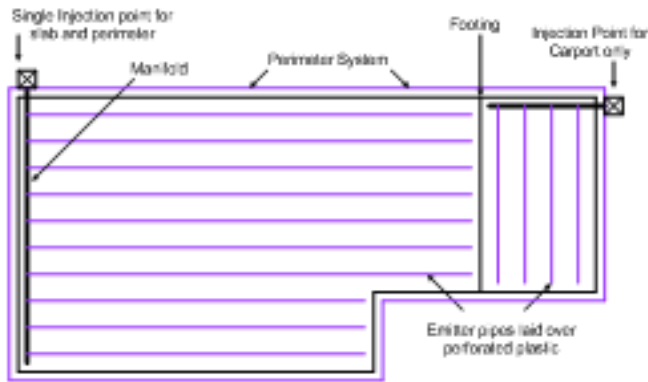

Plans of ALTIS Premium System under concrete-on-ground of new House and Carport - Plan View

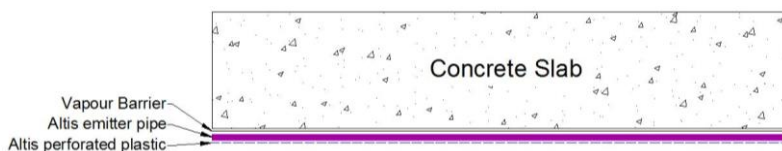
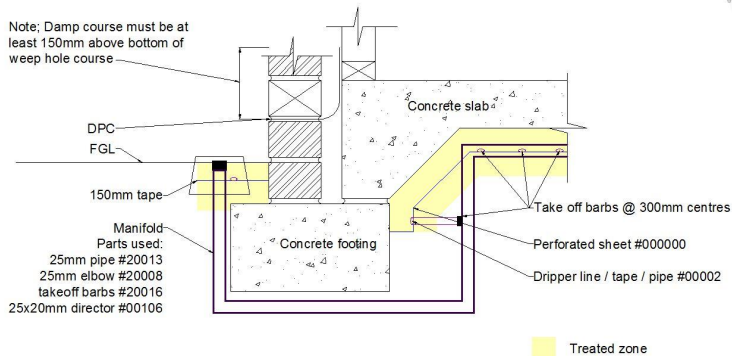
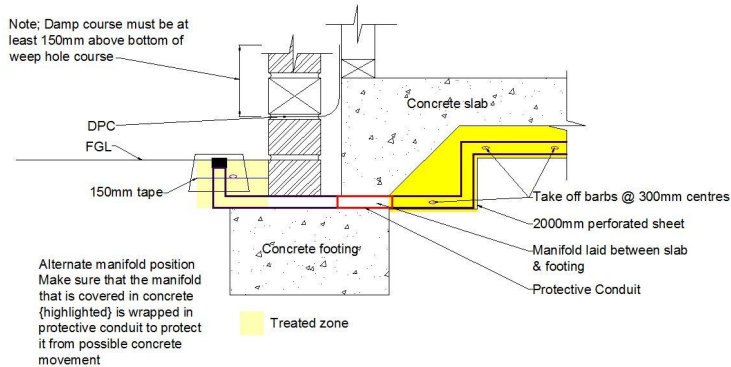

## **INTERNAL PERIMETER / INFILL SLAB Installing using Pre assembled system**

This is in a roll which is 50m in length, 600mm wide and has 2 Altis pipes 300mm apart. It is suitable only for horizontal barrier for flat concrete on ground slabs including Waffle pod design.

The Pre Assembled 600 under slab sheet and Altis pipe product, is simply rolled out in runs up to 50m to cover the complete area on the under slab.

Cut off excess and join corners.

Each run of the Altis emitter pipe is fitted to the 25 mm delivery manifold connected to the 25mm delivery (lead in ) pipe to the outside of the slab area, using take offs from the manifold pipe.

The opposite end of each run of the emitter pipe will be sealed using the Universal line end stop.

This installation **MUST** be completely covered by polythene waterproof membrane before the steel reinforcing prior to concrete pour.

### *Summary of on Site Work for Altis system.*

1. Preliminary work includes viewing plans and inspecting site prior to Altis System Installation, having regard for footing, slab, plumbing, electrical, and any unusual construction details. Decide placement of injection point(s), manifold(s), and layout of pipes to minimise interference with other building procedures.  
  
Obtain copy of plan and discuss suitable injection points with Builder/Architect/Site Supervisor. Set installation date and time.  
  
Draw plan of the site area being treated detailing injection point(s), position of manifold(s), and direction of pipes and parameters of area being treated. The injection point(s) must be numbered and recorded on job sheet with the area in square metres.
2. Find the site injection point from plan.
3. Site clear all debris. Check site to make sure all plumbing pipes are installed and that sand level is correct. Check site injection points and ensure that emitter pipes do not exceed recommended length.
4. Lay perforated plastic, using duct tape to join sections with 50mm overlap. Cut a simple cross in the perforated plastic when it is to be pulled over a penetration pipe.
5. Install manifold pipes including pump up point. Make sure not to exceed maximum length of the system. Never exceed 180 m<sup>2</sup> from any one pump up point; less if your pump has low capacity.
6. Run emitter pipes over pad - connect to manifold pipe using blue ring joiners. Do not exceed 50 metres per length. Emitters must always face down. Emitter pipes must not be twisted.
7. Duct tape emitter pipes into position at 1.8 m or less intervals.
8. Fit Universal Line End Typhoon & Ring and connect to end of each line.



9. After installing injection point(s) inspect site to ensure job has been installed correctly and no joiners left off.
11. Fit stickers to meter box or cupboards as required by State regulation.

### **300MM INTERNAL PERIMETER SYSTEM**

This system is a single line fixed to the centre of a 300mm wide perforated plastic sheet. It is available in 50m rolls. We do not advise using the economy version of the system unless the soil is clear, clean and able to easily absorb chemical. This information is enclosed in our technical opinions.

Suitable to form the horizontal barrier of the internal perimeter of slab and the lead up to service and / or post penetrations for slab on ground construction. Assembly and pumping is the same as a 600mm wide.

## 600 wide

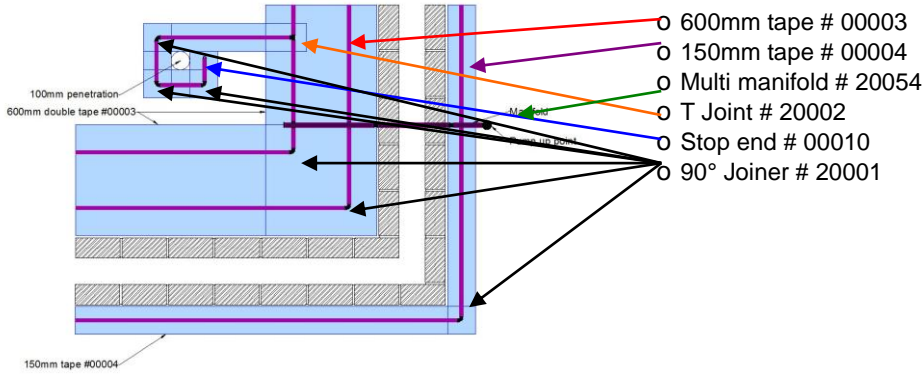

## 300 wide

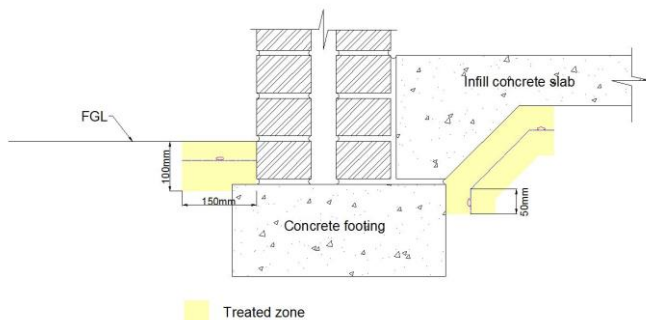
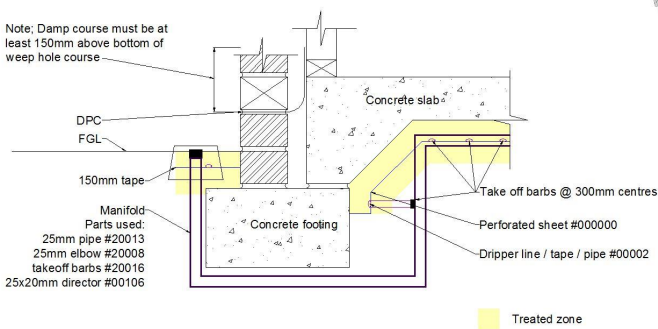
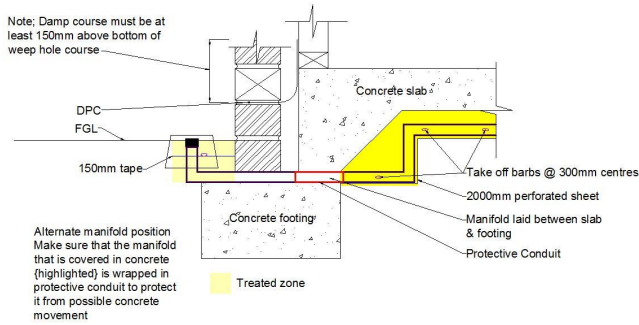
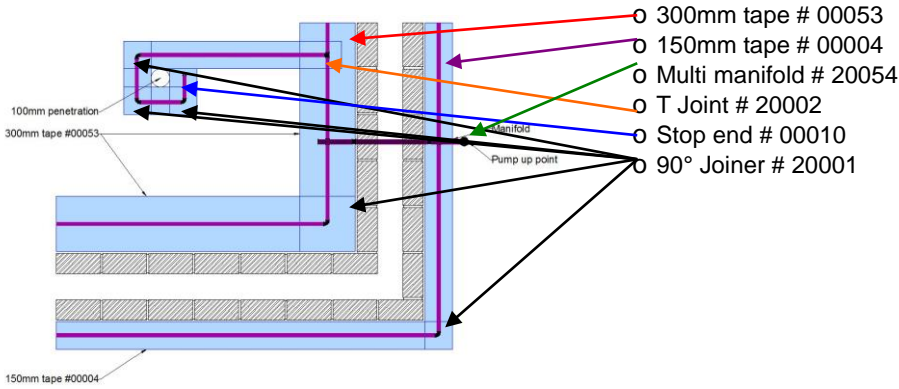

# PENETRATIONS

## Fittings Used;

- 150mm tape #00004
- Tee #20002
- Stop end #00010
- 90 elbow #20001

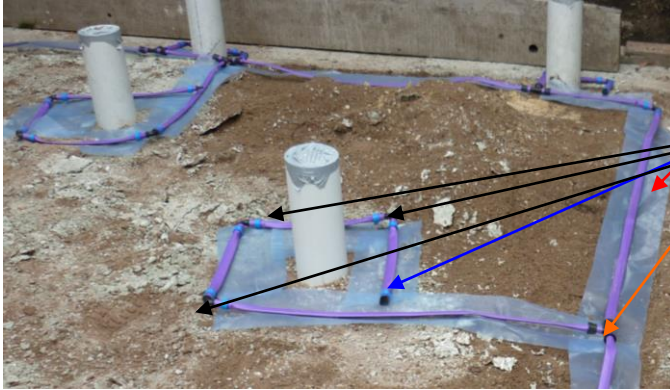
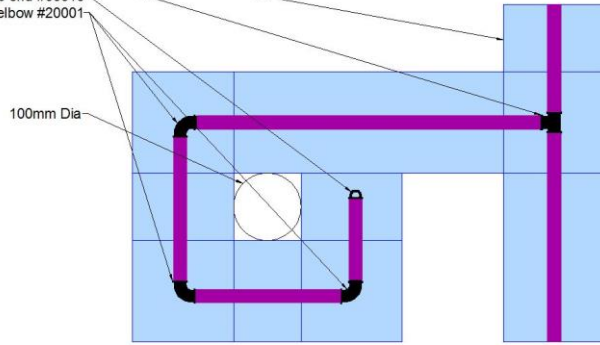

- o 150mm tape # 00004
- o T Joint # 20002
- o Stop end # 00010
- o 90° Joiner # 20001

## DAM WALL EXTERNAL PERIMETER BARRIER SYSTEM

External Perimeter system- 300mm retainer.

The 300mm wide plastic is **not perforated** and the dripper line is fixed to the 300 sheet 75mm in from one edge. The dam wall lines the outside of the trench to the footing with the ribbon on the inner side to create a consistent treated zone.

This is our preferred method. Chemical is forced against the true building base and uses correct volume of chemical.

External perimeter can be pumped 50 m from each take off point or 100 m from a single pump up point with two take off barbs.

Suitable for barriers at a depth 100-300mm, using the 300mm **unperforated sheet** as a dam wall. This is a 300mm wide unperforated sheet, fitted with 1 (one) run of the emitter pipe fixed to the sheet. The run of emitter pipe is 75mm in from the one outer edge. The feeder line can be at the base if the sheet can cover the full trench or on the outer soil wall, being 75mm below the finished soil level. This will form a treatment area 150mm wide and to a depth of 300mm when applied to following examples or an average of 150 wide in the above example.

When digging a trench a large square mouth shovel should give approximately correct trench depth, and this method is best in sand. If working in soil that will not fall back in the trench the alternative method works well using a trenching shovel.

### EXTERNAL PERIMETER SYSTEM - 150mm perforated.

Suitable for barriers at a depth 0 -100mm, using the 150mm wide sheet in the horizontal plane. This is a 150mm wide perforated sheet, fitted with 1 (one) run of the emitter pipe fixed to the sheet. The run of emitter pipe is centred with this run 75mm in from the outer edges. This installation needs to be covered by a plastic sheet when directly under concrete or covered with 25 to 50mm of soil. This will form a treatment area 150mm wide and to a depth of 100mm.

The method is used where the footing is accessible and the total depth of the treated area does not exceed 100mm depth. For all other requirements the minimum method will be our “dam” construction which forces chemical against the true building base and uses the correct volume of chemical or to install 150mm runs in layers 100mm apart horizontally.

#### PLEASE NOTE:

1. Your tank size and pump output (litres per hour) determines the size of any one system, e.g. a 100 lineal metre system requires 1.5 l/meter of 150mm system. The maximum length of any one Emitter pipe must not exceed 50 metres off any one Takeoff Barb
  - 1a. All treated areas/zones are required to have a minimum width of 150mm outside the footing line and a minimum depth past the top of the footing of 50mm and a minimum depth overall of 80mm provided that an area 50mm below the top of the footing is treated.
2. Update any durable notices in meter box or according to State regulation. If no meter box hand to owner or builder.

3. The Altis Barrier System must be laid on a minimum 50mm of clean bedding sand/porous material deemed suitable for such use as advised by the Australian standards and/ or as specified in the product manufactures label.

## **CALCULATIONS**

For all profiles the treatment rates are as per the label a rate of 100 litres per cubic meter of soil.

To calculate this:

width X depth X length = (volume) X 100 L. = volume of mix.

All measurements in metres. E.g.

$0.15 \times 0.1 \times 100\text{m} = 1.5\text{m}^3 \times 100 \text{ L} = 150\text{L}$  or 1.5 L/m

## **EXTERNAL PERIMETER SYSTEM USING 300 MM DAM WALL WHEN BACKFILL IS PRESENT**

Install at a depth of 100-300mm using the 300mm unperforated sheet as a dam wall.

The feeder line can be at the base if the sheet can cover the full trench or at the top being 75 mm below the finished soil level. This will form a treatment area 150mm wide and to a depth of 300mm. The ground level slope is preferred by BCA.

External Perimeter system - 150mm perforated combined with 300mm dam wall system. Standard system barrier at a depth 300-450mm, using the 150mm perforated sheet in the horizontal plane at the top of the footing and the 300mm unperforated as a dam wall, the feeder line will be at the top being 75mm below the finished soil level. This will form a treatment area 150mm wide and to a depth of 450mm. The ground level slope is preferred by BCA.

For all profiles the treatment rates are as per the label a rate of 100 litres per cubic metre of soil.

To calculate this:

width X depth X length = (volume) X 100 L. = volume of mix.

All measurements in metres. E.g.

$0.15 \times 0.1 \times 100\text{m} = 1.5\text{m}^3 \times 100 \text{ L} = 150\text{L}$

PLUS

$0.2 \times 0.3 \times 100\text{m} = 6\text{m}^3 \times 100 \text{ L} = 600\text{L}$

TOTAL

750L

The 150mm perforated sheet and tape can be used without the 300mm retainer only when the 150 is layered each 200mm with one layer not more than 50 mm below the finished soil level.

The maximum length of any one Emitter pipe must not exceed 50 metres off any one Takeoff Barb

## EXTERNAL PERIMETER SYSTEM INSTALLATION

View plans and inspect site prior to Altis Perimeter System installation, making sure that all external plumbing is completed and having regard for footing and slab details. Decide placement of injection point(s) and layout of trench to take Emitter pipe, to minimise interference with other building procedures.

For a standard external perimeter with 300 mm dam wall dig a trench to a depth of 50 mm below top of footing and 150mm outside the edge of the footing with outside sloping at 45 degrees to footing surrounding the building Note minimum total depth of treated area as per product label 80- 100mm. Extend to all piers and posts that connect to the building. Lay 300mm wide polythene in trench with approximately 50mm against the footing and the remainder returning up the 45 degree slope. This is in order to contain the Termiticide mix in the trench.

Provide for an overlap of 25-50mm when joining polythene trench liner, and secure with the 50mm waterproof adhesive tape.

Install delivery pipe(s) with single Take-Off in injection point housing. Ascertain expected finished height of external paving or ground level and install top of injection point housing flush at that level. Attach flat section Emitter pipe to Take-Offs and secure with locking ring. Lay 150mm wide system in the bottom of the trench adjacent to the footing, ensuring that Emitter holes face down.

Close end with end stops.

Fill trench with sand/soil making sure it is free from debris such as rocks, ensuring polythene trench liner and Emitter pipe remain in position and undisturbed.

Draw a plan of the area being treated, detailing injection point(s). Parameters of area(s). The injection point(s) must be numbered and recorded on job sheet.

Copy of plan to be retained on behalf of Altis together with installation check sheet (completed).

For other examples use illustrations for a guide to sand but always provide clean sand backfill.

### PLEASE NOTE:

1. The maximum length of Emitter pipe should not exceed 50 metres off any one Takeoff Barb when using 150 wide sheet & tape with 2.7litres per hour Emitters at 175mm spacing.
2. Update any existing durable notice or install a new durable notice in Householder's meter box, or according to state regulation, if no meter box hand durable notice to owner or builder.
3. A record of satisfactory pressure check to be provided and a copy of certificates and plan of area and injection points with a copy to retained on behalf of Altis.

NOTES: Additional pump up points may be used on wider spans due to pressure of fill material against the installation.

## DIAGRAMS & PHOTOS OF 150 WIDE

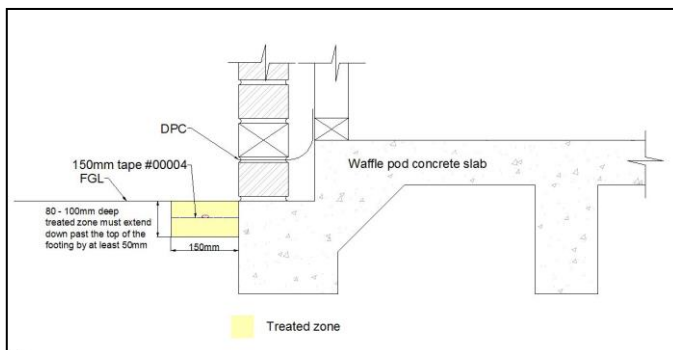
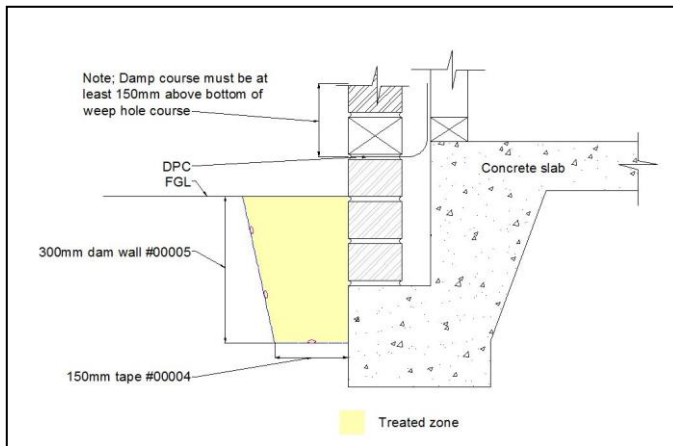
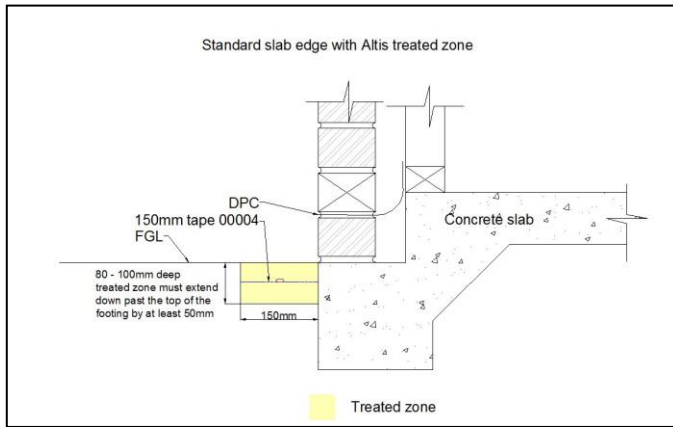

## SPECIALS

## DIAGRAMS & SOLUTIONS

### VERTICAL BARRIER – SYSTEM INSTALLATION

View plans and inspect site prior to Altis system installation, having regard for retaining wall details, plumbing, electrical, and any relevant construction details. Decide placement of injection point(s), manifold and layout of Emitter pipes to minimise interference with other building procedures. Consult with Site Supervisor on position of injection point(s).

Lay polythene membrane to cover wall surface for treatment. Attach in position with fast drying glue. Provide an overlap of 50mm when joining polythene sheeting, and secure with continuous 50mm waterproof adhesive tape.

**NOTE:** The maximum length of any Emitter pipe is to be 50 lineal metres off any one Takeoff Barb

Cut to size and join manifold pipes, ensuring take-Off holes are in line. Connect manifold pipe via delivery pipe to injection point, with screw cap in place. Open end(s) of manifold pipe to be capped. Prior to on site installation, Manifold pipe segments should be prepared with holes drilled at 200mm centres, rubber grommets and Take-Offs in place.

Attach Emitter pipe(s) to Take-Offs and secure with plastic clips. When attaching Emitter pipe to Take-Off, ensure sufficient pipe, emitter free for fitting and fixing. Run out Emitter pipe(s) to extent of wall area to be treated, ensuring Emitter holes face towards wall. Pipes can be placed horizontally as drawing or vertically.

Seal open ends of Emitter pipes by inserting stop ends.

Fix manifold pipe to polythene sheeting (previously attached to wall) with fast drying glue such as liquid nails. Arrange Emitter pipes in horizontal parallel lines and fix with fast drying glue such as liquid nails at 1.0 metre centres to the polythene sheeting and / or saddle clamps as surfaces may not always suit glue. Cover with plastic builder's membrane unperforated securing with nail gun.

Draw on plan, wall location and area being treated, detailing injection point(s), position of manifold(s), director of Emitter pipe(s) and perimeter of area(s).

The injection point(s) must be numbered and recorded on job sheet with the area(s) in square metres.

Following installation, inspect Altis for incomplete or loose connections and/or damage caused by others. Observe back filling of wall area to ensure Altis is not damaged, using only clean rubble free bedding sand. Draw a plan of the area etc.

#### PLEASE NOTE:

The P.C.O.'s pump output (litres per hour) determines the size of any one system, e.g. 100 square metre systems can take a total capacity of 3426 litres per hour, whereas we are only required to pump 5 L/m<sup>2</sup> ie 500 Litres. You will need to check your pump prior to carrying out any work.

This can be simply carried out by pumping into a say 5 Litre jug and timing it. Extrapolate the time ie 30 seconds to pump 5 Litres multiply to pump 500 Litres = 3000 seconds which = 50 minutes. Note the length of hose you have on your truck and whether or not there is a height difference between your truck and the area to be pumped are also issues you need to take into account.

Update any existing durable notice or install a new durable notice in Householder's meter box, if no meter box, hand to owner or builder. Send copy of any certificates.

**WS00A2**

**WS00A1**



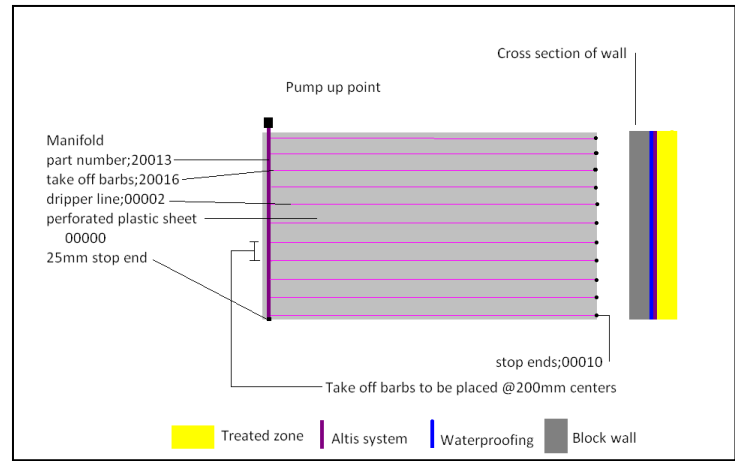
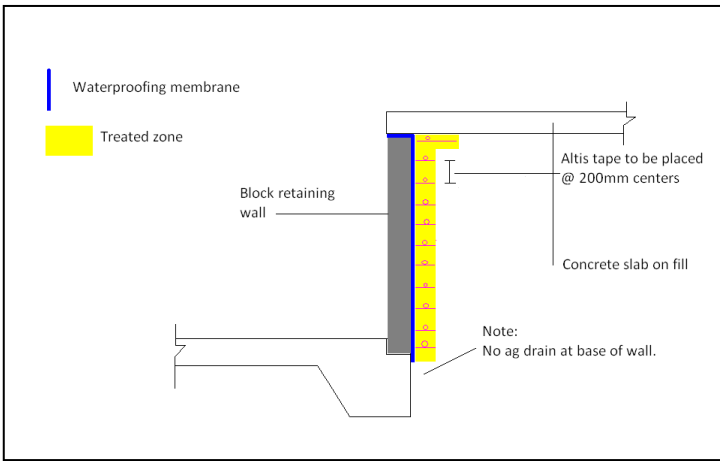

**EPDREDBM**

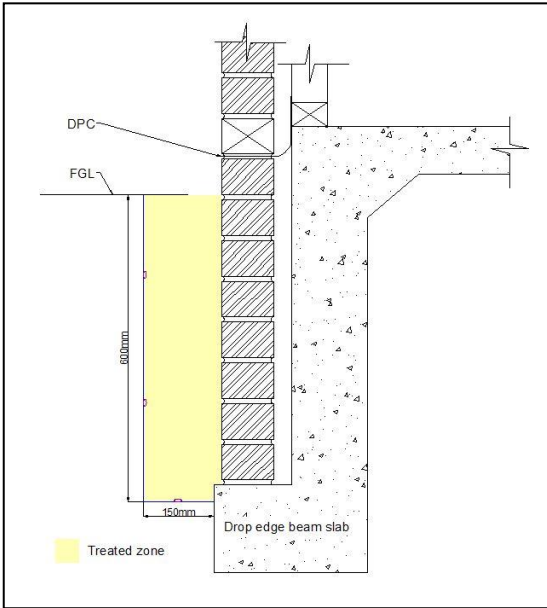

**TRCA00A1**

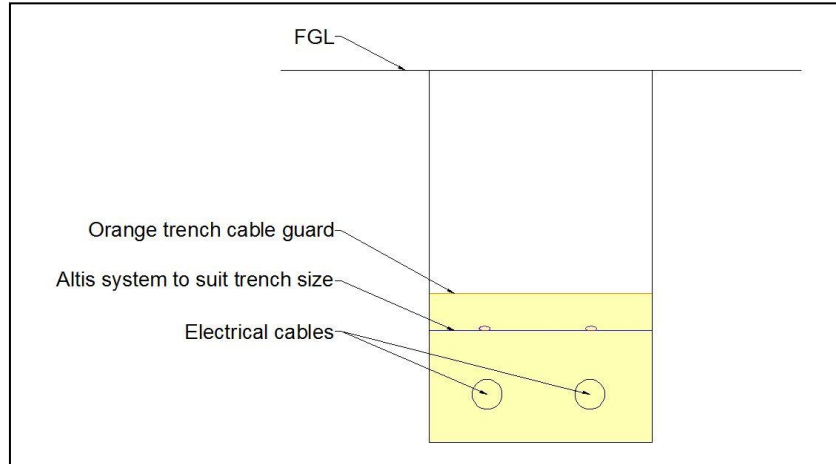

**EXT000A1**

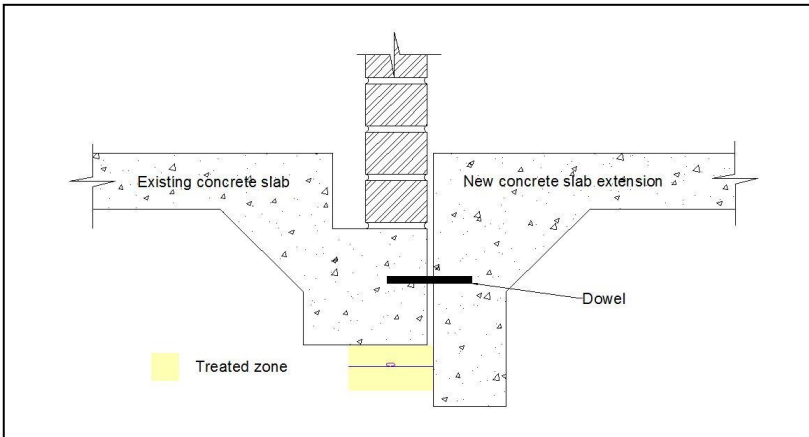

**RW1**

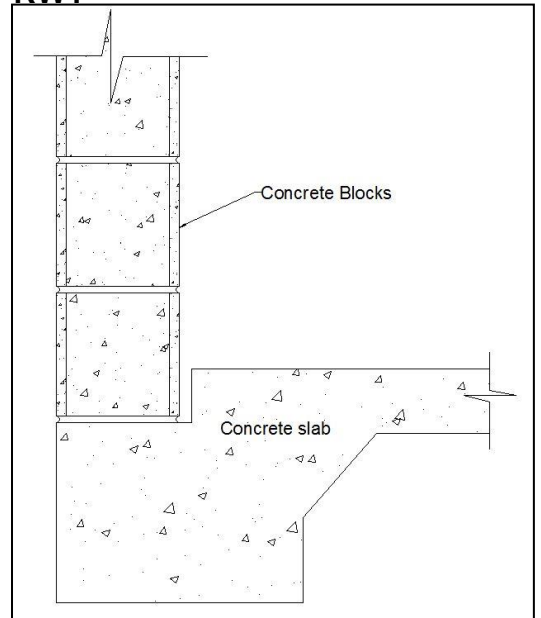

**INFBEA**

**INFEP600**

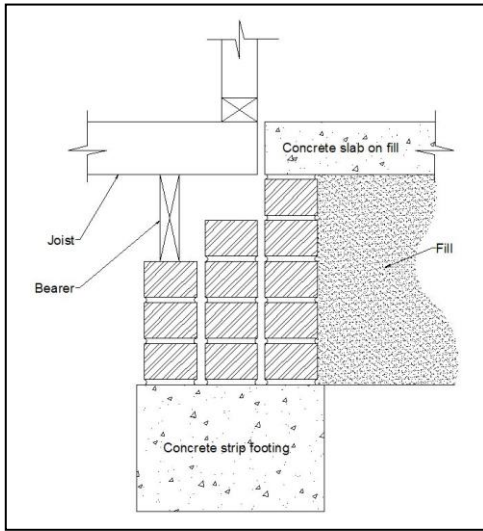

**BEJOSF00B2**

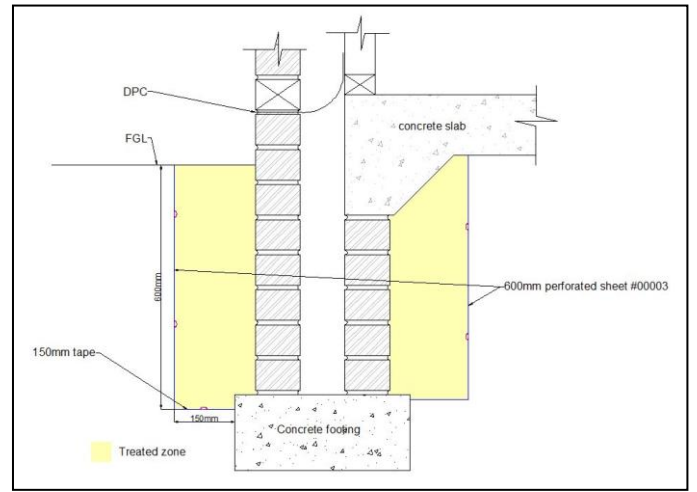

**BEJOSF00A1**

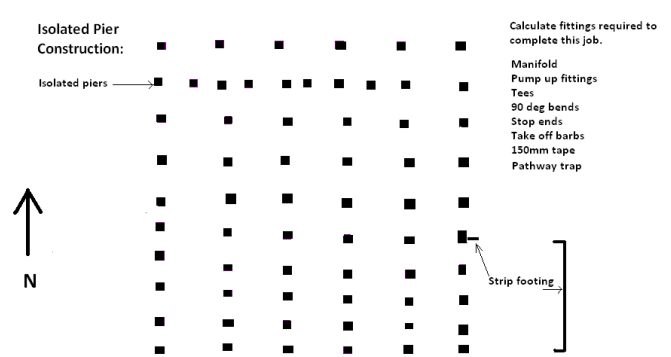
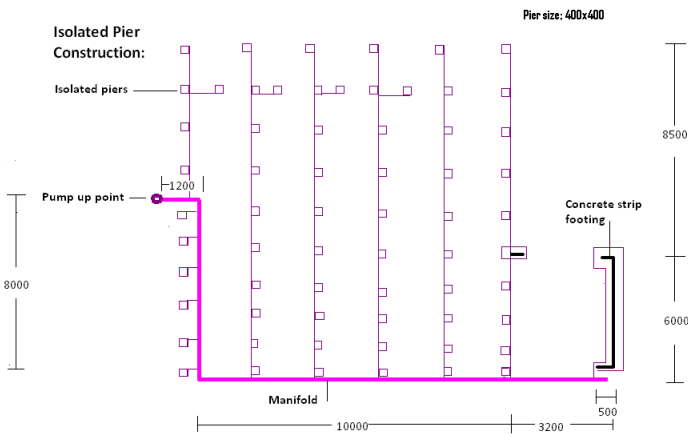
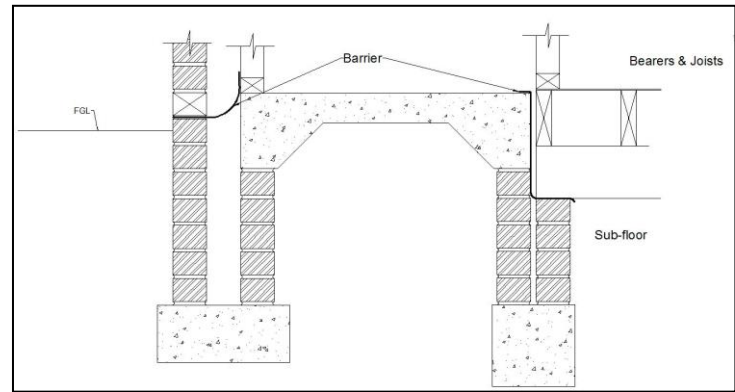
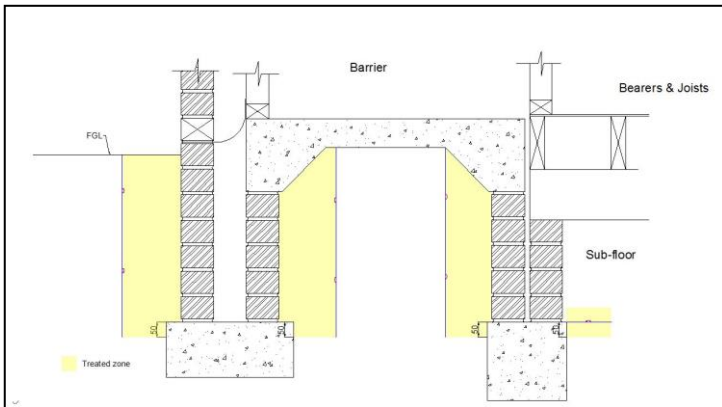

### CJ000A1

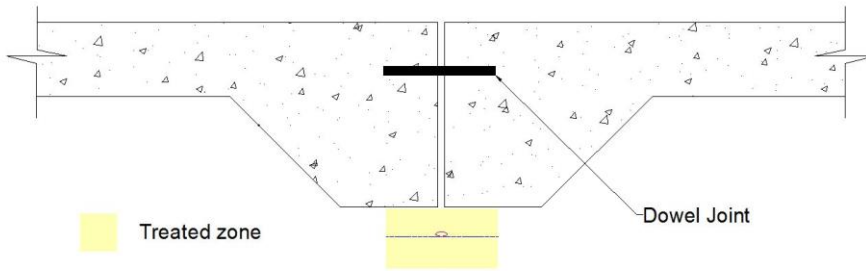

### CJ000A2

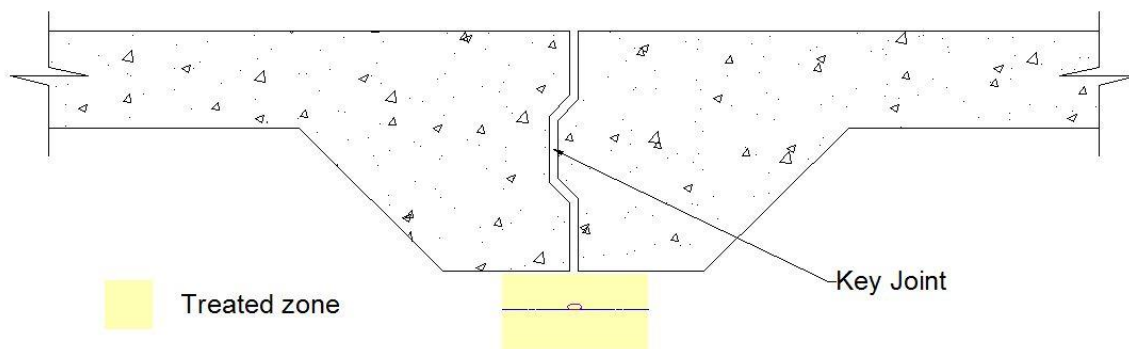

### CJ000A3

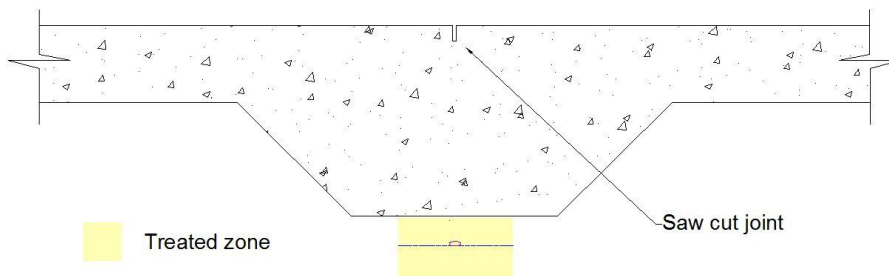

## INSTALLATION OF CABLE TRENCH BARRIER SYSTEM

In addition to normal items from parts list provide plastic sheeting to cover trench. (May be supplied by customer.)

Consult with site supervisor to view plans of site and agree on injection point(s).

**NOTE:** The cable trench(s) have usually been pre-dug, with 100mm of sand in the bottom, cables are laid, and then 100mm sand placed in trench. The Altis system is installed on top of this.

It is advisable that the plastic has the Emitter pipe attached before arrival on site (subject to size and length of trench). The delivery pipe with end cap should extrude from top of the trench approximately half a metre being held with a star picket until finished height of ground is maintained. Cut pipe(s) and inject system. Then install injection box.

When trench has been backfilled and compacted, injection boxes are to be placed, delivery pipes cut to size, and screw caps attached. Copy of trench plan and completed checklist to be retained.

### **USE OF FOAM IN ALTIS SYSTEMS**

The use of a foaming agent in the Altis range of systems can help to achieve the correct label rate of application in areas where Subsidence is known or suspected.

This information previously provided in Tech Note 19: Use of foam in Altis systems.

#### **WHEN CALCULATING THE APPLICATION RATES:**

Apply the following advised methodology:

Calculate the required volume:

1. Using the formula 100 L per m<sup>3</sup> of soil.  
(50m x 0.15x 0.10 x100L = 75 L)
2. Apply 70 % of the volume as normal mix ( 52.5L )
3. To the balance (22.5L) add the foaming agent as per the Manufacture's recommended rate for WET foam. ( expansion ratio 5:1)
4. Apply the foaming mix with compressed air through the foaming RCPU.

The end result will be the correct GRAMS per CUBIC METRE OF SOIL as per the Termiticide label.

**Concrete Sub-Slab Foaming** Rate: 30 - 80 ml Termitafoam® to 5 litre water/ pesticide solution. "Wet" foam is desired for sub-slab applications to adequately saturate the soil.

The foam consistency depends on the amount of foaming agent you add and more importantly the volume of air. It is all trial and error depending on the job. So it is best to start off at low volumes for both the foaming agent and the air. Test foam into a mixing jug until you get a stiff wet foam that will expand around 5 times its volume. This is easy to check:

1. Inject the mix **WITHOUT** air into the jug for 5 seconds, record the volume recovered.
2. Repeat the injection for 5 seconds **WITH** the air and record the volume recovered.
3. Divide volume 2 by volume 1 The answer should be around 5

Use good quality clean water to dilute the concentrate, avoid using hard water. On hot days increase the rate of concentrate up to double strength.

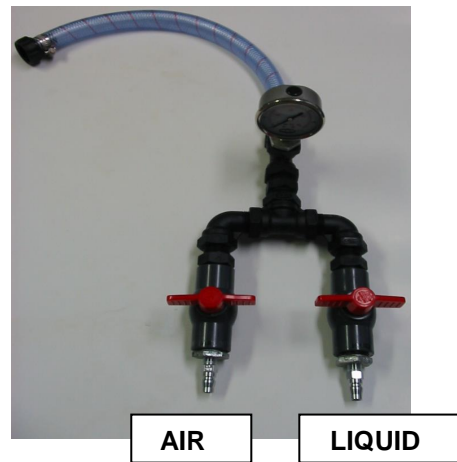
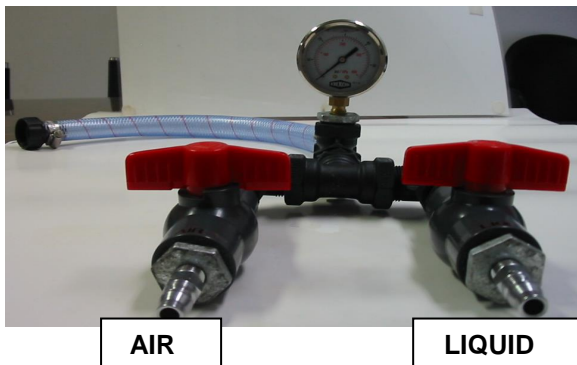

### **RATES TAKEN FROM THE PREMISE and TERMIDOR LABEL AS BELOW**

Foam carriers may be useful in ensuring that a more even distribution is achieved. However it is important that the foam application be calibrated to ensure that the rate of Premise formulation does not fall below 12.5 mL of Premise 200 SC / m<sup>2</sup> and the rate of Termidor formulation does not fall below 30mL of Termidor / m<sup>2</sup>.

**Mixing table to prepare foam to treat 1 m<sup>2</sup>**

Premise 200 SC (mL)*	Litres of water	Foam expansion ratio	Volume of finished foam/m <sup>2</sup>	Foam consistency
12.5	5	1:1 (i.e. not foamed)	5 L	standard solution
12.5	2.5	5:1	12.5 L	wet foam
12.5	5	5:1	25 L	↑
12.5	2.5	10:1	25 L	↓
12.5	5	10:1	50 L	↓
12.5	2.5	20:1	50 L	↓
12.5	5	20:1	100 L	very dry foam

\*Add the manufacturer's recommended quantity of foam agent to the Premise solution

TERMIDOR Mix Rate	Litres of prepared TERMIDOR spray	Foam Expansion Ratio	Volume of finished foam required / m <sup>2</sup>
600mL/ 100litres of water plus	5	5:1	25 L
	10 (under concrete)	5:1	50 L
recommended quantity of	5	10:1	50 L
	10 (under concrete)	10:1	100 L
foaming agent	5	25:1	125 L
	10 (under concrete)	25:1	250 L



## **INJECTION OF ALL ALTIS SYSTEMS**

## INJECTION OF ALL ALTIS SYSTEMS

### Tools Required:

- The manual
- Vehicle with an approved termiticide tank
- Pump with output minimum of 3426 litres per hour (this will inject a system up to 100 square metres)
- 50 metres 25mm ID flexible hose and connections
- Clean water supply
- Adjustable spanner
- Job and check list sheets
- Site plan with injection points shown
- Remote control pressure unit (R.C.P.U.)
- Termiticide
- Remote Control Pressure Unit (R.C.P.U.) consists of an injection snorkel, a pressure gauge, a liquid flow rate meter and one on/off valve. Use the spreadsheet provided for calculations of Termiticide and time to pump up system.

Chemical which is an Altis approved termiticide is to be applied to the system immediately prior to, or following completion of construction. The chemical concentration must comply with the Australian Standard Code AS 3660, relevant Local Government Authority By-Laws and the requirements on the chemical container label.

Check section of building/wall to be treated for any disruption or disturbance of Altis. Inspect condition of injection point and numbering to comply with job sheet. In accordance with job sheet, mix chemical to required specification, run pump motor to thoroughly agitate chemical as per the product label. Remove screw cap, attach remote control pressure unit (R.C.P.U.) to injection point, and zero flow rate meter - Pump Altis approved termiticide through R.C.P.U. into Altis maintaining a constant 35 to 140 Kpa optimum 100 Kpa but do not exceed 140 Kpa. Monitor pressure and volume on pressure gauge and flow rate meter respectively.

When injection has been completed, inject clean water one tenth of the volume of chemical used. This water will force all residue out of the system, flushing clean the internal surfaces of Altis, thereby helping to maintain the system in good working order. On completion of injection, replace screw cap and secure injection box lid if applicable - chemical injection must be carried out by a Licensed Pest Control Technician. Provide copies of Certificate as per the Australian Standards Code, to the builder or owner.

**In situations of highly reactive clays** the following procedure is to be followed to determine the quantity of water required to flush a system. Find the volume of the 25mm manifold pipe plus the 25mm delivery pipe. Manifold pipe 7 m, Delivery pipe 2 m

$(25/2) \times (25/2) \times \text{Pi} \times (7+2)$  divided by 1000 = 4.417 litres add 20% for a safety margin. Inject this amount of clean water into the system.

This calculation is performed on our supplied spreadsheet.

**PLEASE NOTE:** Vertical system emits at 115 litres per hour per square metre at 10 metres head. Update any existing durable notice or install a new durable notice in Householder's meter box, if no meter box, hand to owner or builder. Record of



satisfactory pressure check will be supplied and signed by the operator. Retain a copy on behalf of Altis completed and signed checklist(s).

*Quick summary of pumping of system*

1. Locate injection point(s) on plan and fix injection point(s) into position.
2. Work out from plan how much chemical is to be injected and check soil density.
3. Fill tank to required level and mix with chemical
4. Run pump motor for 15 to 20 minutes to mix chemical correctly
5. Pull out hose and join to RCPU unit.
6. Open tap on RCPU unit to allow small amount of chemical mix to flow through.
7. Go to truck and engage pump.
8. Go back to injection point and open up taps, watching pressure gauge at all times.
9. When pressure gauge reaches required pressure walk around site, especially in the wet areas to ensure that a plumber has not cut pipes and that chemical is not coming up around pipes.
10. When full flow rate meter indicates correct amount, turn off pump.
11. Disconnect chemical hose
12. Flush system with an amount of water equal to 10% of the chemical mix pumped through the system.
13. Disconnect RCPU and screw on black filler cap.
14. Install safety box lid.
15. Place durable notices in meter box.



### **THE REMOTE CONTROL PRESSURE UNIT (RCPU)**

An RCPU unit is used for injecting with chemical and water mixed as emulsion or water for flushing. It also acts as a non-return valve.

It comprises of two gauges, which are a flow rate meter and a pressure gauge, connectors at each end, one for connection to the pump output and the other to the Altis system. There is also a ball valve tap which is used to adjust the system pressure which must be held at lower than 140 Kpa (100 Kpa optimum).

A flow rate meter measures quantity in litres. The pressure gauge is measured in Kpa as well as lbs/square inch and is used to control pressure in the system.

The RCPU is attached to the valve socket on the Altis injection point and the other end to the hose from the pump.

The procedure is to connect the RCPU unit to injection point and connect the pre treat hose to the RCPU unit, ensuring the ball valve tap is turned off. Start the pump and mix chemical emulsion for 15-20 minutes.

Return to RCPU unit, slowly turn the ball valve tap on, all the time watching the pressure gauge. Once the gauge has reached 100 to 140 Kpa, let the pump run until the required amount of solution has filled the system as per installation sheet requirements.

Flush the system with clean water.

Never pump higher than 140 Kpa, 100 Kpa is recommended.

**Refer to page 40 for illustrations of RCPU in the parts list. Part # 20037**





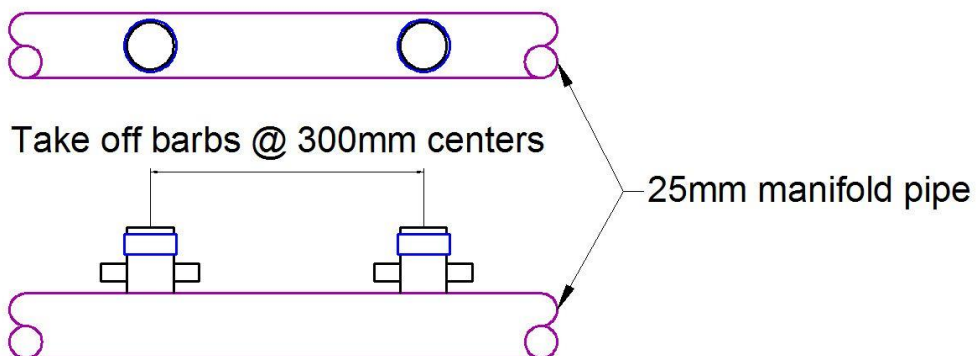
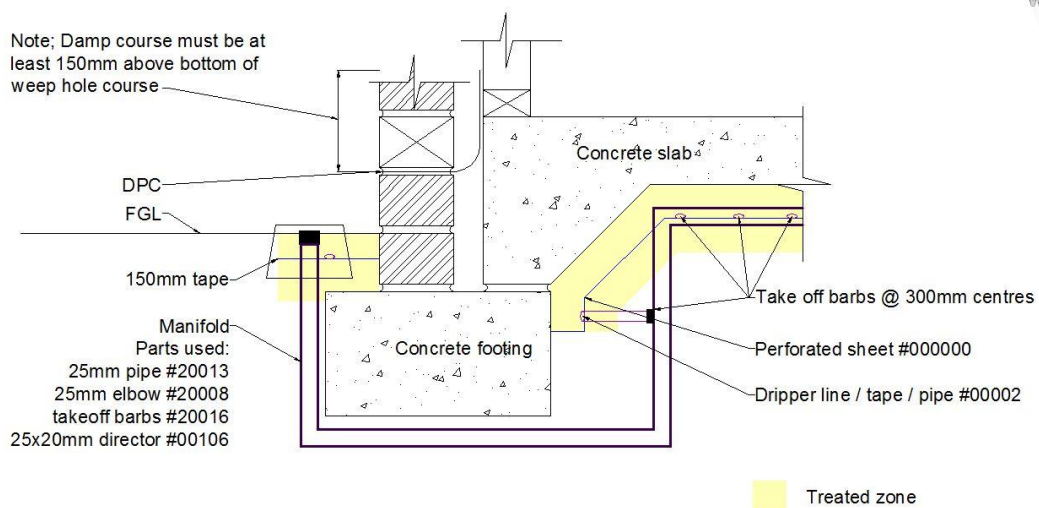
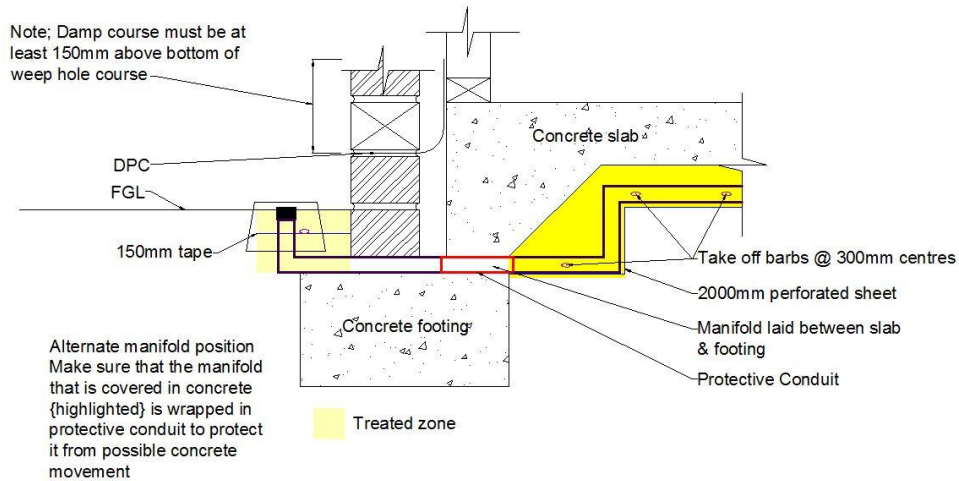





## INJECTION POINT METHODS





**PARTS LIST AND DESCRIPTION OF HOW THEY ARE USED**

PARTS DESCRIPTION	PARTS PHOTOS	CODE
<b>INTERNAL PERIMETER PRE-MADE</b>		
<b>600mm x 50m Roll</b> This is a 600mm wide perforated plastic sheet, fitted with 2 (two) runs of the dripper line fixed to the sheet. Each run of dripper line is spaced at 450mm apart with each run 150mm in from the outer edge. The roll is 50m in length. Suitable to form the horizontal barrier of the internal perimeter of slab and cover service penetrations for slab on ground construction. Roller sold separately.		00003
<b>300mm Perforated x 50m Roll</b> Suitable to form the horizontal barrier of the internal perimeter of slab and cover service penetrations for slab on ground construction. This is a 300mm wide perforated plastic sheet, fitted with 1 (one) run of the dripper line fixed to the sheet. The dripper line is in centred with this run 150mm in from the outer edge and is in a roll 50m in length. Roller sold separately.		00053
<b>2m Wide Perforated Plastic Sheet</b> If you use this product, you will need to purchase a 1,000-metre roll of dripper line (Code: 00002) and make a system as described in the manual onsite. You will also need a special purpose-built manifold with multiple take offs and it is highly recommended that you contact Altis whenever you encounter one of these jobs. Suitable for use in full under slab installations.		00000
<b>EXTERNAL PERIMETER PRE-MADE</b>		
<b>150mm x 50m Roll</b> A 150mm wide perforated sheet, fitted with 1 (one) run of the dripper line fixed to the sheet. The run of dripper line is centred 75mm in from the outer edges and is in a roll 50m in length. Suitable for barriers at a depth 0 -100mm, using the 150mm perforated in the horizontal plane. Roller sold separately.		00004
<b>300mm Unperforated x 50m Roll – Dam Wall</b> A 300mm wide unperforated sheet, fitted with 1 (one) run of the dripper line fixed to the sheet. The run of dripper line is 75mm in from one outer edge. The dripper line can be at the base if the sheet can cover the full trench or on the outer soil wall, being 75mm below the finished soil level. This will form a treatment area 150mm wide and to a depth of 300mm. Available in 50m in lengths. Suitable for barriers at a depth 100-300mm, using the 300mm unperforated as a dam wall. Roller sold separately.		00005
<b>DRIPPER LINE FITTINGS</b>		
<b>Inline joint</b> Suitable fitting to join two pieces of dripper line together. No clips required as the blue slip lock joints provide the necessary seal. Sold in bags of 25.		00009
<b>Stop end</b> Suitable fitting to put on the dripper line at the end of a run. No clips required as the blue slip lock joints provide the necessary seal. Sold in bags of 25.		00010
<b>90° joint</b> Suitable fitting to put on the dripper line to go around 90° corners. No clips required as the green slip lock joints provide the necessary seal. Sold in bags of 25.		20001
<b>T joint</b> Suitable fitting to link the dripper line into penetrations also can be used to go around external pipes and penetrations. No clips required as the green slip lock joints provide the necessary seal. Sold in bags of 25.		20002
<b>45°/135° joint</b> Suitable fitting to put on the dripper line to go around bay windows. No clips required as the green slip lock joints provide the necessary seal. Sold in bags of 25.		20035
<b>PURPLE MANIFOLDS</b>		
<b>Multi Manifold single/double</b> Suitable to link the system to a pump up point. For an external perimeter installation for up to 100Lm used for 150mm external perimeter and 300mm unperforated (dam wall) and also for 300mm economy under slab. Pre-assembled single/ double Manifold kit complete with 4 X 25mm herbie clips and a Pump-up tag all in a bag. Sold individually.		20054
<b>Purple Manifold complete double 600mm take off</b> Suitable to link the system to a pump up point. For an internal perimeter installation up to 100Lm. Pre-assembled double Manifold kit complete with 4 X 25mm herbie clips all in a bag.		20053
<b>PUMP UP FITTINGS</b>		
<b>Square pathway trap</b> This is to allow the manifold pump up point to be concealed. This is lockable and is the recommended pathway trap. It comes with 2 screws and requires an Allen key to tighten.		00031
<b>Pump up tags</b> This tag can be attached to the manifold to indicate the length of dripper line runs that have been installed. It enables you to ensure that the system is not under or over serviced when charging with termiticide.		20023
<b>OTHER ITEMS</b>		
<b>Wall plates</b> As part of the CSIRO opinion for systems installed in QLD where a concrete mowing strip is prescribed. Use of the wall plates allows the system to be installed without a mowing strip. These must be placed on each face of the perimeter of the building no more than 6 metres apart.		00038
<b>RCPU w/ Pressure gauge and 1 tap</b> This tool is used for pumping up the Altis Reticulation System. It is connected to the pump-up fitting in the pathway trap. The tap enables you to control the pressure. It is recommended that you use a flow Meter in conjunction with this fitting.		20037

**Plastic Roller**

*The roller will prevent the pre-made perimeter rolls from collapsing and twisting into knots. it will also make the job easier to install*

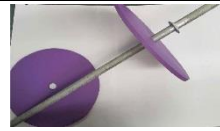

00060

**NOTE: Black Link Up Line is no longer available**



## **CONSTRUCTION PRELIMINARIES**



### **Materials required:**

(All materials as listed must be Altis approved and purchased from Altis distributors.)

- Materials from Parts list
- Pesticides WARNING Durable Notice
- Injection box. (Childproof trap)
- Termiticide
- Site plan
- Duct tape waterproof
- Installation check sheet and record of satisfactory pressure reached.
- Termiticide
- Liquid nails, saddle clamps or similar for vertical systems

### **Tools Required:**

- The manual
- RCPU
- Pipe cutters
- Scissors
- Stanley Knife
- Shovel standard and trenching
- Small Heavy Hammer
- Soft Broom
- Cold Chisel
- Pliers
- Tape measure/ measuring wheel

### **PRIOR TO SITE**

View plans and inspect site prior to Altis System Installation, having regard for footing, slab, plumbing, electrical, and any unusual construction details. Decide placement of injection point(s), manifold(s), and layout of Emitter pipes to minimise interference with other building procedures.

Obtain copy of plan and discuss suitable injection points with Builder/Architect/Site Supervisor. Set installation date and time.

Draw plan of the site area being treated detailing injection point(s), position of manifold(s), and direction of Emitter pipes and parameters of area being treated. The injection point(s) must be numbered and recorded on job sheet with the area in square metres.

### **CALCULATING PUMP SIZE**

One metre of emitter pipe divided by the spacing of the emitters down the pipe i.e.

0.175m equals 5.714 which is the amount of emitters per lineal metre

One metre of manifold pipe divided by the spacing of the emitter pipes, 0.45 equals 2.222 which is the number of emitter pipes per metre of manifold pipe.

Multiply 5.714 times 2.222 which equal 12.69 which is the number of emitters per sq metre.

Multiply 12.69 by 2.7 equals 34.263 which are the litres per sq metre per hour.

Example 100 m<sup>2</sup> by 34.263 equals 3426 which is the amount. **Refer back to page 25 for calculations.** Calculations also performed in supplied spreadsheet.



## **ADDENDUM**

## **ADDENDUM WHERE SIMILAR CONDITIONS EXIST TO NORTHERN TERRITORY – CLAY.**

### **MANIFOLDS**

Manifolds should be recessed into the sand pad to avoid intruding into the thickness of the slab and cause any structural weakness.

Emitter pipes and polythene are to extend to the edge of the slab and at least half way down the trench. In the case of infill slab the system must be new to the formwork.

### **PERIMETERS**

In conditions where exposed slab edge is forming a physical barrier, we do still see the need for an external perimeter system.

However perimeter systems where an entry point is at or below ground level the following applies.

Under mowing strips, pavers or concrete paths the builder is to provide 50mm of bedding sand. An Altis 150mm wide perimeter system is laid as close to the slab footing edge as possible.

A builder supplied polythene membrane is placed over the pipe and under the mowing strip.

### **THICKENING BEAM**

Where the depth of a beam is more than 300mm the dripper line passes under but is cut and joined with 90-degree elbows. Less than 300mm deep no cutting is required but the trench shoulders should be rounded to avoid an extremely sharp bend on the corner of the Emitter line.

The pipe is then laid into the trench and fixed into position at the top and bottom of the trench. When pumping observe pressure gauge and bring up to required pressure as stated in the manual.

### **PUMP UPS**

The pump up should be carried out after 28 days and not more than 60 days after the concrete has been poured.

## **ADDENDUM: WHERE CLAY AND SIMILAR CONDITIONS EXIST TO SOUTH AUSTRALIA. REFER TO KOUKOUROU ENGINEERS REPORT**

### **RECOMMENDATIONS:**

Pressure can be dropped and should be pumped to achieve minimum water content on high density clay pads.

System should be tested by pumping water equal to 10% of the volume of chemical required. Leaks should be corrected. This is done before concrete pouring.

Chemical pumping should not occur before 28 days or no later than 60 days after the concrete has been poured.

Also note Department of Transport, Urban Planning and The Arts letter re position of PVC pipes under concrete slabs in reactive soils. Quote: PVC piping passing through concrete footing beams in reactive soils to be provided with some protection from fracturing due to differential movement between the soil and the concrete. This can be done by sleeving the pipe within a larger diameter pipe or by wrapping the pipe work in 45mm closed cell polyethylene foam lagging. Note PVC piping to be passed through footing beams in reactive soils, min PVC pipe 30 mm internal diameter. Class 12 PVC pipe is required.



## TECH NOTE

**RE-ISSUE:** 1.2  
**DATE:** MARCH 05  
**REF:** PUMP UP PRESSURE  
**DATE:** MAY 09

When pumping up the Altis Reticulation System your injection pressure must be between 35 kPa & 140 kPa. 100 kPa is recommended

If your injection pressure is any higher then you will blow the emitters and stretch the ribbon tape or pipe. Remember Altis is not a high pressure system, it does not rely on pressure to inject the system like other reticulation products.

When testing the system or flushing the system with water using a hose tap - town water, you must ensure that you only turn the tap on lightly.

DO NOT open the tap fully

Town water pressure is normally above 300-400 kPa. Use a pressure gauge at the injection point. Refer to page 12 of your Installers Manual.

Please instruct all of your staff regarding this issue. If you blow the emitters you will need to replace and reinstall the product, which costs time & money, keep in mind you cannot replace the system once concrete has been poured.

### CONVERTING psi = kPa

psi – kPa multiply psi by **6.8947573**

kPa – psi multiply kPa by **0.14503774**

The Altis Pump Up Tag has been amended to ensure information regarding pump up litreage is not provided to a non accredited installer.

The Pump Up Tag is to be completed by you and placed over the cap of the pump up point/ manifold in the pump up box/ pathway trap.

When there is more than one pump up point in a pump up box, it is advised that you use a different coloured paint type marker to indicate which line the colour refers to. The paint marker should be sprayed on both the cap and manifold extension. This information should also be reflected in your paperwork.

The pump up tags now come with each manifold purchase and will remain available for individual sale as well.

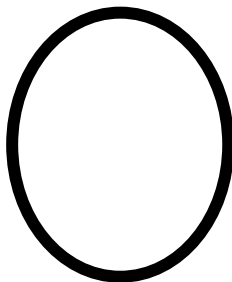
<p><b>Altis Pty Ltd</b> Charged with _____ Charge Date _____ Charged by _____</p>  <p><b>Advanced Anti-Termite System</b></p>
<p>Only to be recharged by an Altis accredited installer. This is a low pressure system and pressures higher than 140kPa may damage the system.</p> <p>Refer to treatment certificate for details of this installation for amount of chemical to be used and/ or if more than one pump up point in this pump up box.</p>

[www.altis.net.au](http://www.altis.net.au)

## 150mm double manifold



## 150mm single manifold



### 300mm double manifold



### 300mm single manifold





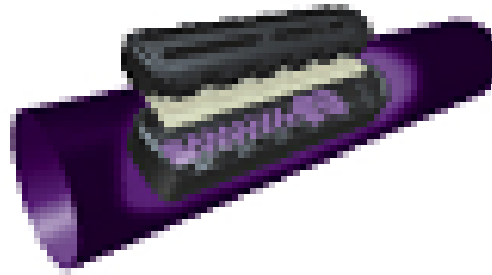

- The emitter is placed every 175mm along the purple pipe.
- The circle at the end is the only place the chemical comes out of.
- The swirls are what keeps the chemical pumping evenly and does not allow any extra chemical out than it should.



This picture is to explain how the chemical is distributed through the use of emitters.

Emitters are on the bottom side of the dripper line facing the perforated plastic. The dripper line is glued to the perforated plastic in the intervals where there are no emitters.

Chemical is distributed out of the emitter holes and spreads over the plastic which is perforated. The chemical seeps through the holes and into the soil areas.

The use of advisory signs, in lieu of the mowing strip, will be at least as effective, or even more so, as a means of notification to the householder that a termite management system is in place around the external perimeter of the structure. The Technical Assessment 222 has a clause requiring “The external system is protected either by paving or advisory signs fixed in close proximity to the barrier to prevent breaching and/ or contamination of the chemical barrier”.

The wall plates cannot be removed without damage to the surface on which they are attached and are readily replaced by the Altis inspectors during an inspection. The wall plates are placed on each facing wall and would be seen when any person is working within the vicinity of the external perimeter. They must not be anymore than 4-6 meters apart. When placing them on the wall they are to be 30-70mm above the finished ground level.

This Technical note is a reissue of Tech Note 5.1 and supersedes the previous Technical Note.

This should be read in conjunction with the Altis Manual and added as an attachment for reference. Please also refer to CSIRO Appraisal Letter “CSIRO Technical Assessment 222- Altis Partial Anti- Termite Irrigation System’ for additional information.

Wall plates can be installed in lieu of a mowing strip. These are available for purchase from Distributors.

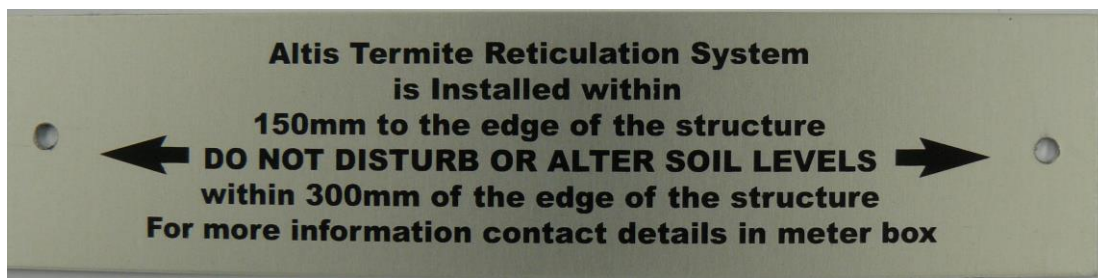

**BAY WINDOW:**

Bay window fittings are now moulded and no clips required.

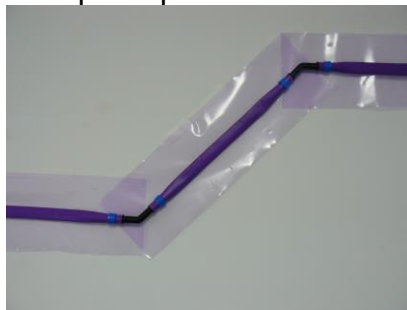
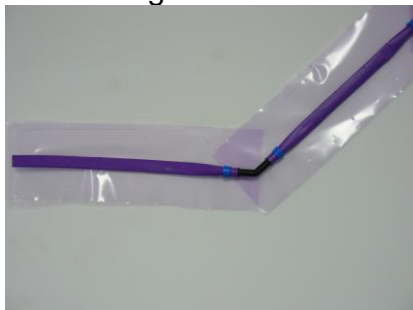
**INTERNAL PERIMETER:**
**600mm Sheet & Tape**

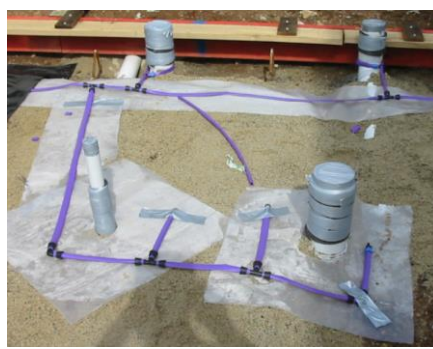
**300mm Sheet & Tape**

**FULL UNDERSLAB:**

## EXTERNAL PERIMETER:

### 150mm Sheet & Tape



## DAM WALL:

### 300mm Unperforated



Instructions on how to fit a flowmeter to your existing standard pump up fitting.

**Step 1 Get your standard pump up fitting**



**Step 2 Unscrew ball-valve from "T"**



**Step 3 Remove the threaded joiner**



**Step 4 Lay out the parts in order to assemble.**

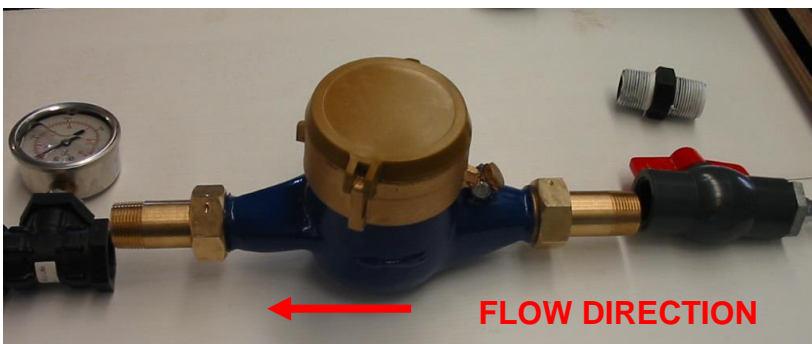

**Step 5** Use thread tape on threaded ends and assemble firmly.

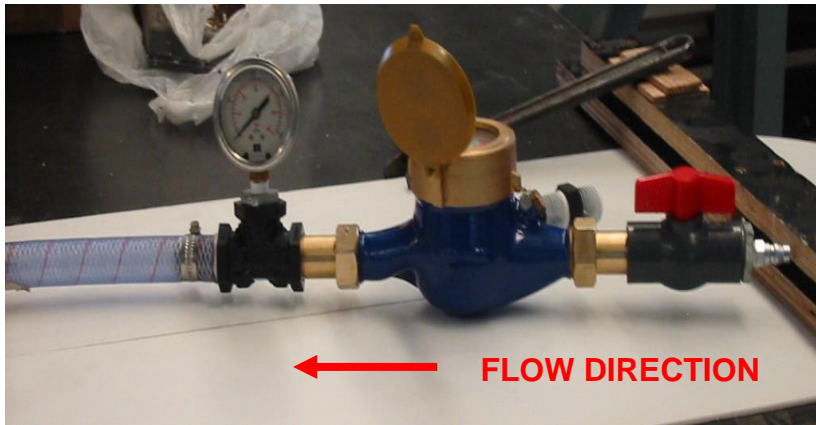

**Step 6** How to read



Flat slab with no thickenings can be done at 450mm spacing. Altis material costs under \$7 per metre<sup>2</sup>.

Engineered slab with thickenings can be done at 300mm spacings. Altis material costs under \$9 per metre<sup>2</sup>.

### PLEASE NOTE:

- Each system can only be for 100m<sup>2</sup>
- Pump capacity is required to be
 

7300 litres / hr	300 spacing.
4200 litres / hr	450 spacing.
- Calculate on 5 litres per m<sup>2</sup> for chemical

### APPROXIMATE CALCULATIONS

Based on 100m<sup>2</sup>

Labour calculated at approximately \$100/ hr

#### Per m<sup>2</sup>

Altis materials under \$7

Chemical calculated on FMC Bifenthrin Due @ 5L-m<sup>2</sup>

1g/l = \$1.00

Labour (10 mins \$17.00 - per m<sup>2</sup>)

**Total Approx \$25.00 m<sup>2</sup> + GST**

#### Per m<sup>2</sup> engineered slab

Altis materials under \$9

Chemical calculated on FMC Bifenthrin Duo @ 5L-m<sup>2</sup>

1g/l = \$1.00

Labour (12 mins \$20 – per m<sup>2</sup>)

**Total Approx \$30.00m<sup>2</sup> + GST**

**Refer to members costing schedule to calculate individual jobs.**

***Chemical costs relate to South of the Tropic of Capricorn.***



**150mm Sheet & Tape Perforated**  
**PRODUCT CODE 00004**

- Install at a depth 0-100mm using the 150mm perforated in the horizontal plan
- Capped with concrete or 50mm of soil.
- This will form a treatment area 150mm wide and to a depth of 100mm.
- Perforated plastic is always at the bottom and dripper line on the top so that emitters are facing downwards

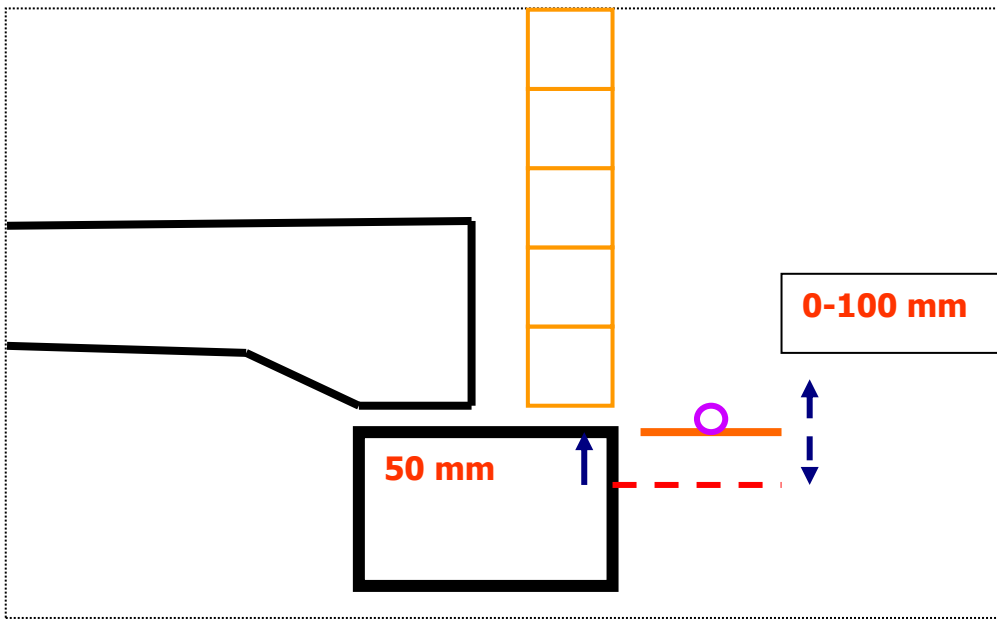

[www.altis.net.au](http://www.altis.net.au)

**T: 07 3349 9274 | F: 07 3849 7980 | E: [info@altis.net.au](mailto:info@altis.net.au) | PO Box 961 Sunnbank Q**



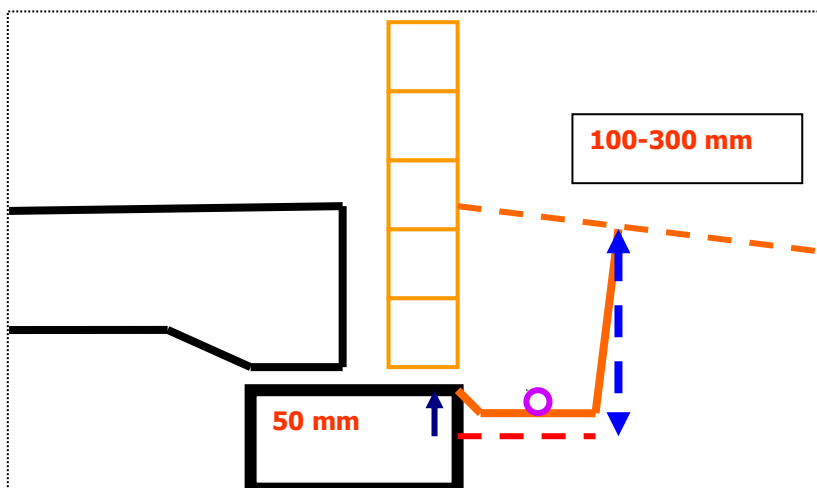

**300mm Sheet & Tape Unperforated**  
**PRODUCT CODE 00005**

- Install at a depth 100-300mm using the 300mm unperforated as a dam wall
- The feeder line can be at the base if the sheet can cover the full trench or at the top being 75mm below the finished soil level.
- This will form a treatment area 150mm wide and to a depth of 300mm.
- Perforated plastic is always at the bottom and dripper line on the top so that emitters are facing downwards

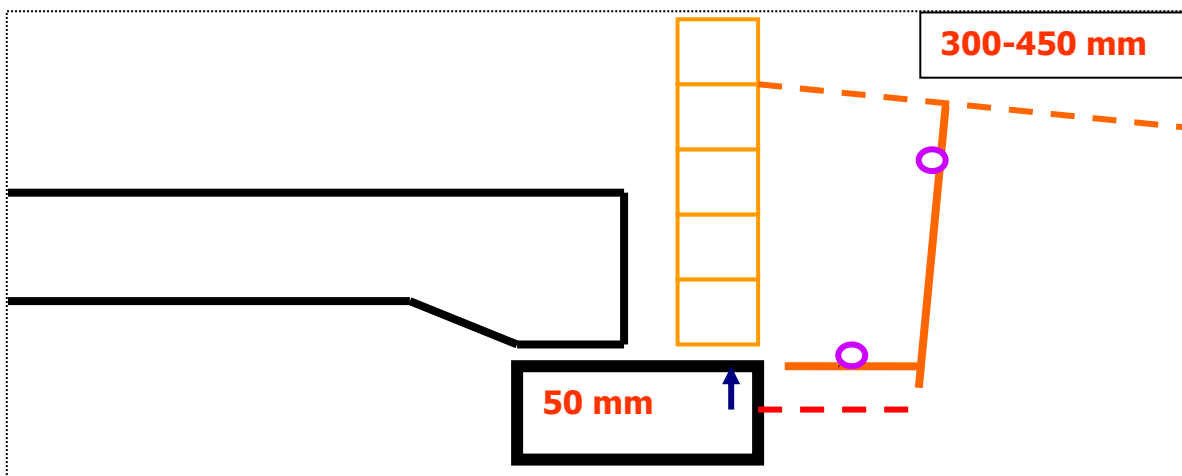

**150mm Sheet & Tape Perforated & 300mm Sheet & Tape Unperforated**  
**PRODUCT CODE 00004 & PRODUCT CODE 00005**

- At a depth 300-450mm, use the 150mm perforated in the horizontal plan at the top of the footing and the 300mm unperforated as a dam wall
- The feeder line will be at the top being 75mm below the finished soil level.
- This will form a treatment area 150mm wide and to a depth of 450mm.
- Perforated plastic is always at the bottom and dripper line on the top so that emitters are facing downwards

[www.altis.net.au](http://www.altis.net.au)
**T: 07 3349 9274 | F: 07 3849 7980 | E: info@altis.net.au | PO Box 961 Sunnbank Q**



**600mm Sheet & Tape Perforated**  
**PRODUCT CODE 00003**

- This product is suitable to form the horizontal barrier of the internal perimeter of slab and cover service penetrations for slab on ground construction.
- This is a 600mm wide perforated plastic sheet, fitted with 2 (two) runs of the emitter pipe fixed to the sheet. Each run of emitter pipe is spaced 300mm apart with each run 150mm in from the outer edge.
- Each run will overlap by 25 to 50mm and this overlap is tape sealed using Waterproof Adhesive tape 50mm wide.
- Each run of the Emitter pipe is fitted to the 25 mm diameter delivery manifold connected to the 25mm delivery (lead in ) pipe to the outside of the slab area. The opposite end of each run of the emitter pipe will be sealed using the 11END -10 end stop.
- This installation **MUST** be completely covered by polythene waterproof membrane before the steel reinforcing is placed prior to concrete pour.



[www.altis.net.a](http://www.altis.net.a)

**T: 07 3349 9274 | F: 07 3849 7980 | E: info@altis.net.au | PO Box 961 Sunnbank Q**



### 300mm Sheet & Tape Perforated PRODUCT CODE 00053

- Suitable to form the horizontal barrier of the internal perimeter of slab and the lead up to service and /or post penetrations for slab on ground construction. "Note all service penetrations must be covered by a minimum area of 600mm x 600mm as per slab penetration method.
- This is a 300mm wide perforated plastic sheet, fitted with 1 (one) run of the emitter pipe fixed to the sheet. This run of emitter pipe is centered with this run 150mm in from the outer edge.
- The Pre Assembled Economy 300 under slab sheet and tape product, is simply rolled out in a run around the internal perimeter of the complete area on the under slab
- Perforated plastic is always at the bottom and dripper line on the top so that emitters are facing downwards.

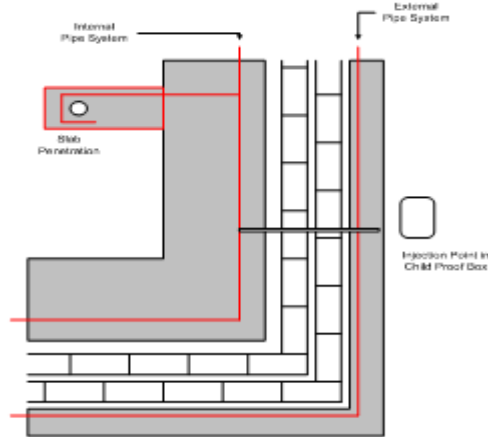

[www.altis.net.au](http://www.altis.net.au)

**T: 07 3349 9274 | F: 07 3849 7980 | E: info@altis.net.au | PO Box 961 Sunnbank Q**

**2 Metre Wide x 50m Perforated Plastic & Dripper Line**  
**PRODUCT CODE 00000 & PRODUCT CODE 00002**

- Flat slab with no thickenings manifold can be done at 450mm spacing.
- Engineered slab with thickenings manifold (must) be done at 300mm spacings.
- Each system can only be for 100m<sup>2</sup>
- Pump capacity is required to be
  - 7300 litres / hr 300 spacing.
  - 4200 litres / hr 450 spacing.
- Calculate on 5 litres per m<sup>2</sup> for chemical
- Perforated plastic is always at the bottom and dripper line on the top so that emitters are facing downwards

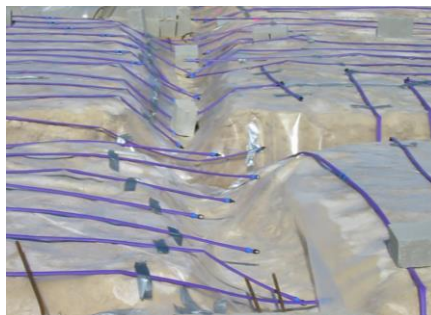
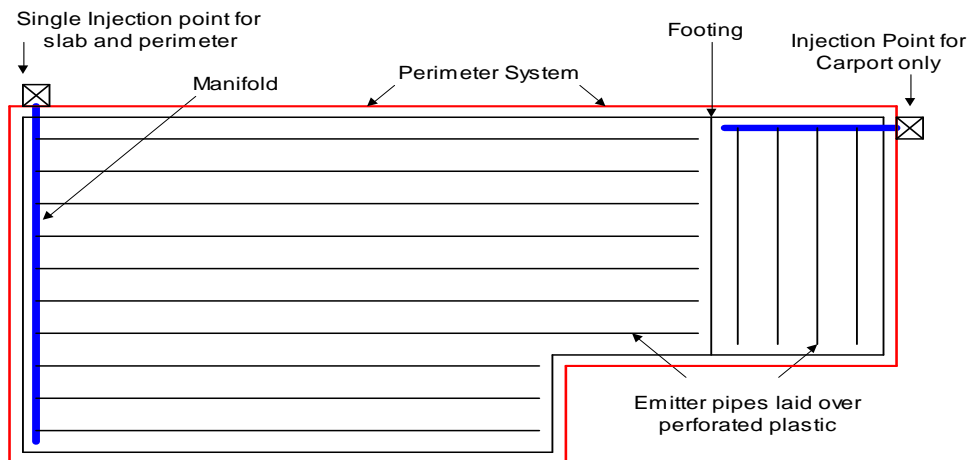
**T: 07 3349 9274 | F: 07 3849 7980 | E: info@altis.net.au | PO Box 961 Sunnbank Q**

Termidor® now has a new label which now includes the use of the Altis System.

“Reticulation Systems: Pre and Post-construction (Altis perimeter systems)”

**CRITICAL COMMENTS:** The system must be installed according to the manufacturer’s specifications and be capable of distributing the Termiticide emulsion according to this Termidor label.

**Altis Application Rates**

For all profiles the treatment rate is as per the label at a rate of 100 L per cubic meter of soil or for horizontal surfaces 5 L per square metre.

**Calculation Examples**

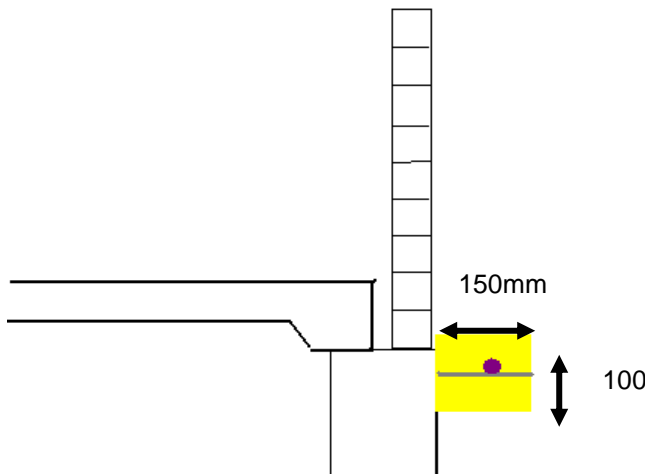

Minimum Treated zone is 150mm wide X 100mm deep

**Mathematical Calculation:**  
 $(0.15 \times 0.1) \times 100 = 1.5L/M$

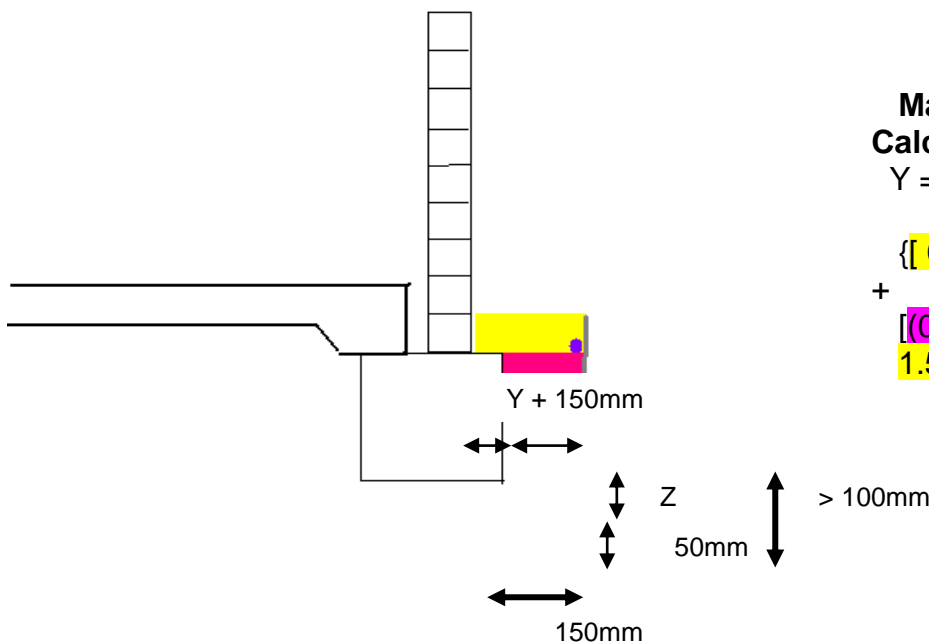

**Mathematical Calculation:**

Y = 50mm Z = 75mm

$$\{ [ 0.05 + 0.15 ] \times 0.75 \} \times 100$$

+

$$[ (0.15 \times 0.05) \times 100 ] =$$

$$1.5L + 0.75L = 2.25L/ M$$

**Wide extending footings**

**Mathematical Calculation:**

Y = 100mm. Z = 100mm  
 $\{[(0.1+0.15) \times 0.1] \times 100\} +$   
 $[(0.15 \times 0.05) \times 100] =$   
 $2.5 \text{ L} + 0.75 \text{ L} = 3.25 \text{ L/M}$

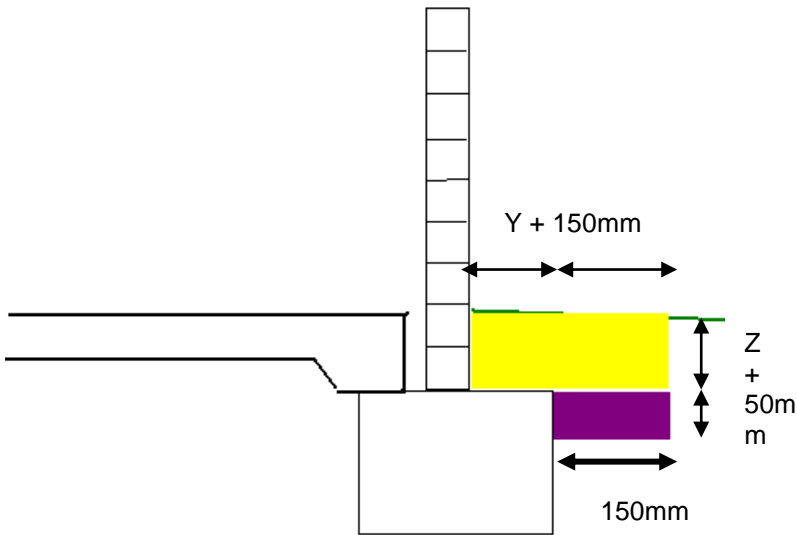

All or any variation of dimension needs to be re-calculated on the basis of applying 100L of prepared spray per cubic meter of soil.

**Approved Products for use in Altis Technically Advanced Anti-Termite System**

Manufacturer	Product Provided
Bayer	Premise 200SC
Syngenta	Altriset
Ensystem	Maxthor 100
Ensystem	Ultrathor Prothor 200SC
FMC	Biflex Aquamax
FMC	Biflex Ultra
David Gray	David Gray Bifenthrin Aqua
David Gray	David Gray Bifenthrin EC
Sherwood Chemicals	Fipforce Aqua
Sherwood Chemicals	Imilforce 200SC
Sherwood Chemicals	Biforce 100SC
Sherwood Chemicals	Biforce 200SC
Sherwood Chemicals	Ultraforce Aqua

Generic termiticides may be used on approval by Altis Pty Ltd.

For further information and assistance with calculations please contact the technical support at Altis by emailing [info@altis.net.au](mailto:info@altis.net.au) or by phone on 07 33499274.

**20 mm moulded manifold**

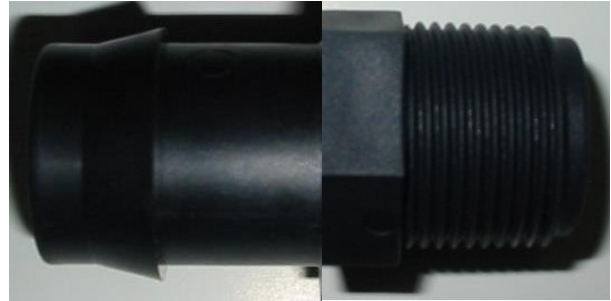
**take off end  
#00100**

**20/25mm director  
#00106**

When using the Moulded Manifold and having to position your pump-up point a distance away you can simple marry the two types of pipe fittings together by using a 20 mm male threaded / 25 mm barb end known as **20/25mm director** part number **#00106**

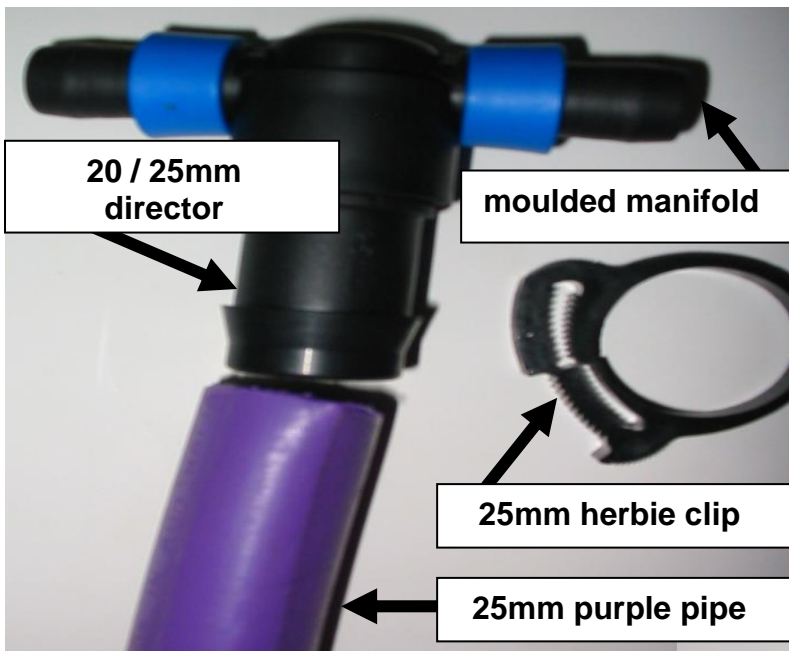
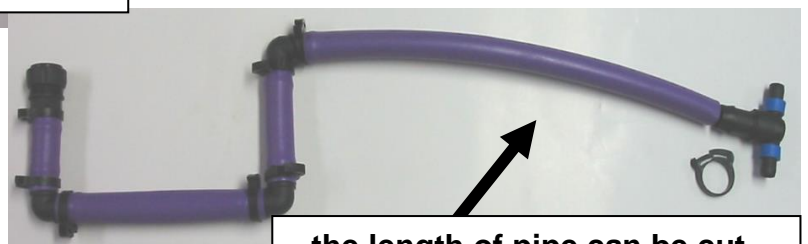
The Director screws into the Moulded manifold and the Standard 25mm purple pipe is attached and fastened using a Herbie clip.

**20 / 25mm  
director**
**moulded manifold**
**25mm herbie clip**
**25mm purple pipe**

**the length of pipe can be cut  
to suit each installation**



The use of a foaming agent in the Altis range of systems can help to achieve the correct label rate of application in areas where Subsidence is known or suspected.

### WHEN CALCULATING THE APPLICATION RATES:

Apply the following advised methodology:

Calculate the required volume:

1. Using the formula 100 L per m<sup>3</sup> of soil.  
(50m x 0.15x 0.10 x100L = 75 L)
2. Apply 70 % of the volume as normal mix ( 52.5L )
3. To the balance (22.5L) add the foaming agent as per the Manufacture's recommended rate for WET foam.  
( expansion ratio 5:1)
4. Apply the foaming mix with compressed air through the foaming RCPU.

The end result will be the correct GRAMS per CUBIC METRE OF SOIL as per the Termiticide label.



**Concrete Sub-Slab Foaming Rate:** 30 - 80 ml Termitafoam® to 5 litre water/pesticide solution. "Wet" foam is desired for sub-slab applications to adequately saturate the soil.

The foam consistency depends on the amount of foaming agent you add and more importantly the volume of air. It is all trial and error depending on the job. So it is best to start off at low volumes for both the foaming agent and the air. Test foam into a mixing jug until you get a stiff wet foam that will expand around 5 times its volume. This is easy to check:

1. Inject the mix **WITHOUT** air into the jug for 5 seconds, record the volume recovered.
2. Repeat the injection for 5 seconds **WITH** the air and record the volume recovered.
3. Divide volume 2 by volume 1 The answer should be around 5

Use good quality clean water to dilute the concentrate, avoid using hard water. On hot days increase the rate of concentrate up to double strength.

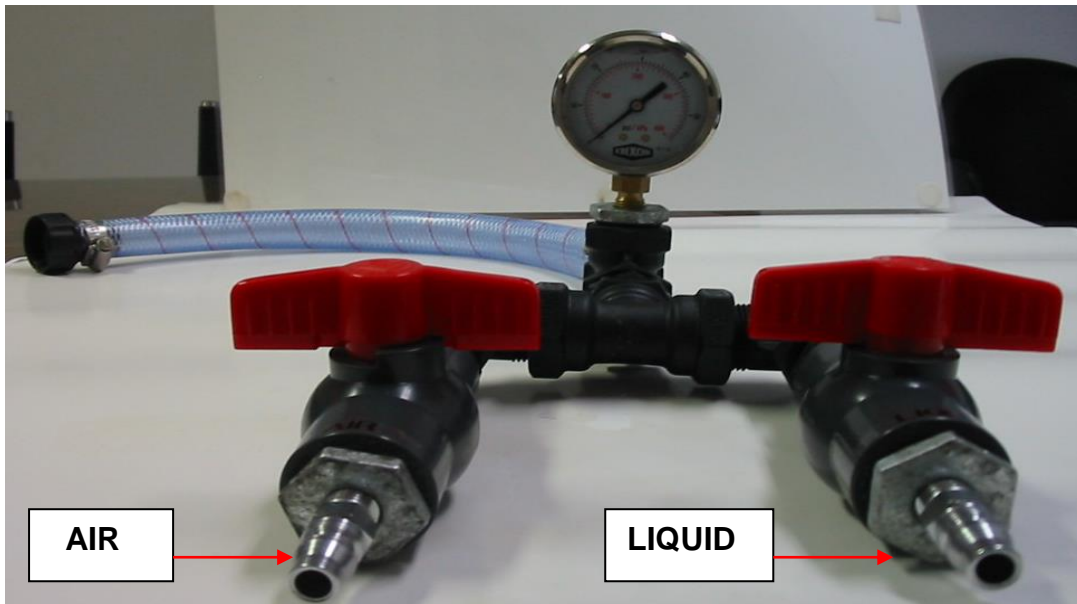

**RATES TAKEN FROM THE PREMISE and TERMIDOR LABEL AS BELOW**

Foam carriers may be useful in ensuring that a more even distribution is achieved. However it is important that the foam application be calibrated to ensure that the rate of Premise formulation does not fall below 12.5 mL of Premise 200 SC / m<sup>2</sup> and the rate of Termidor formulation does not fall below 30mL of Termidor / m<sup>2</sup>.

**Mixing table to prepare foam to treat 1 m<sup>2</sup>**

Premise 200 SC (mL)*	Litres of water	Foam expansion ratio	Volume of finished foam/m <sup>2</sup>	Foam consistency
12.5	5	1:1 (i.e. not foamed)	5 L	standard solution
12.5	2.5	5:1	12.5 L	wet foam
12.5	5	5:1	25 L	↑
12.5	2.5	10:1	25 L	
12.5	5	10:1	50 L	
12.5	2.5	20:1	50 L	↓
12.5	5	20:1	100 L	very dry foam

\*Add the manufacturer's recommended quantity of foam agent to the Premise solution

|

TERMIDOR Mix Rate	Litres of prepared TERMIDOR spray	Foam Expansion Ratio	Volume of finished foam required/m <sup>2</sup>
600mL/100litres of water plus recommended quantity of foaming agent	5	5:1	25L
	10 (under concrete)	5:1	50L
	5	10:1	50L
	10 (under concrete)	10:1	100L
	5	25:1	125L
	10 (under concrete)	25:1	250L

The use of a foaming agent in the Altis range of systems can help to achieve the correct label rate of application in areas where Subsidence is known or suspected. This is how to convert your existing RCPU to suit the use of foam.

You need your RCPU and the foam conversion kit.



1. Unscrew the ball valve including the male threaded joiner.



2. Assemble using a male-male threaded joiner and a female Tee.



3. Add two (2) male / female threaded 90° joiners.



- 4. Assemble and attach the two (2) Ball valves and turn the pressure gauge to face the ball valves, check all fittings as your RCPU foamer is complete.



**THIS IS TO BE USED AS “APPENDIX SOIL” TO THE ALTIS INSTALLERS MANUAL**

The quality of the soil or sand matrix used to create a Termiticide barrier is more important than the selection of the product you will be applying.

The Altis Technical Assessments 145 states:

“The sand is nominally 50mm in depth is clean and has a grade within the following specification, 95-100% passing 6.7mm and 0-10% passing 75um sieves.”

The Altis Technical Assessments 222 states:

“The sand is packing sand is clean and has a grade within the following specification, 95-100% passing 6.7mm and 0-10% passing 75um sieves.”

In both the sieve size comply with AS 1152-1993 ‘Specification for test sieves.’

**Guidance:**

All soil matrix must be clean of organic material, stone and building rubble, the matrix must be able to absorb not less than 2 l/m<sup>2</sup> for horizontal barriers, (Target: 5 l/m<sup>2</sup>) and not less than 40 l/m<sup>3</sup> for vertical barriers,(Target: 100 l/m<sup>3</sup>).

The volume of Termiticide to water will change in proportion to the rate of application to the soil.

Check your product label for the scale and mix rates.

Altis approved Termiticides:

**COMPLIANCE WITH THIS TECH NOTE IS A CONDITION OF THE ALTIS INSTALLER AGREEMENT AND IS A CONDITION OF THE ALTIS CODEMARK QUALITY SYSTEM.**

**IF YOU ARE UNSURE OF THE QUALITY OF YOUR LOCAL SOIL MATRIX CONTACT ALTIS FOR GUIDANCE.**

- Bayer - Premise 200SC
- Syngenta - Altriset
- Ensystem - Maxthor 100
- Ensystem - Ultrathor Prothor 200SC
- FMC - Biflex Aquamax
- FMC - Biflex Ultra
- David Gray - David Gray Bifenthrin Aqua
- David Gray - David Gray Bifenthrin EC
- Sherwood Chemicals - Fipforce Aqua
- Sherwood Chemicals - Imilforce 200SC
- Sherwood Chemicals - Biforce 100SC
- Sherwood Chemicals - Biforce 200SC

Sherwood Chemicals - Ultraforce Aqua

**THIS IS TO BE USED AS GUIDE TO ALTIS INSTALLERS**

Recently areas in Queensland, New South Wales and Victoria have been affected by heavy rain and flooding, we have had questions asked about how these weather events will effect the termite barrier system that have been installed.

This advice also applies to any area which has become inundated (flooded), even a localised event such as a blocked drain.

1. The approved Termiticide under normal weather events **WILL NOT RINSE** out of the soil.
2. Termiticide **WILL NOT** transfer from treated soil to introduced soil (silting after flooding).
3. Flooding **MAY WASH AWAY** treated soil leaving gaps or holes in treated zones.
4. Areas under concrete pathways and driveways that have been lifted by or undermined by flooding waters **WILL HAVE THEIR SERVICEABLE LIFE GREATLY REDUCED.**
5. Areas under paving stones that have been lifted by or undermined by flooding waters **WILL HAVE THEIR SERVICEABLE LIFE GREATLY REDUCED.**

As the actual protection period is dependent on the climate, soil conditions, the rate of Termiticide used and prevailing termite pressure. The above points must be seriously considered when evaluating the need for re-treatment.

**Minimum advice is to increase the frequency of inspections.**

The quality of the soil or sand matrix used to create a Termiticide barrier is more important than the selection of the product you will be applying.

**Guidance:**

All soil matrix must be clean of organic material, stone and building rubble, the matrix must be able to absorb not less than 2 l/m<sup>2</sup> for horizontal barriers, (Target: 5 l/m<sup>2</sup>) and not less than 40 l/m<sup>3</sup> for vertical barriers,(Target: 100 l/m<sup>3</sup>).

The volume of Termiticide to water will change in proportion to the rate of application to the soil. Check your product label for the scale and mix rates.

**Altis approved Termiticide:**

**This is also an ideal time to upgrade from a soil only to an Altis rechargeable system as the benefit of the rechargeable system has great saving after weather events such as flooding.**

Bayer - Premise 200SC  
 Syngenta - Altriset  
 Ensystem - Maxthor 100  
 Ensystem - Ultrathor Prothor 200SC  
 FMC - Biflex Aquamax  
 FMC - Biflex Ultra  
 David Gray - David Gray Bifenthrin Aqua  
 David Gray - David Gray Bifenthrin EC  
 Sherwood Chemicals - Fipforce Aqua

Sherwood Chemicals - Ultraforce Aqua  
 Sherwood Chemicals - Imilforce 200SC  
 Sherwood Chemicals - Biforce 100SC  
 Sherwood Chemicals - Biforce 200SC

**THIS IS TO BE USED AS GUIDE TO ALTIS INSTALLERS**

**Step 1:** Know the depth of the hole that the pole or post is to be installed.

**Step 2:** Mark out the depth on the pole/post, and mark the 150mm spacings.

**Step 3:** Make a loop by feeding the Altis ribbon through the loop on the stop-end.

**Step 4:** Place this loop at the bottom of the pole/post and fix the stop-end with a galvanised nail or screw.

**NOTE: The delivery points MUST FACE THE POLE SURFACE. (White dot down)**

**Step 5:** Loop the Altis ribbon up the pole/post, following the 150mm spacings.

**Step 6:** Fit the moulded manifold in the Altis ribbon at the top marker.

**Step 7:** Cut a length of Altis ribbon so as to complete a full loop of the post/pole. Fit this to the moulded manifold at one end and fit a stop-end to the other.

**Step 8:** Pull the stop-end so that the ribbon on the pole/post is firmly held in place and fix this end to the pole/post with a galvanised nail or screw.

**Step 9:** Fit a screw in cap to the moulded manifold and nail the Altis warning plate to the pole/post above the filler point and above finished ground level.





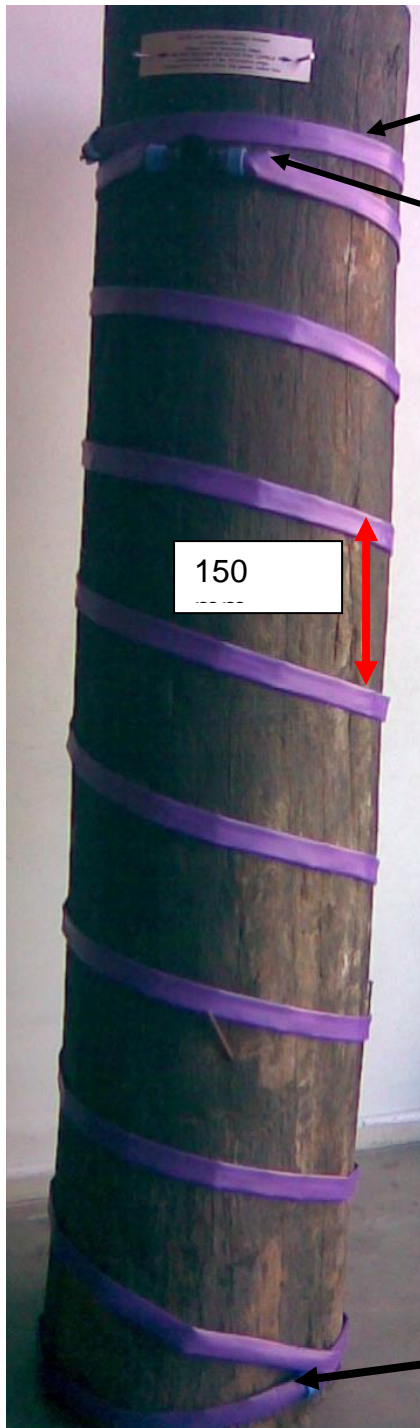

- Full loop at the top with stop end pinned to pole to keep ribbon tight and in-place.

- Use the moulded manifold

- Each spiral loop is 150mm apart as it rises from the bottom full loop.

- Full loop at the bottom with the ribbon running through the stop-end loop and the stop end pinned to pole to keep ribbon tight and in-place.



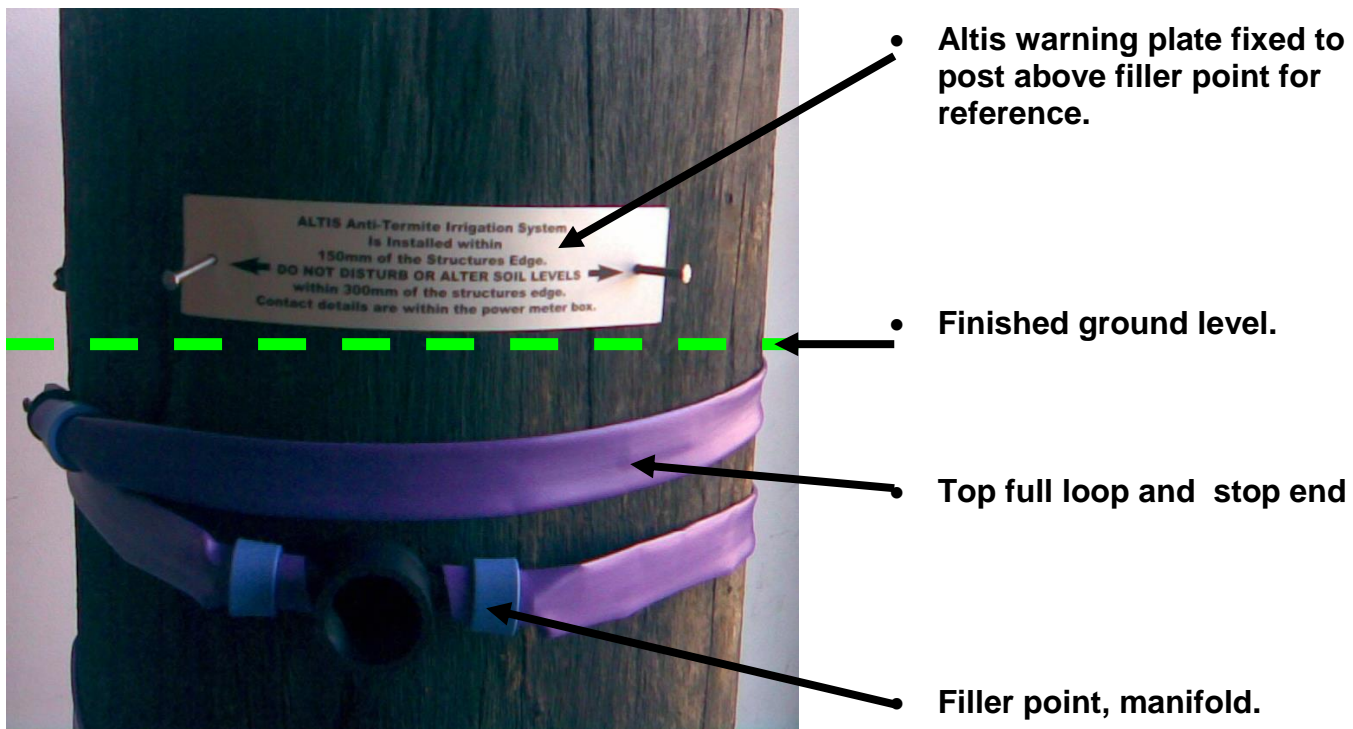

The quality of the soil or sand matrix used to create a Termiticide barrier is more important than the selection of the product you will be applying.

**Guidance:**

All soil matrix must be clean of organic material, stone and building rubble, the matrix must be able to absorb not less than 2 l/m<sup>2</sup> for horizontal barriers, (Target: 5 l/m<sup>2</sup>) and not less than 40 l/m<sup>3</sup> for vertical barriers,(Target: 100 l/m<sup>3</sup>).

The volume of Termiticide to water will change in proportion to the rate of application to the soil.

Check your product label for the scale and mix rates.

**Altis approved Termiticide:**

- |   |                                      |
|---|--------------------------------------|
| Bayer - Premise 200SC                   | Sherwood Chemicals - Ultraforce Aqua |
| Syngenta - Altriset                     | Sherwood Chemicals - Imilforce 200SC |
| Ensystem - Maxthor 100                  | Sherwood Chemicals - Biforce 100SC   |
| Ensystem - Ultrathor Prothor 200SC      | Sherwood Chemicals - Biforce 200SC   |
| FMC - Biflex Aquamax                    |                                      |
| FMC - Biflex Ultra                      |                                      |
| David Gray - David Gray Bifenthrin Aqua |                                      |
| David Gray - David Gray Bifenthrin EC   |                                      |
| Sherwood Chemicals - Fipforce Aqua      |                                      |

This is also an ideal time to upgrade from a soil only to an Altis rechargeable system as the benefit of the rechargeable system has great saving after weather events such as flooding.

## Altis Application Rates

For all profiles the treatment rate is as per the label at a rate of 100 L per cubic meter of soil or for horizontal surfaces 5 L per square metre.

## Calculation Examples:

You have a pole/post that has a diameter of 380mm and the treated zone is to be 150mm wide with the depth of the pole/post in the ground to be 2.4m.

To calculate the volume required use the following formula:

The volume of the pole/post: 'V' =  $\pi R^2 \times D$

Volume of the treated area: TV = V of post & barrier – V of post.

Volume of Termicide required:  $M^3 \times 100 \text{ L} = \text{Volume required.}$

EG: pole is 380mm wide and the depth will be 2.4m with a treated width of 150mm

There fore:

$$TV = [\pi \times (R \text{ of post} + \text{barrier width})^2 \times D] - [\pi \times R \text{ of post}^2 \times D]$$

$$[3.14 \times (0.19 + 0.15)^2 \times 2.4] - [3.14 \times 0.19^2 \times 2.4]$$

$$[3.14 \times 0.34^2 \times 2.4] - [3.14 \times 0.036 \times 2.4]$$

$$[3.14 \times 0.1156 \times 2.4] - [3.14 \times 0.036 \times 2.4]$$

$$[3.14 \times 0.277] - [3.14 \times 0.0864]$$

$$0.8697 - 0.2713$$

$$0.5984 \text{ M}^3$$

Volume of Termicide required:  $M^3 \times 100 \text{ L} = \text{Volume required.}$

$$0.5984 \text{ M}^3 \times 100 = 59.84 \text{ L}$$

**THIS IS TO BE USED AS GUIDE TO THE USE OF THE SCREW FITTINGS TO BUILD EXTERNAL MANIFOLDS THAT IS COST EFFECTIVE.**

The range of screw together fittings has been available for over twelve month's and there are many benefits to using them for your external pump-up points.

These fittings remove the use of glue and the use of the purple 25mm pipe and ratchet (Herbie) clips. This allowing you to make manifold using fewer parts and at a lower cost and still having many options that are very easy to assemble.

**Options:**

The base can be used as a single sided or double sided manifold.

By using a mix of the parts you can make up a manifold to suit the finish of the system and the security of the pump-up point.

**INLINE 25mm male end**

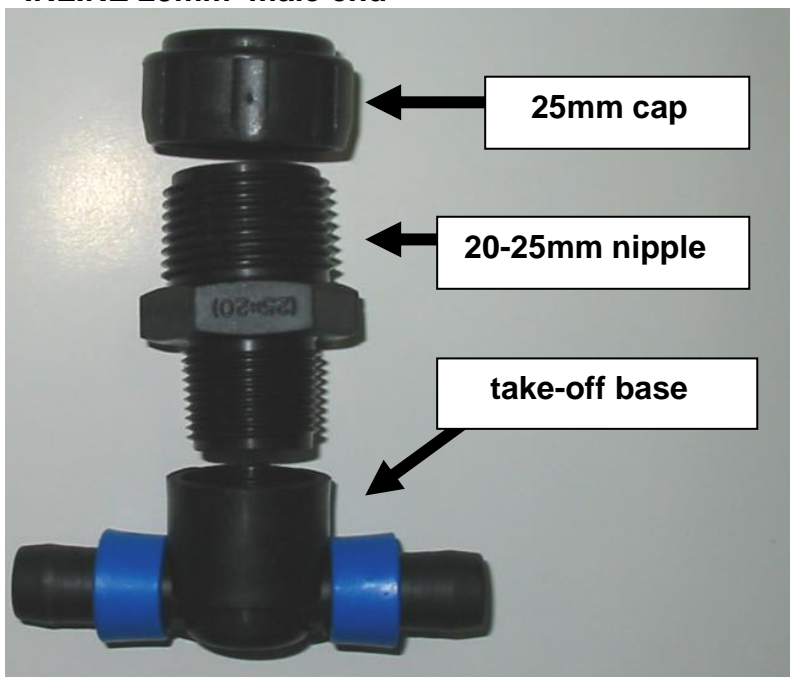

**OFF LINE MANIFOLD 20mm male end**

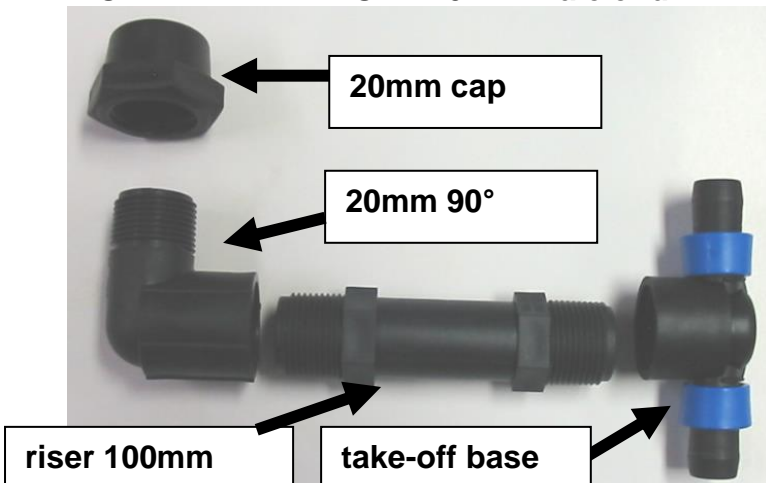

Off line double sided manifold, places the filler point outside the treated zone. This reduces the risk of disturbance to the treated zone by others. This is the preferred installation method.

The off line manifold can be reversed. This is useful for when the take off is deeper than the filler point or when using the 300mm dam wall external barrier.



You can place the pathway trap over the complete system or off to the side out of the treated zone.

Where you only need the manifold to be single sided you simple use a STOP END and a section of the blank black 17mm line to stop end the second take off point.

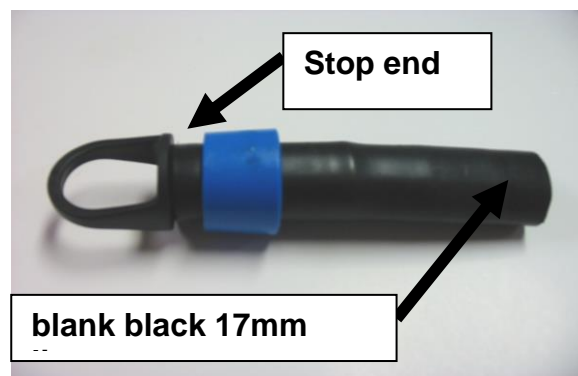

### S. Screw lock in concrete with tiled, colored or painted finish



This unit is complete and has been developed to be installed into concrete patios, pathways or driveways. The size and depth suits concrete up to a depth of 100mm. This unit allows for the Altis delivery ribbon to be covered by soil or sand and the access to pump-up is via a sealed chamber.

**NO CHEMICAL EXPOSURE AND SIMPLE READY TO USE INSTALLATION.**

If required security screws are available to replace the standard Philip head screws.



**HERE ARE SOME HELPFUL HINTS AND SOME OTHER TIPS FOR USING YOUR FLEXSCOPE.**

1. If your flexscope turns itself off after only 15 to 20 minutes or so of use, you may not be able to turn it back on. In this case, use the end of one of the head cleaners to reset the flexscope. You can do this by poking the head cleaner into the reset button hole that is located on the back of the unit. You should now be able to turn your flexscope back on. If this reoccurs you will need to contact us as soon as possible.



2. Always charge your scope after you have used it. This will ensure the battery does not run out the next time you need to use it. Overnight charge should be done, not 1 hour here, 1 hour there.
3. When drilling a hole into a wall for your flexscope, please remember that the cable is 5.5mm & the hole you will need will need to be 6.5mm.



4. Do not use force to push the probe into any area. If necessary drill another hole and go around. This will prevent any damage occurring to the lens of the cable. If it has been damaged, you will not be covered under warranty & will be liable for the cost of replacement parts and repairs. Remember, the end of the probe is where the camera is located.

**Damaged cable from incorrect use.**

**This cable was probed into a mud nest and the glass covering the lens fell out.**

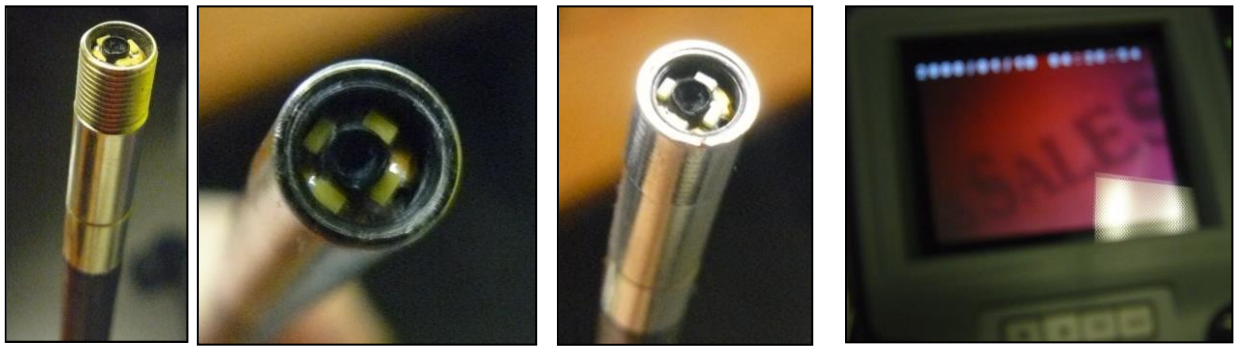

**Amazingly this camera still works, but the quality is poor. It cannot be repaired. A new cable is needed. Cables are expensive and cost \$550.00 to replace**

**Picture quality of the damaged camera.**

**How the cable & lens should look.**

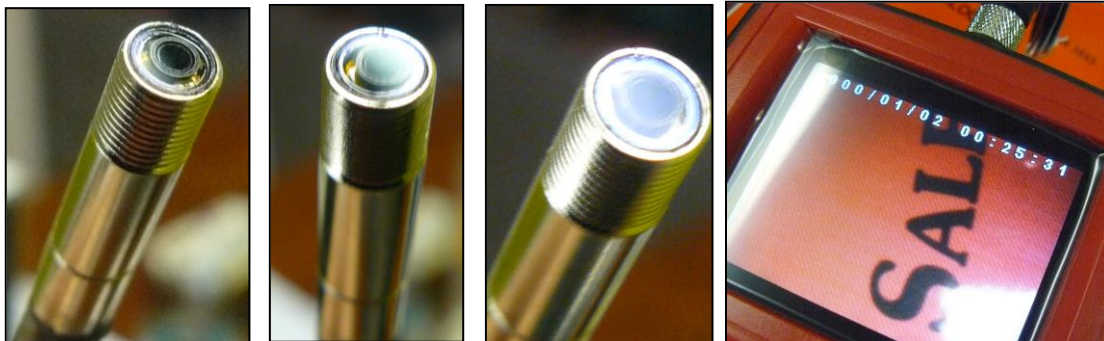

**How the picture quality should be.**

5. Please be careful when using the flexscope, it is a valuable piece of equipment that can assist in many areas. It must be treated with care.

As you know there are 4 different angles you can see when you are using the Flexscope.

The first one is the straight ahead shot and is the only one you get which shows actual vision through the lens.



**Straight Ahead Angle**



The other 3 attachments, 35°, 45° and 60° use mirrors to reflect the vision through the lens. Whenever you use any of these 3 angles you will not get a full picture of the object you are looking at. Approximately 30% of the picture will be a reflection of the side walls of the 35°, 45° or 60° extensions you are using.



**35°, 45° & 60° Angled Mirrors**

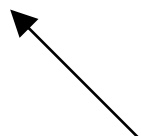

Remember that any Capital equipment purchases ie items valued \$1000 and over made between 30 December, 2008 and 30 June, 2009 attract a special concession. This special concession is 30% and is in addition to the normal depreciation allowance. The depreciation continues for the life of the items.



**IMPORTANT INFORMATION ABOUT YOUR FLEXSCOPE**

1. If you have not used your Flexscope for some time, or don't plan on using it for a while it is important that you continue to charge your flexscope for a full 24 hour period **at least once a month**.
2. When your Flexscope is left sitting stagnant for a long time the next time you go to use it, it may take 2-3 days to charge the battery rather than just having to charge it over night.
3. Following this simple instruction will make sure your Flexscope is always ready to go whenever you are.

If you have any questions or concerns regarding your Flexscope then please do not hesitate to contact us.

Please also remember if you have any interesting or unusual footage then send it to us with a description and we would love to use it for our newsletters!



## INTRODUCING THE NEW MULTI MANIFOLD SINGLE/ DOUBLE 150MM TAKE OFF 20054

We have developed a revised manifold that will replace most manifolds including external perimeter 150mm wide and 300mm dam wall as well as 300mm economy underslab.

The manifold is suitable to link the system to a pump up point for installations up to 100Lm. It is supplied as a pre-assembled single/ double manifold kit complete with 4 X 25mm herbie clips, 1 X pump up tag and 2 X meter box stickers all in a bag.

These manifolds can be purchased from your Distributor.



## INTRODUCING THE NEW BARB PUNCH & INSERT TOOL

We are introducing a New Barb Punch & Insert Tool (Code 20055) which replaces the existing Barb Insert Tool and the Purple Manifold Pipe Cutter Tool (Code 20018).

The new tool is one tool which replaces both the previous units. It is used to punch holes in the 25mm purple manifold pipe (Code 20013) and to insert the take off barbs.

We do not envisage this tool as being a high usage item as it would normally only be used where complex manifolds are required, more particularly in full underslab projects.



[www.altis.net.au](http://www.altis.net.au)

T: 07 3349 9274 | F: 07 3849 7980 | E: [info@altis.net.au](mailto:info@altis.net.au) | PO Box 961 Sunnybank Q  
4100

## MANIFOLDS & LOW USE ITEMS

Since the introduction of the Multi Manifold we have found that it meets virtually all the current Manifold requirements. The only exceptions being the 600mm perimeter underslab manifold and the tailor made manifolds required for full underslab.

For that reason and in order to further simplify the system and to reduce the inventory holdings of the Distributors we are withdrawing the items formerly listed on the System Fittings & Photos List under the heading “Purple Manifold Fittings” and consisting of part numbers 20007 to 20012 inclusive and part number 20016. This is to take effect immediately.

The revised Parts Description provides the up to date list and removes other items which are low usage.

There might be the odd occasion where a “tailor made” Manifold might be required. If you see the need for this you need to contact us so that we can assist.

Yours faithfully,

**Grant Currie**  
Director

## WEST COAST SYSTEM FITTINGS & PHOTOS LIST WITHDRAWN

Dear WA Installer,

Altis has had 2 different parts lists. One for the East Coast and another for the West Coast.

Effectively immediately the West Coast System Fittings & Photos list will be withdrawn giving us one list for all States. A copy of the F20. System Fittings & Photos List is attached for your information. This information is also available on our website [www.altis.net.au](http://www.altis.net.au)

The biggest change is the change in manifolds. We will no longer use Class 18 PVC pipe or any of the glued fittings. Manifolds will be sold as complete units. There will be 2 available these are:

- **Part # 20053** – Purple Manifold Complete double 600mm take off.

This manifold is used for underslab work for the 600mm wide perforated sheet with 2 runs of dripper line (Part # 00003).

And

- **Part # 20054** – Purple Multi Manifold Single/Double.

This manifold can be used for External Perimeter jobs as well as for 300mm underslab ie for parts # 00053, 00004 & 00005.

There will be some unusual jobs which might require a custom made manifold. You would need to consult with Grant Currie in these cases and we will arrange to produce what you need and talk you through the job.

If you have any queries please contact our office on 07 3349 9274.

Regards,

**Belinda Ellis**  
**Administration Officer**  
**26 April 2012**

[www.altis.net.au](http://www.altis.net.au)

**T: 07 3349 9274 | F: 07 3849 7980 | E: [info@altis.net.au](mailto:info@altis.net.au) | PO Box 961 Sunnybank Q**

4100



## TECH NOTE

RE-ISSUE: 32  
DATE: 04/04/2017  
REF: ALTIS PERFORATED  
AND UNPERFORATED  
PLASTIC SHEET AND USE OF  
ANY COMPONENTS NOT  
SUPPLIED BY ALTIS

### **THIS IS TO BE USED AS GUIDE TO ALTIS INSTALLERS**

It has come to our attention that some installations of the Altis System are being carried out by using the "emitter pipe" by itself i.e. the perforated plastic sheet has been removed or in the case of the 300mm "dam wall" the unperforated sheet.

This practice is unacceptable. The complete removal of the plastic sheet is contrary to the design of the Altis System and to the CodeMark approval of the product. Removal is not supported by Altis Pty Ltd. if you do adopt this procedure i.e. cutting the perforated plastic sheet you must note what you have done on your Installation Certificate. It is also suggested that you take photographs of the particular situation.

There is still a requirement to cover the system/s with soil.

Similarly use of any components available from but not supplied by Altis will result in a withdrawal of Altis support.

If you have any questions or wish to make suggestions to improve the Altis System, then please contact us on [info@altis.net.au](mailto:info@altis.net.au) or (07) 3349 9274

Grant Currie  
Director

[www.altis.net.au](http://www.altis.net.au)

T: 07 3349 9274 | F: 07 3849 7980 | E: [info@altis.net.au](mailto:info@altis.net.au) | PO Box 961 Sunnbank Q



**ALTIS ACCREDITED INSTALLERS WORK METHOD STATEMENT**  
**In accordance with Altis Anti-Termite System and Australian Standards AS**  
**3660.1 – 2000**  
**New Construction**

**FOR THE ACTIVITY OF THE INSTALLATION AND CHARGING OF:**

- ALTIS FULL UNDERSLAB SYSTEM**
  
- ALTIS STANDARD INTERNAL & PENETRATION SYSTEM**
  
- ALTIS EXTERNAL PERIMETER SYSTEM**
  
- ALTIS VERTICAL SOIL MATRIX SYSTEM**

This Work Method Statement must be given to the Principal Contractor before work starts.

The Principal Contractor must sign and date this Work Method Statement.

**Subcontractor's details:**

Name:		
ABN #		
Address:		
Telephone #		Fax #
E-mail address:		
Person to monitor and review control measures.		
Subcontractor's signature:		Date
Principal Contractor or Representative Signature:		Date

# ALTIS ACCREDITED INSTALLERS WORK METHOD STATEMENT

Project details:

Principal Contractor	
Site Address	

## PPE Requirements:

- Respirator, 
  hard hat, 
  safety goggles, 
  steel capped boots, 
  ear plugs, 
  elbow length gloves, 
  others:

---



---



---



---

## Special requirements:

- warning signs, 
  tenant, 
  general public, 
  others:

---



---



---



---

Step #	Sequence of basic job steps	Potential hazards	Control measures
1	Arrange access with site manager; date & time		
2	Arrive promptly, park safely & conveniently for work to begin		
3	Put on relevant PPE		



4	Select appropriate Altis component and installation equipment according to Altis installation manual		
5	Access building site to begin installation		
6	Effect installation and clean up site		
7	Advise/report/record		
8	Complete company records		
9	Select appropriate chemical & mix according to label		
10	Access building site to begin treatment (system charging)		
12	Effect treatment (system charging)		
13	Advise/report/record (system charging)		
14	Complete company records (system charging)		

Technician Name:

\_\_\_\_\_

PMT Lic No: \_\_\_\_\_

Comments:

\_\_\_\_\_